

FAGOR 8037 CNC

Ordering Handbook.

Ref. 1410



NOMENCLATOR

CNC 8037-T-40-ETH

M : Milling machines & Centers
T : Lathes and Turning Centers
TC : Conversational model for Lathes

16 : 16 Digital Inputs / 8 Digital Outputs
40 : 40 Digital Inputs / 24 Digital Outputs
56 : 56 Digital Inputs / 32 Digital Outputs

ETH : Ethernet communication
CAN : CAN interface for drive system
CAN-RIO : CAN interface for drive system &
 CAN interface for Remote I/O's

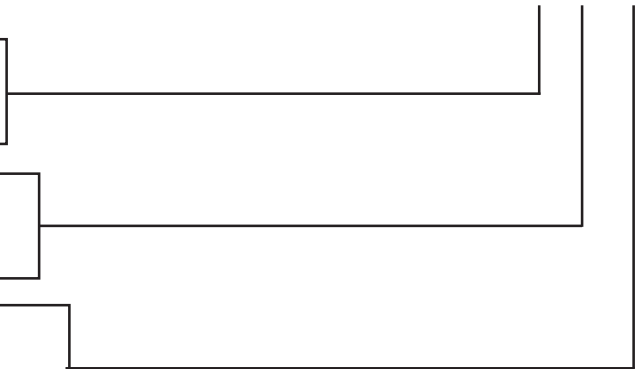

MODELS



Milling machines & Centers (M)

83370010 CNC 8037-M-16-CAN-RIO (*)

83370020 CNC 8037-M-40

83370021 CNC 8037-M-40-ETH

83370022 CNC 8037-M-40-CAN

83370023 CNC 8037-M-40-CAN-RIO

83370050 CNC 8037-M-56 (*)

83370051 CNC 8037-M-56-ETH (*)

83370052 CNC 8037-M-56-CAN (*)



Lathes and Turning Centers (T)

83370011 CNC 8037-T-16-CAN-RIO (*)

83370030 CNC 8037-T-40

83370031 CNC 8037-T-40-ETH

83370032 CNC 8037-T-40-CAN

83370033 CNC 8037-T-40-CAN-RIO



Conversational model for Lathes (TC)

83370012 CNC 8037-TC-16-CAN-RIO (*)

83370040 CNC 8037-TC-40

83370041 CNC 8037-TC-40-ETH

83370042 CNC 8037-TC-40-CAN

83370043 CNC 8037-TC-40-CAN-RIO

(*) Sale restricted. Consult with Fagor

CONFIGURATIONS

CNC 8037	
Models	
Milling	M
Lathe	T, TC
Axes and Spindles	
Lathe axes	2
Mill axes	3
Spindles	1
Communication buses	
RS 232 up to 115.200 Bd	Sí
DNC Communications	Sí
USB	Sí
Ethernet	Option
Analog	Sí
Digital CAN for drivers	Option
Bus CAN for remote modules	Option
System architecture	
Monitor	LCD 7.5" Color
Feedback inputs for axes & spindle	4 TTL/1Vpp
Feedback inputs for handwheels	2 TTL
Analog outputs (± 10 V)	4 for axes & spindle
Probe inputs, 5V (0,25mA) or 24V (0.30 mA)	2
Local digital inputs and outputs (100 mA)	16 DI / 8 DO 40 DI / 24 DO 56 DI / 32 DO
CAN board for connection to remote modules	Option
CAN board for digital connection with the drives	Option
RAM memory	
RAM Memory	1 MB
KEYCF flash memory	512 MB
Axis adjustment	
Look Ahead	75 blocks
Jerk control	Sí
AC Forward	Sí
Oscilloscope function (setup assistance)	Sí
Circularity test (setup assistance)	Sí
Processing time	
Block processing time	7 ms
Minimum position loop	4 ms
PLC cycle time (ms / 1,000 instructions)	3

SOFTWARE FEATURES.

	CNC 8037-M	CNC 8037-M-ETH	CNC 8037-M-CAN	CNC 8037-M-CAN-RIO	CNC 8037-T	CNC 8037-T-ETH	CNC 8037-T-CAN	CNC 8037-T-CAN-RIO	CNC 8037-TC	CNC 8037-TC-ETH	CNC 8037-TC-CAN	CNC 8037-TC-CAN-RIO
LCD	7.5"				7.5"				7.5"			
Block processing time	7 ms				7 ms				7 ms			
Loop time	4 ms				4 ms				4 ms			
Look ahead	75 blocks				75 blocks				75 blocks			
Number of axes	(3)	(3)	(3)	(3)	(2)	(2)	(2)	(2)	(2)	(2)	(2)	(2)
Save, Edit & Execute programs in KEYCF	(1)	(1)	(1)	(1)	(1)	(1)	(1)	(1)	(1)	(1)	(1)	(1)
Machining canned cycle	(1)	(1)	(1)	(1)	(1)	(1)	(1)	(1)	(1)	(1)	(1)	(1)
Ethernet	(-)	(1)	(1)	(1)	(-)	(1)	(1)	(1)	(-)	(1)	(1)	(1)
Roscado rigido // Rigid tapping	(1)	(1)	(1)	(1)	(1)	(1)	(1)	(1)	(1)	(1)	(1)	(1)
DNC (DNC Communications)	(1)	(1)	(1)	(1)	(1)	(1)	(1)	(1)	(1)	(1)	(1)	(1)
Compensación de radio // Tool radius compensation	(1)	(1)	(1)	(1)	(1)	(1)	(1)	(1)	(1)	(1)	(1)	(1)
Ayudas en puesta a punto // Setup assistance	(1)	(1)	(1)	(1)	(1)	(1)	(1)	(1)	(1)	(1)	(1)	(1)
Retroceso // Retracing	(1)	(1)	(1)	(1)	(-)	(-)	(-)	(-)	(-)	(-)	(-)	(-)
Editor de perfiles // Profile editor	(-)	(-)	(-)	(-)	(-)	(-)	(-)	(-)	(1)	(1)	(1)	(1)
Sistema regulación CAN // CAN driver system	(-)	(-)	(1)	(1)	(-)	(-)	(1)	(1)	(-)	(-)	(1)	(1)
Módulos Remotos I/O // Remote I/O modules	(-)	(-)	(-)	(1)	(-)	(-)	(-)	(1)	(-)	(-)	(-)	(1)
Herramienta motorizada // Live tool	(-)	(-)	(-)	(-)	(-)	(-)	(-)	(-)	(-)	(-)	(-)	(-)
Software conversacional TC	(-)	(-)	(-)	(-)	(-)	(-)	(-)	(-)	(1)	(1)	(1)	(1)
(-)	No disponible (Not available)											
(1)	Prestación estándar (Standard feature)											

REMOTE I/O MODULES

RIO5 series. Remote modules with CANopen protocol

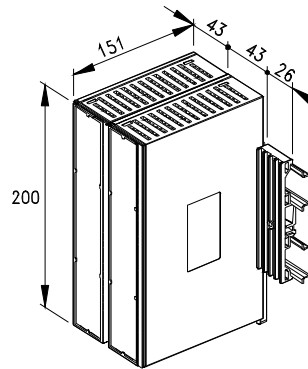

Power Supply & 24I/16O	RIO5-PS-24I/16O	83070015
Power Supply & 2 PT100 & 4Ai/4AO	RIO5-PS-2PT100/4AI/4AO	83070018
Expansion module 24I/16O	RIO5-24I/16O EXP MOD	83070016
Expansion module 48I/32O	RIO5-48I/32O EXP MOD	83070017



RIO5-PS-24I/16O 83070015

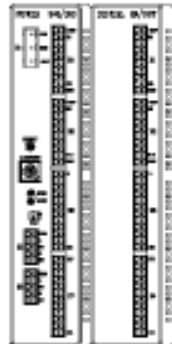

RIO5-PS-24I/16O 83070015
RIO5-24I/16O EXP MOD 83070016



RIO5-PS-24I/16O 83070015
RIO5-48I/32O EXP MOD 83070017

RIOW series. Remote modules with CANopen protocol

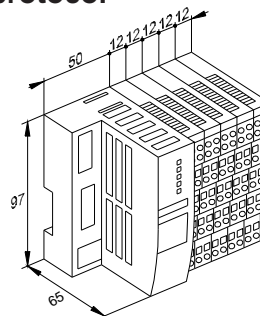

Header CANopen	RIOW CANOPEN STAND	03300010
Expansion module with 8 digital inputs	RIOW 8DI-51205053	03300008
Expansion module with 8 digital outputs	RIOW 8DO-51205043	03300007
Expansion module with 4 analog inputs	RIOW 4AI-51205050	03300006
Expansion module with 4 analog outputs	RIOW 4AO-51205039	03300005
Expansion module with 2 PT100 inputs	RIOW 2AI PT100-51205048	03300004
24V _{DC} 10A power supply for the modules	RIOW PS24-51205036	03300003
Line terminating module.	RIOW END-51205037	03300000

CAN cable for Remote I/O's

5m	CAN CABLE 5M	03780100
10m	CAN CABLE 10M	03780101
15m	CAN CABLE 15M	03780102
20m	CAN CABLE 20M	03780103
25m	CAN CABLE 25M	03780104
30m	CAN CABLE 30M	03780106
35m	CAN CABLE 35M	03780107
40m	CAN CABLE 40M	03780108
45m	CAN CABLE 45M	03780109
50m	CAN CABLE 50M	03780110
75m	CAN CABLE 75M	03780111
100m	CAN CABLE 100M	03780112
150m	CAN CABLE 150M	03780113