

CNC

8055 -MC-

Operating manual

Ref.1705

Soft: V02.2x



FAGOR AUTOMATION



FAGOR AUTOMATION

All rights reserved. No part of this documentation may be transmitted, transcribed, stored in a backup device or translated into another language without Fagor Automation's consent. Unauthorized copying or distributing of this software is prohibited.

The information described in this manual may be subject to changes due to technical modifications. Fagor Automation reserves the right to change the contents of this manual without prior notice.

All the trade marks appearing in the manual belong to the corresponding owners. The use of these marks by third parties for their own purpose could violate the rights of the owners.

DUAL-USE PRODUCTS

Products manufactured by FAGOR AUTOMATION since April 1st 2014 will include "-MDU" in their identification if they are included on the list of dual-use products according to regulation UE 428/2009 and require an export license depending on destination.

It is possible that CNC can execute more functions than those described in its associated documentation; however, Fagor Automation does not guarantee the validity of those applications. Therefore, except under the express permission from Fagor Automation, any CNC application that is not described in the documentation must be considered as "impossible". In any case, Fagor Automation shall not be held responsible for any personal injuries or physical damage caused or suffered by the CNC if it is used in any way other than as explained in the related documentation.

The content of this manual and its validity for the product described here has been verified. Even so, involuntary errors are possible, hence no absolute match is guaranteed. However, the contents of this document are regularly checked and updated implementing the necessary corrections in a later edition. We appreciate your suggestions for improvement.

The examples described in this manual are for learning purposes. Before using them in industrial applications, they must be properly adapted making sure that the safety regulations are fully met.

This product uses the following source code, subject to the terms of the GPL license. The applications *busybox* V0.60.2; *dosfstools* V2.9; *linux-ftpd* V0.17; *ppp* V2.4.0; *uteln* V0.1.1. The library *grx* V2.4.4. The linux kernel V2.4.4. The linux boot *ppcboot* V1.1.3. If you would like to have a CD copy of this source code sent to you, send 10 Euros to Fagor Automation for shipping and handling.

INDEX

About the product	5
Version history	7
Safety conditions	11
Returning conditions	15
Declaration of conformity and Warranty conditions	17
Additional notes	19
Fagor documentation.....	21

CHAPTER 1 GENERAL CONCEPTS

1.1 Keyboard.....	23
1.2 General concepts.....	25
1.2.1 P999997 text program management.....	28
1.3 Power-up.....	29
1.4 Working in M mode with the MC keyboard	30
1.5 Video off.....	30
1.6 Managing the CYCLE START key.....	30

CHAPTER 2 OPERATING IN JOG MODE

2.1 Introduction	32
2.1.1 Standard screen of the MC mode	32
2.1.2 Special screen of the MC mode	34
2.1.3 Standard screen of the MC mode. Configuration of two and half axes	36
2.1.4 Selecting a program for simulation or execution	38
2.2 Axis control	39
2.2.1 Work units	39
2.2.2 Coordinate preset.....	39
2.2.3 Managing the axis feedrate (F)	39
2.3 Machine reference (home) search	40
2.4 Zero offset table	41
2.5 Jog movement	42
2.5.1 Moving an axis to a particular position (coordinate).....	42
2.5.2 Incremental movement.....	42
2.5.3 Continuous jog	43
2.5.4 Path-jog.....	44
2.5.5 Movement with an electronic handwheel	46
2.5.6 Feed handwheel.....	47
2.5.7 Path-handwheel	48
2.6 Tool control	49
2.6.1 Tool change	51
2.6.2 Variable tool change point.....	53
2.7 Tool calibration.....	54
2.7.1 Define the tool in the tool table (level 1).....	55
2.7.2 Tool calibration without a probe (level 1)	57
2.7.3 Tool calibration with a probe (level 2)	59
2.7.4 Part centering with / without a probe (level 3)	61
2.7.5 Tabletop probe calibration (level 4).....	65
2.8 Spindle control	67
2.9 Controlling the external devices	68
2.10 ISO management.....	69

CHAPTER 3 WORKING WITH OPERATIONS OR CYCLES

3.1 Operation editing mode.....	73
3.1.1 Definition of machining conditions.....	74
3.1.2 Safety plane	75
3.1.3 Cycle level.....	76
3.2 Simulating and executing the operation.....	77
3.2.1 Background cycle editing	78
3.3 Profile milling operation.....	79
3.3.1 Definition of data	80
3.3.2 Profile definition (level 2).....	82
3.4 Surface milling and slot milling operations.....	83
3.4.1 Defining the surface milling data	84
3.4.2 Defining the grooving data	85



FAGOR AUTOMATION

CNC 8055
CNC 8055i

SOFT: V02.2x

3.5	Pocket cycle with a profile	87
3.5.1	Definition of data	89
3.5.2	Profile definition	90
3.5.3	Profile definition examples	91
3.6	Rectangular and circular boss cycles	96
3.6.1	Definition of data	97
3.7	Rectangular and circular pocket cycles	99
3.7.1	Definition of data	101
3.8	Positioning (2 levels).....	103
3.8.1	Definition of data	104
3.9	Boring operation	105
3.9.1	Definition of data	106
3.10	Reaming operation	107
3.10.1	Definition of data	108
3.11	Tapping operation.....	109
3.11.1	Definition of data (threading).....	110
3.11.2	Definition of data (thread milling)	112
3.12	Drilling and center punching operations	114
3.12.1	Definition of data	116
3.12.2	Tool withdrawal	117
3.13	Multiple positioning	118
3.13.1	Multiple positioning in several locations.....	120
3.13.2	Multiple positioning in a straight line	121
3.13.3	Multiple positioning in an arc.....	122
3.13.4	Multiple positioning in a rectangular pattern	124
3.13.5	Multiple positioning in a grid pattern	125

CHAPTER 4 OPERATING IN ISO MODE

4.1	Editing blocks in ISO mode.....	128
4.2	Programming assistance	129
4.2.1	Zero offsets and presets	129
4.2.2	Work zones	129
4.2.3	Insert labels and repetitions from label to label.....	129
4.2.4	Mirror image.....	130
4.2.5	Scaling factor	130
4.2.6	Coordinate rotation	130
4.2.7	Plane change	131

CHAPTER 5 SAVING PROGRAMS

5.1	List of saved programs	134
5.2	See the contents of a program	135
5.2.1	Seeing one of the operations in detail.....	136
5.3	Edit a new part-program	137
5.4	Saving an ISO block or a cycle.....	138
5.5	Delete a new part program	139
5.6	Copying a part-program into another one.....	140
5.7	Modify a part-program	141
5.7.1	Delete an operation.....	142
5.7.2	Add or insert a new operation	143
5.7.3	Move an operation to another position.....	144
5.7.4	Modify an existing operation	145
5.8	Managing programs using the explorer	146

CHAPTER 6 EXECUTION AND SIMULATION

6.1	Simulating or executing an operation or cycle	148
6.2	Simulating or executing a part-program.....	149
6.2.1	Simulating or executing a portion of a part-program.....	150
6.3	Simulating or executing an operation that has been saved	151
6.4	Execution mode	152
6.4.1	Tool inspection	153
6.5	Graphic representation	154



FAGOR AUTOMATION

CNC 8055
CNC 8055i

SOFT: V02.2x

ABOUT THE PRODUCT

BASIC CHARACTERISTICS OF THE DIFFERENT MODELS.

	8055i FL EN	8055 FL 8055i FL	8055 Power 8055i Power
Pendant	8055i FL EN	8055i FL	8055i Power
Enclosure	-----	8055 FL	8055 Power
USB	Standard	Standard	Standard
Block processing time	1 ms	3.5 ms	1 ms
RAM memory	1Mb	1Mb	1 Mb
Software for 7 axes	-----	-----	Option
TCP transformation	-----	-----	Option
C axis (Lathe)	-----	-----	Option
Y axis (Lathe)	-----	-----	Option
Look-ahead	100 blocks	100 blocks	200 blocks
Flash Memory 512Mb / 2Gb	512Mb	Option	Option

HARDWARE OPTIONS OF THE 8055I CNC

	Analog	Digital	Engraving
Ethernet	Option	Option	Option
RS232 serial line.	Standard	Standard	Standard
16 digital inputs and 8 outputs (I1 to I16 and O1 to O8)	Standard	Standard	Standard
Another 40 digital inputs and 24 outputs (I65 to I104 and O33 to O56)	Option	Option	Option
Probe inputs	Standard	Standard	Standard
Spindle (feedback input and analog output)	Standard	Standard	Standard
Electronic handwheels	Standard	Standard	Standard
4 axes (feedback and velocity command)	Option	Option	---
Remote CAN modules, for digital I/O expansion (RIO).	Option	Option	---
Sercos servo drive system for Fagor servo drive connection.	---	Option	---
CAN servo drive system for Fagor servo drive connection.	---	Option	---



Before start-up, verify that the machine that integrates this CNC meets the 89/392/CEE Directive.

FAGOR 
FAGOR AUTOMATION

CNC 8055
CNC 8055i

SOFTWARE OPTIONS OF THE 8055 AND 8055i CNCs.

	Model							
	GP	M	MC	MCO	EN	T	TC	TCO
Number of axes with standard software	4	4	4	4	3	2	2	2
Number of axes with optional software	7	7	7	7	-----	4 or 7	4 or 7	4 or 7
Electronic threading	-----	Stand.	Stand.	Stand.	Stand.	Stand.	Stand.	Stand.
Tool magazine management:	-----	Stand.	Stand.	Stand.	-----	Stand.	Stand.	Stand.
Machining canned cycles	-----	Stand.	Stand.	-----	Stand.	Stand.	Stand.	-----
Multiple machining	-----	Stand.	Stand.	-----	Stand.	-----	-----	-----
Solid graphics	-----	Stand.	Stand.	Stand.	-----	Stand.	Stand.	Stand.
Rigid tapping	-----	Stand.	Stand.	Stand.	Stand.	Stand.	Stand.	Stand.
Tool life monitoring	-----	Opt.	Opt.	Opt.	Stand.	Opt.	Opt.	Opt.
Probing canned cycles	-----	Opt.	Opt.	Opt.	Stand.	Opt.	Opt.	Opt.
DNC	Stand.	Stand.	Stand.	Stand.	Stand.	Stand.	Stand.	Stand.
COCOM version	Opt.	Opt.	Opt.	Opt.	-----	Opt.	Opt.	Opt.
Profile editor	Stand.	Stand.	Stand.	Stand.	-----	Stand.	Stand.	Stand.
Tool radius compensation	Stand.	Stand.	Stand.	Stand.	Stand.	Stand.	Stand.	Stand.
Tangential control	Opt.	Opt.	Opt.	Opt.	-----	Opt.	Opt.	Opt.
Retracing	-----	Opt.	Opt.	Opt.	Stand.	Opt.	Opt.	Opt.
Setup assistance	Stand.	Stand.	Stand.	Stand.	Stand.	Stand.	Stand.	Stand.
Irregular pockets with islands	-----	Stand.	Stand.	Stand.	-----	-----	-----	-----
TCP transformation	-----	Opt.	Opt.	Opt.	-----	-----	-----	-----
C axis (on Lathe)	-----	-----	-----	-----	-----	Opt.	Opt.	Opt.
Y axis (on Lathe)	-----	-----	-----	-----	-----	Opt.	Opt.	Opt.
Telediagnosis	Opt.	Opt.	Opt.	Opt.	Stand.	Opt.	Opt.	Opt.

About the product



FAGOR AUTOMATION

CNC 8055
CNC 8055i

VERSION HISTORY

Here is a list of the features added in each software version and the manuals that describe them.

The version history uses the following abbreviations:

INST	Installation manual
PRG	Programming manual
OPT	Operating manual
OPT-MC	Operating manual for the MC option.
OPT-TC	Operating manual for the TC option.
OPT-CO	Manual of the CO manual

Software V01.00 October 2010

First version.

Software V01.20 April 2011

List of features	Manual
Open communication.	INST
Improvements to Look Ahead machining.	INST
Blocks with helical interpolation in G51.	PRG
G84. Tapping with relief.	PRG

Software V01.08 August 2011

List of features	Manual
Spindle parameter OPLDECTI (P86).	INST

Software V01.30 September 2011

List of features	Manual
Gear ratio management on Sercos spindles	INST
Improved feedrate limit management (FLIMIT).	INST
New type of penetration in lathe type threading cycles.	PRG
Improved lathe type thread repair. Partial repair.	PRG
MC option: Rigid tapping with relief.	OPT-MC
TC option: New type of penetration in threading cycles.	OPT-TC
TC option: Improved thread repair. Partial and multi-entry (start) thread repair.	OPT-TC
TC option: Zig-zag entry to the groove at the starting point of the groove.	OPT-TC



FAGOR AUTOMATION

CNC 8055
CNC 8055i

List of features	Manual
CNC 8055 FL Engraving model	INST / OPT / PRG

List of features	Manual
Execution of M3, M4 and M5 using PLC marks	INST / PRG
Values 12 and 43 of variable OPMODE in conversational work mode.	INST / PRG

List of features	Manual
Auto-adjustment of axis machine parameter DERGAIN.	INST
New value for axis machine parameter ACFGAIN (P46).	INST
Value 120 of the OPMODE variable.	INST / PRG

List of features	Manual
Block processing time of 1 ms on the "CNC 8055i FL Engraving" model.	INST / OPT / PRG

List of features	Manual
Profile machining in segments. J parameter for G66 and G68 cycles.	PRG
Calls to subroutines using G functions.	INST / PRG
Anticipated tool management.	INST
Managing "PNG" and "JPG" graphic elements.	INST
New values for parameters MAXGEAR1..4 (P2..5), SLIMIT (P66) and MAXSPEED (P0).	INST
Retracing function of 2000 blocks.	INST
Quick block search.	OPT
Local subroutines within a program.	PRG
Avoid spindle stop with M30 or RESET. Spindle parameter SPDLSTOP (P87).	INST
Programming T and M06 with associated with a subroutine in the same line.	PRG
New values of the OPMODE variable.	INST / PRG
New variables: DISABMOD, GGSN, GGSO, GGSP, GGSQ, CYCCHORDERR.	INST / PRG
Possibility to set the parameters of SERCOS nodes in a non-sequential order.	INST
WRITE instruction: "\$" character followed by "P".	PRG
Cancel additive handwheel offset with G04 K0. General parameter ADIMPG (P176).	INST / PRG
Ethernet parameter NFSPROTO (P32). TCP or UDP protocol selection.	INST
Face thread repair cycle.	OPT TC
Penetration increment (step) in thread repair.	INST / OPT TC
API compliant thread.	OPT TC
Roughing by segments in inside profiling cycles 1 and 2.	INST / OPT TC
Programming the Z increment and the angle on threads.	INST / OPT TC
Reversal of the starting and final point of the face thread repair.	INST / OPT TC
Manual tool calibration without stopping the spindle during each step.	INST / OPT TC

List of features	Manual
Set PAGE and SYMBOL instructions support PNG and JPG/JPEG formats.	PRG
New values for parameters MAXGEAR1..4 (P2..5), SLIMIT (P66), MAXSPEED (P0) and DFORMAT (P1).	INST

List of features	Manual
Incremental zero offset (G158).	INST / PRG
Programs identified with letters.	OPT
Variables PRGN and EXECLEV.	INST
Korean language.	INST
Change of default value for general machine parameters: MAINOFFS (P107), MAINTASF (P162) and FEEDTYPE (P170).	INST
New variable EXTORG.	INST / PRG
Image handling via DNC.	PRG
Save/restore a trace of the oscilloscope.	OPT

List of features	Manual
PLC library.	INST
Zero offsets table in ISO mode.	OPT
Compensation of the elastic deformation in the coupling of an axis.	INST
Machine axis parameter DYNDEFREQ (P103).	INST
Change of maximum value of axis and spindle parameter NPULSES.	INST

List of features	Manual
Axis filters for movements with the handwheel. General machine parameter HDIFFBAC (P129) and machine axis parameter HANFREQ (P104).	INST
Change of maximum value of axis and spindle parameter NPULSES.	INST



Version history



FAGOR AUTOMATION

CNC 8055
CNC 8055i

SAFETY CONDITIONS

Read the following safety measures in order to prevent harming people or damage to this product and those products connected to it.

The unit can only be repaired by personnel authorized by Fagor Automation.

Fagor Automation shall not be held responsible of any physical or material damage originated from not complying with these basic safety rules.

PRECAUTIONS AGAINST PERSONAL HARM

- Interconnection of modules.
Use the connection cables provided with the unit.
- Use proper Mains AC power cables
To avoid risks, use only the Mains AC cables recommended for this unit.
- Avoid electric shocks.
In order to avoid electrical discharges and fire hazards, do not apply electrical voltage outside the range selected on the rear panel of the central unit.
- Ground connection.
In order to avoid electrical discharges, connect the ground terminals of all the modules to the main ground terminal. Before connecting the inputs and outputs of this unit, make sure that all the grounding connections are properly made.
- Before powering the unit up, make sure that it is connected to ground.
In order to avoid electrical discharges, make sure that all the grounding connections are properly made.
- Do not work in humid environments.
In order to avoid electrical discharges, always work under 90% of relative humidity (non-condensing) and 45 °C (113° F).
- Do not operate this unit in explosive environments.
In order to avoid risks, harm or damages, do not work in explosive environments.



FAGOR AUTOMATION

CNC 8055
CNC 8055i

PRECAUTIONS AGAINST PRODUCT DAMAGE

- Work environment.

This unit is ready to be used in industrial environments complying with the directives and regulations effective in the European Community.

Fagor Automation shall not be held responsible for any damage that could suffer or cause when installed under other conditions (residential or domestic environments).

- Install this unit in the proper place.

It is recommended, whenever possible, to install the CNC away from coolants, chemical product, blows, etc. that could damage it.

This unit meets the European directives on electromagnetic compatibility. Nevertheless, it is recommended to keep it away from sources of electromagnetic disturbance, such as:

- Powerful loads connected to the same mains as the unit.
- Nearby portable transmitters (radio-telephones, Ham radio transmitters).
- Nearby radio / TC transmitters.
- Nearby arc welding machines.
- Nearby high voltage lines.
- Etc.

- Enclosures.

It is up to the manufacturer to guarantee that the enclosure where the unit has been installed meets all the relevant directives of the European Union.

- Avoid disturbances coming from the machine tool.

The machine-tool must have all the interference generating elements (relay coils, contactors, motors, etc.) uncoupled.

- DC relay coils. Diode type 1N4000.
- AC relay coils. RC connected as close to the coils as possible with approximate values of $R=220 \Omega / 1 \text{ W}$ y $C=0,2 \mu\text{F} / 600 \text{ V}$.
- AC motors. RC connected between phases, with values of $R=300 \Omega / 6 \text{ W}$ y $C=0,47 \mu\text{F} / 600 \text{ V}$.

- Use the proper power supply.

Use an external regulated 24 Vdc power supply for the inputs and outputs.

- Connecting the power supply to ground.

The zero Volt point of the external power supply must be connected to the main ground point of the machine.

- Analog inputs and outputs connection.

It is recommended to connect them using shielded cables and connecting their shields (mesh) to the corresponding pin.

- Ambient conditions.

The working temperature must be between +5 °C and +40 °C (41°F and 104° F)

The storage temperature must be between -25 °C and +70 °C. (-13 °F and 158 °F)

- Monitor enclosure (CNC 8055) or central unit (CNC 8055i)

Guarantee the required gaps between the monitor or the central unit and each wall of the enclosure. Use a DC fan to improve enclosure ventilation.

- Power switch.

This power switch must be mounted in such a way that it is easily accessed and at a distance between 0.7 meters (27.5 inches) and 1.7 meters (5.5ft) off the floor.



FAGOR AUTOMATION

CNC 8055
CNC 8055i

PROTECTIONS OF THE UNIT ITSELF (8055)

- "Axes" and "Inputs-Outputs" modules.

All the digital inputs and outputs have galvanic isolation via optocouplers between the CNC circuitry and the outside.

They are protected by an external fast fuse (F) of 3.15 A 250V against overvoltage of the external power supply (over 33 Vdc) and against reverse connection of the power supply.

- Monitor.

The type of protection fuse depends on the type of monitor. See identification label of the unit itself.

PROTECTIONS OF THE UNIT ITSELF (8055I)

- Central unit.

It has a 4 A 250V external fast fuse (F).

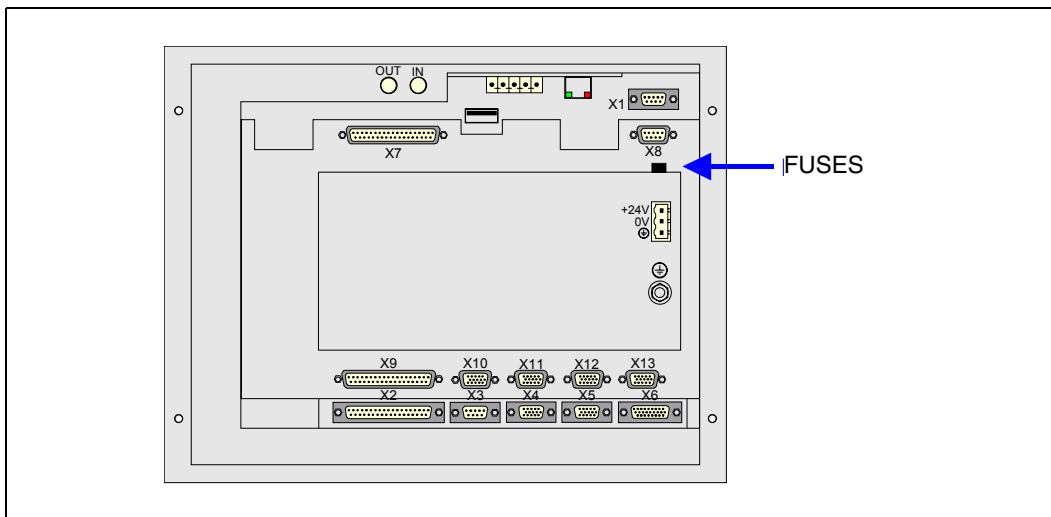

- Inputs-Outputs.

All the digital inputs and outputs have galvanic isolation via optocouplers between the CNC circuitry and the outside.

PRECAUTIONS DURING REPAIRS



Do not manipulate the inside of the unit. Only personnel authorized by Fagor Automation may access the interior of this unit.

Do not handle the connectors with the unit connected to AC power. Before manipulating the connectors (inputs/outputs, feedback, etc.) make sure that the unit is not connected to AC power.

SAFETY SYMBOLS

- Symbols that may appear in the manual.



Symbol for danger or prohibition.

It indicates actions or operations that may cause damage to people or to units.



Warning or caution symbol.

It indicates situations that could be caused by certain operations and the actions to take to prevent them.



Mandatory symbol.

*It indicates actions or operations that **MUST** be carried out.*



Information symbol.

It indicates notes, warnings and advises.

RETURNING CONDITIONS

When sending the central nit or the remote modules, pack them in its original package and packaging material. If you do not have the original packaging material, pack it as follows:

1. Get a cardboard box whose 3 inside dimensions are at least 15 cm (6 inches) larger than those of the unit itself. The cardboard being used to make the box must have a resistance of 170 kg. (375 pounds).
2. Attach a label indicating the owner of the unit, person to contact, type of unit and serial number.
3. In case of failure, also indicate the symptom and a short description of the failure.
4. Protect the unit wrapping it up with a roll of polyethylene or with similar material.
5. When sending the central unit, protect especially the screen.
6. Pad the unit inside the cardboard box with polyurethane foam on all sides.
7. Seal the cardboard box with packaging tape or with industrial staples.



FAGOR AUTOMATION

CNC 8055
CNC 8055i



Returning conditions



FAGOR AUTOMATION

CNC 8055
CNC 8055i

DECLARATION OF CONFORMITY AND WARRANTY CONDITIONS

DECLARATION OF CONFORMITY

The declaration of conformity for the CNC is available in the downloads section of FAGOR'S corporate website at <http://www.fagorautomation.com>. (Type of file: Declaration of conformity).

WARRANTY TERMS

The warranty conditions for the CNC are available in the downloads section of FAGOR's corporate website at <http://www.fagorautomation.com>. (Type of file: General sales-warranty conditions).



FAGOR AUTOMATION

CNC 8055
CNC 8055i



Declaration of conformity and Warranty conditions



FAGOR AUTOMATION

CNC 8055
CNC 8055i

ADDITIONAL NOTES

Mount the CNC away from coolants, chemical products, blows, etc. which could damage it. Before turning the unit on, verify that the ground connections have been made properly.

To prevent electrical shock at the central unit of the 8055 CNC, use the proper mains AC connector at the power supply module. Use 3-wire power cables (one for ground connection).

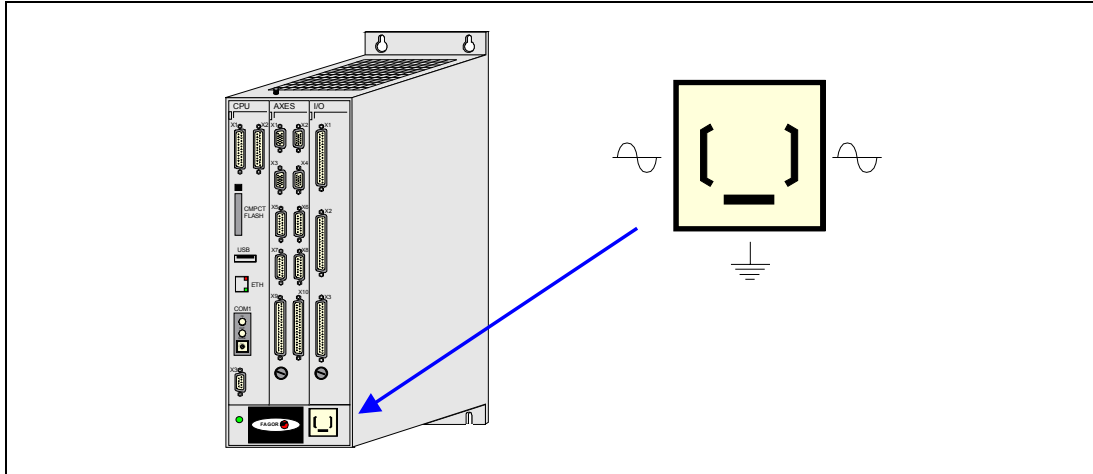

To prevent electrical shock at the monitor of the 8055 CNC, use the proper mains AC connector (A) with 3-wire power cables (one of them for ground connection).

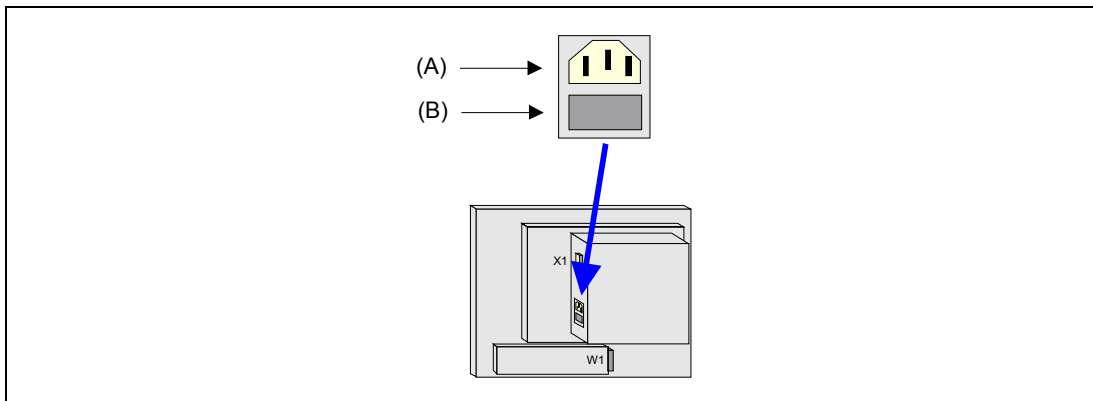

Before turning on the monitor of the 8055 CNC and verifying that the external AC line (B) fuse of each unit is the right one. See identification label of the unit itself.

In case of a malfunction or failure, disconnect it and call the technical service. Do not get into the inside of the unit.

FAGOR 

FAGOR AUTOMATION

CNC 8055
CNC 8055i



Additional notes



FAGOR AUTOMATION

CNC 8055
CNC 8055i

FAGOR DOCUMENTATION

OEM manual

It is directed to the machine builder or person in charge of installing and starting-up the CNC.

USER-M manual

Directed to the end user.

It describes how to operate and program in M mode.

USER-T manual

Directed to the end user.

It describes how to operate and program in T mode.

MC Manual

Directed to the end user.

It describes how to operate and program in MC mode.

It contains a self-teaching manual.

TC Manual

Directed to the end user.

It describes how to operate and program in TC mode.

It contains a self-teaching manual.

MCO/TCO model

Directed to the end user.

It describes how to operate and program in MCO and TCO mode.

Examples-M manual

Directed to the end user.

It contains programming examples for the M mode.

Examples-T manual

Directed to the end user.

It contains programming examples for the T mode.

WINDNC Manual

It is directed to people using the optional DNC communications software.

It is supplied in a floppy disk with the application.

WINDRAW55 Manual

Directed to people who use the WINDRAW55 to create screens.

It is supplied in a floppy disk with the application.



FAGOR AUTOMATION

CNC 8055
CNC 8055i



Fagor documentation



FAGOR AUTOMATION

CNC 8055
CNC 8055i

GENERAL CONCEPTS

1

1.1 Keyboard

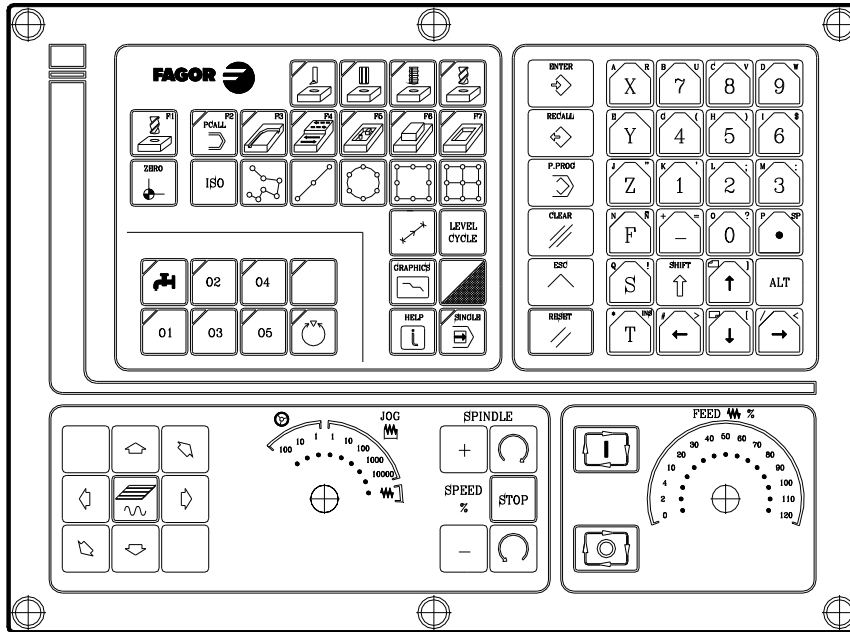

Alphanumeric keyboard and command keys

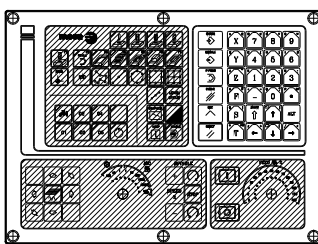

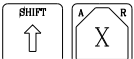
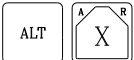
-  Select the X character.
-  Select the A character.
-  Select the R character.

Specific keys of the MC model

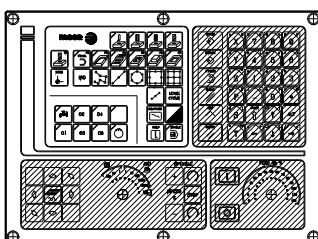

- These keys may be used for:
- Selecting and defining the machining operations.
 - Govern the external devices.
 - Selecting the spindle work mode.
 - Selecting the single block or automatic execution Mode.



FAGOR AUTOMATION

CNC 8055
CNC 8055i

-MC- OPTION
SOFT: V02.2X

JOG keys

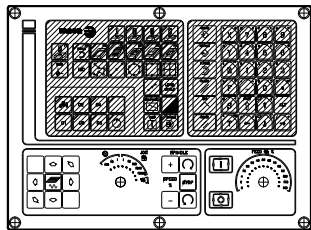

These keys may be used for:

- Moving the axes of the machine.
- Governing the spindle.
- Modifying the feedrate of the axes and the spindle speed.
- Starting and stopping the execution.

1.

GENERAL CONCEPTS
Keyboard



FAGOR AUTOMATION

CNC 8055
CNC 8055i

·MC· OPTION
SOFT: V02.2X

1.2 General concepts

It offers all the features of the M model plus those specific of the MC mode. For example, the CNC setup must be done in M mode.

In MC work mode, programs P900000 through P999999 are reserved for the CNC itself; in other words, the user cannot use them as part-programs.

On the other hand, in order to work in MC mode, the CNC must have programs P999997 and P999998 stored in its memory. Both programs are related to the software version and, consequently, are not supplied by Fagor Automation. Whenever the CNC detects a new software version, it updates these programs automatically and, for safety, it makes a copy of the old ones in the KeyCF.

Likewise, subroutines 0000 through 8999 are free to use and subroutines 9000 through 9999 are reserved for the CNC.



Programs P999997 and P999998 are associated with the software version. Fagor Automation shall not be held responsible of the CNC's performance if programs P999997 and P999998 have been deleted from memory or do not match the software version.

Subroutines reserved for the CNC

Some of the subroutines reserved for the CNC have the following meaning:

- 9998 Subroutine that the CNC will execute at the beginning of each part-program.
- 9999 Subroutine that the CNC will execute at the end of each part-program.

Every time a new part-program is edited, the CNC inserts a call to the relevant subroutine at the beginning and at the end of the program.

Both subroutines must be defined by the machine manufacturer, even when no operation is to be carried out at the beginning and at the end of the part-program. If they are not defined, the CNC will issue an error message when trying to execute a part-program.

Example of how to define subroutine 9998.

```
(SUB 9998)      ; Definition of subroutine 9998.
...            ; Program blocks defined by the OEM.
(RET)          ; End of subroutine.
```

OEM (manufacturer's) parameters

OEM parameters and subroutines with OEM parameters can only be used in OEM programs; those defined with the [O] attribute. Modifying one of these parameters in the tables requires an OEM password.

When using OEM parameters in the configuration programs, this program must have the [O] attribute; otherwise, the CNC will issue an error when editing the user cycles that refer to OEM parameters in write mode.



Programs reserved for the CNC

Some of the programs reserved for the CNC have the following meaning:

P999998

It is a program of subroutines that the CNC uses to interpret the programs edited in MC format and execute them later on.



This program must not be modified. If this program is modified or deleted, Fagor Automation will not be held responsible of the CNC's performance.

If the manufacturer needs to create his own subroutines (for home search, tool change, etc.), as well as subroutines 9998 and 9999, they must be included in another program, for example P899999.

P999997

It is a text program that contains:

- The sentences and texts that will be displayed on the various screens of the MC mode.
- The help texts for the icons, in the work cycles, that are shown on the lower left side of the screen.
- The messages (MSG) and errors (ERR) that may come up at the MC model.

All the texts, messages and errors that may be translated into the desired language.



When modifying program 999997, it is recommended to make a backup copy of it because the CNC replaces that program when selecting another language or updating the software version.

Considerations about the texts.

The format of a line is as follows:

`;Text number - explanatory comment (not displayed) - $Text to be displayed`

All the program lines must begin with the ";" character and the text to be displayed must be preceded by the "\$" symbol. If a line begins with ";;", the CNC assumes that the whole line is a program comment.

Examples:

<code> ;44 \$M/MIN</code>	Is message 44 and displays the text "M/MIN"
<code> ;;General text</code>	The CNC treats it as a comment
<code> ;;44 Feedrate \$M/MIN</code>	The CNC treats it as a comment
<code> ;44 Feedrate \$M/MIN</code>	Is message 44 whose hidden explanatory comment is "Feedrate" and displays the text "M/MIN"

Considerations about the messages.

The format must be respected. Only the text after SAVEMSG may be translated:

Example:

Original message:	N2002(MSG"SAVEMSG: DRILLING 1")
Translated message:	N2002(MSG"SAVEMSG: 1 ZULAKETA ZIKLOA")

1.

GENERAL CONCEPTS
General concepts



FAGOR AUTOMATION

CNC 8055
CNC 8055i

·MC· OPTION
SOFT: V02.2X

Considerations about the errors.

The format must be respected. Only the text between quote marks ("text") may be translated.

Example:

Original text:	N1021(ERROR"TALADRADO 1: F=0")
Translated text:	N1001(ERROR"1 ZULAKETA ZIKLOA: F=0")

P998000 ... P998999

They are the profiles for the pocket-with-profile cycle that are defined by the user with the profile editor. In the MC mode, the user defines them with 3 digits (from 0 to 999) and the CNC saves them internally as P998xxx.

P997000 ... P997999

They are the profiles for the profile milling operation that are defined by the user with the profile editor. In the MC mode, the user defines them with 3 digits (from 0 to 999) and the CNC saves them internally as P997xxx.



GENERAL CONCEPTS
General concepts



FAGOR AUTOMATION

CNC 8055
CNC 8055i

·MC· OPTION
SOFT: V02.2X

1.2.1 P999997 text program management

On power up, the CNC copies the texts of program P999997 into the system memory.

- It checks if program P999997 is in user memory, if not, it looks in the KeyCF and if it is not there either, it assumes the default ones and copies them into program P999997 of the user memory.
- When selecting mainland Chinese, it ignores program P999997 and it always assumes the default ones.

If when switching from M mode to MC or MCO mode, it cannot find program P999997 because it has been deleted, it is initialized like on power-up.

When modifying the texts of program P999997, turn the CNC off and back on so it assumes the new texts.

The CNC carries out the following operations when changing the language, the software version and when adding MC, MCO conversational modes (new software features):

- It copies, for safety, the texts that were being used into KeyCF as program P999993.
- It deletes the program P999997 that may be in the KeyCF.
- It assumes the new texts that are provided by default and copies them into program P999997 of the user memory.

To change the texts, after modifying program P999997, turn the CNC off and back on so it assumes the new texts.

1.**GENERAL CONCEPTS**
General concepts

FAGOR AUTOMATION

CNC 8055
CNC 8055i·MC· OPTION
SOFT: V02.2X

1.3 Power-up

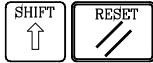

On power-up and after the keystroke sequence [SHIFT] [RESET], the CNC shows "page 0" defined by the manufacturer; if there is no "page 0", it shows the standard screen of the work mode. Press any key to access the work mode.

The standard screen of the MC mode is the following:

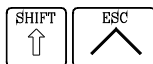
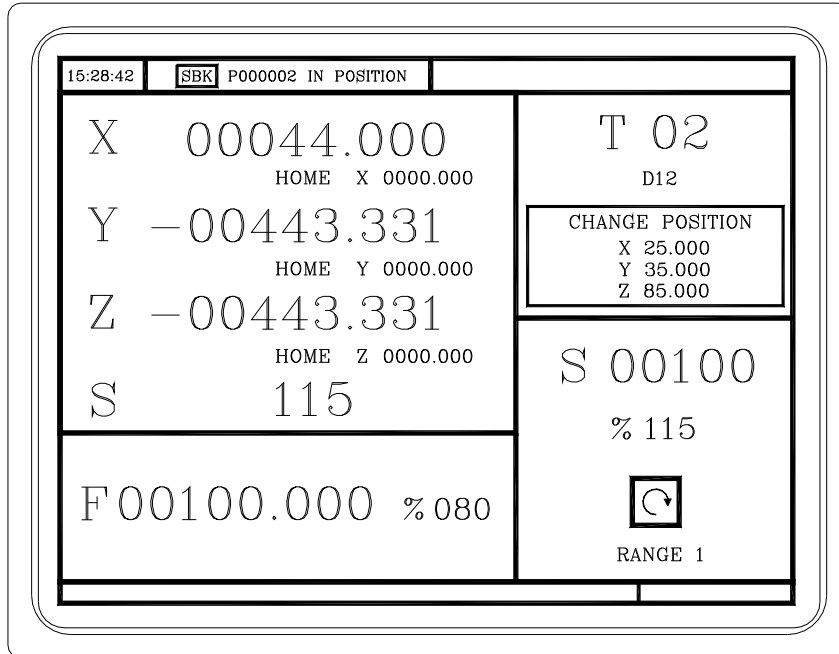

There are 2 work modes: MC work mode and M work mode. Press the key sequence [SHIFT] [ESC] to go from one work mode to the other.



*The CNC setup must be done in M mode.
Likewise, some errors must be eliminated in M mode.*

1.

GENERAL CONCEPTS
Power-up

1.4 Working in M mode with the MC keyboard

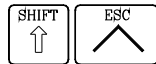

There are 2 work modes: MC work mode and M work mode. Press the key sequence [SHIFT] [ESC] to go from one work mode to the other.

The MC keyboard is designed to also be able to work in M mode. In M mode, use the alphanumeric keyboard and the keys that replace the softkeys F1 through F7.

Alphanumeric keyboard:

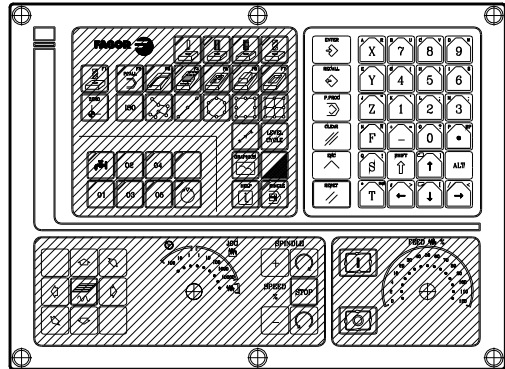

The keys that replace the softkeys F1 through F7 are:

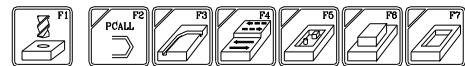

1.5 Video off

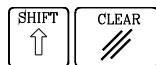

The keystroke sequence [SHIFT] [CLEAR] clears the CRT screen (it goes blank). Press any key to restore the image.

Also, any message (PLC, program, etc.) restores the CNC image.

1.6 Managing the CYCLE START key

In order to avoid undesired executions when pressing key sequences that are not supported in MC mode, the CNC changes the "Start" icon at the top of the window from green to gray and shows a message indicating that it is an invalid action.

For example, if "M3 Start" is pressed (sequence not supported in MC mode) while a part-program is selected, the CNC issues a warning and prevents the selected part-program from running when detecting the "Start" key.



FAGOR AUTOMATION

CNC 8055
CNC 8055i

·MC· OPTION
SOFT: V02.2X

OPERATING IN JOG MODE

2

The standard screen of the MC mode is the following:

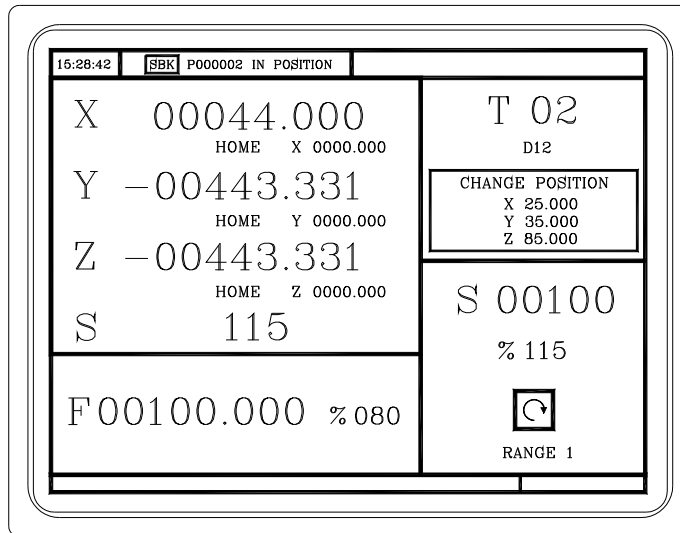

When pressing the two-color key, the CNC shows the special screen of the MC mode.

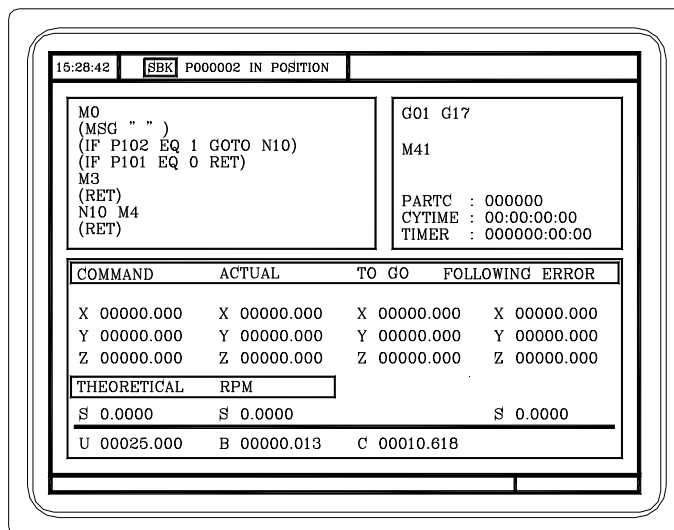
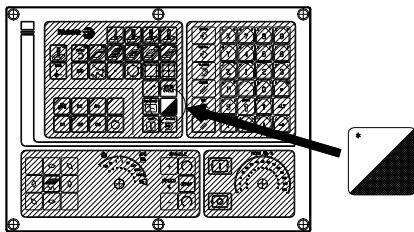

FAGOR AUTOMATION

CNC 8055
CNC 8055i

·MC· OPTION
SOFT: V02.2X

2.1 Introduction

2.1.1 Standard screen of the MC mode

The standard screen of the MC mode offers the following data:

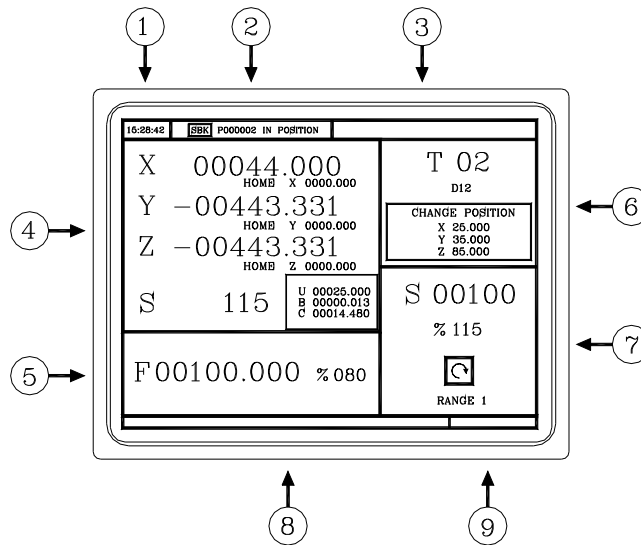

1. Clock.
2. This window may show the following data:
 - SBK when "single block" execution mode is selected.
 - DNC when the DNC mode is active.
 - P.... Number of the program currently selected.
 - Message "In position" - "Execution" - "Interrupted" - "RESET".
 - PLC messages.
3. This window shows the CNC messages.
4. This window may show the following data:
 - X, Y, Z coordinates of the axes.
 - In small characters, the axis coordinates referred to machine reference zero. These values are useful when letting the user define a tool change point (see zone 6) The CNC shows this data when text 33 of program 999997 has not been defined.
 - The coordinates of the auxiliary axes that are defined.
 - The real spindle rpm.
5. The information shown in this window depends on the position of the left switch.
 - In all cases, it shows the axis feedrate "F" currently selected and the % of F being applied.
 - When feed-hold is active, the color of the feedrate value changes.



FAGOR AUTOMATION

CNC 8055
CNC 8055i

-MC- OPTION
SOFT: V02.2X

Here are all the possible cases.

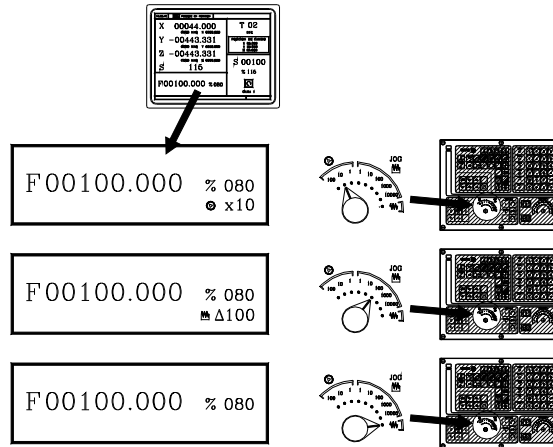

- This window shows, in large characters, the selected tool number "T" and, in small characters, the "D" offset associated with the tool. If the tool number and the offset number are the same, the CNC will not show the "D" value.

This window also shows the coordinates of the tool change point referred to machine reference zero. The CNC does not show this window when text 47 of program 999997 has not been defined.

- This window shows everything related to the spindle:

The real spindle speed "S".

The spindle status. It is represented with an icon and may be turning clockwise, counterclockwise or stopped.

The % of spindle speed being applied.

The active spindle speed gear (range). The CNC does not show this data when text 28 of program 999997 has not been defined.

- When accessing a work cycle, this window shows the help text associated with the selected icon.

That help text must be defined in program P999997 and edited in the desired language. See chapter "1 General concepts".

- Reserved.

Displaying the active PLC messages

At the screen, press [+] of the alphanumeric keyboard, the CNC shows a window with all the active PLC messages. Besides, this window is also displayed whenever there is a program in execution.

The [↑][↓][PG UP][PG DW] keys are used to move around the messages. The [ESC] key is used to close the window.

The window is only displayed when there are more than one active message.

Direct access to the oscilloscope

The oscilloscope may be accessed from the standard screen by pressing "7" and then "1" as long as no data is being written into any field.

2.1.2 Special screen of the MC mode

The special screen of the MC mode offers the following data:

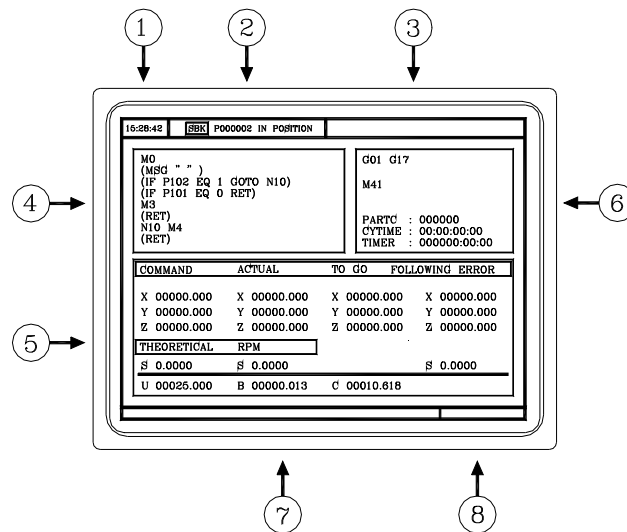

1. Clock.
2. This window may show the following data:
 - SBK when "single block" execution mode is selected.
 - DNC when the DNC mode is active.
 - P.... Number of the program currently selected.
 - Message "In position" - "Execution" - "Interrupted" - "RESET".
 - PLC messages.
3. This window shows the CNC messages.
4. This window shows the lines of the program currently selected.
5. The X, Y, Z axes have the following fields:

COMMAD	It indicates the programmed coordinate or position that the axis must reach.
ACTUAL	It indicates the actual (current) position of the axis.
TO GO	It indicates the distance which is left to run to the programmed coordinate.
FOLLOWING ERROR	Difference between the theoretical value and the real value of the position.

The spindle (S) has the following fields:

THEORETICAL	Programmed theoretical S speed.
RPM	Speed in rpm.
M/MIN	Speed in meters per minute.
FOLLOWING ERROR	When working with spindle orientation (M19), it indicates the difference between the theoretical and the real speeds.

The auxiliary axes only show the real current position of the axis.

2.

6. This window shows the status of the "G" functions and the auxiliary "M" functions that are active. Likewise, it shows the value of the variables.

PARTC It indicates the number of consecutive parts executed with the same part-program.

Every time a new program is selected, this variable is reset to "0".

CYTIME It indicates the time elapsed while executing the part. It is given in "hours: minutes: seconds: hundredths of a second" format.

Every time a part-program execution starts, even when repetitive, this variable is reset to "0".

TIMER It indicates the count of the timer enabled by PLC. It is given in "hours: minutes: seconds" format.

7. Reserved.

8. Reserved.

Displaying the active PLC messages

At the screen, press [+] of the alphanumeric keyboard, the CNC shows a window with all the active PLC messages. Besides, this window is also displayed whenever there is a program in execution.

The [↑][↓][PG UP][PG DW] keys are used to move around the messages. The [ESC] key is used to close the window.

The window is only displayed when there are more than one active message.

Direct access to the oscilloscope

The oscilloscope may be accessed from the auxiliary screen by pressing "7" and then "1" as long as no data is being written into any field.

2.1.3 Standard screen of the MC mode. Configuration of two and half axes

A two-and-a-half-axis configuration is a milling machine where the X and Y axes are motorized and the Z axis is set as a DRO axis (display only). In this configuration, the Z axis is moved manually.

The CNC interface for this type of configuration looks like this.

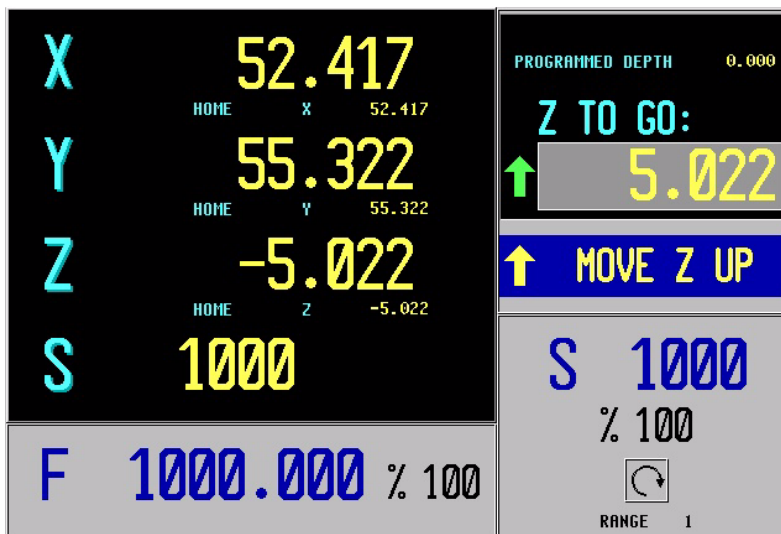

Editing and execution

The cycles are edited, stored and simulated just like a 3-axis configuration.

The most significant difference lies in the execution because the operator must move the Z axis by hand. The standard screen shows the operations to be carried out by the operator. In each case, it shows the status of the Z axis and the various actions to be executed by the operator.

- Move Z up (it shows an icon next to the final Z coordinate).
The operator must move the axis up manually. When the Z axis is in position, the message will change.
- Move Z down (it shows an icon next to the final Z coordinate).
The operator must move the axis down manually. When the Z axis is in position, the message will change.
- Press CYCLE START.
The operator must press [CYCLE START] to begin the X-Y movement in automatic.
- Moving in X-Y.
The machine is moving in X-Y. When a Z axis move is required, the machine will stop and it will request the operator's intervention.
- Tool inspection.
It went into tool inspection.

2.

OPERATING IN JOG MODE
Introduction

FAGOR 

FAGOR AUTOMATION

CNC 8055
CNC 8055i

·MC· OPTION
SOFT: V02.2X

Canned cycles

Not all the cycles can be applied to a two-and-a-half-axis configuration. The following cycles are permitted. In some of these cycles, some data has been eliminated to adapt them to the two-and-a-half-axis configuration. This data referred to operations of the Z axis.

- Positioning 1 and 2.
- Profile milling and profile 1 milling.
- Surface milling.
- Slot milling.
- 2D profile pocket.
- Rectangular and circular boss.
- Simple, rectangular and circular pocket 1 and 2.
- Center punching.
- Drilling 1.
- Reaming.
- Boring 1 and 2.
- Multiple positioning, point to point, linear, in arc 1 and 2, in grid and rectangular patterns.

2.

OPERATING IN JOG MODE
Introduction

FAGOR 

FAGOR AUTOMATION

CNC 8055
CNC 8055i

·MC· OPTION
SOFT: V02.2X

2.1.4 Selecting a program for simulation or execution

When selecting a part-program or operation saved as part of a part-program for simulation or execution, the CNC selects that part-program and shows it highlighted next to the green "start" symbol in the top center window.

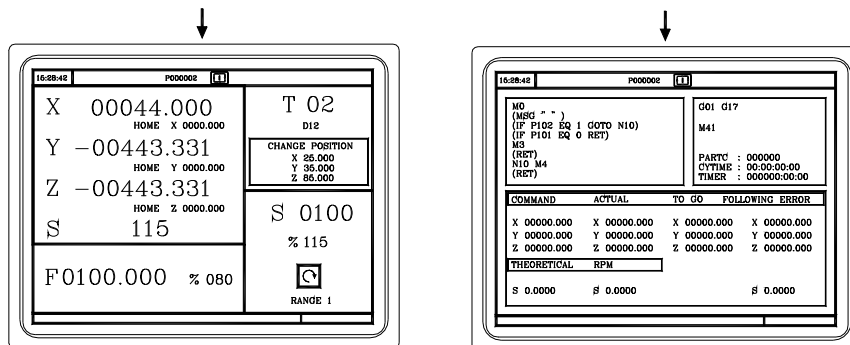

When the top center window shows the part-program selected next to the green "start" symbol, the CNC acts as follows:

- If [START] is pressed, the CNC executes the part-program that is selected.
- If [CLEAR] is pressed, the CNC de-selects the part-program and removes it from the top center window.

2.

OPERATING IN JOG MODE
Introduction



FAGOR AUTOMATION

CNC 8055
CNC 8055i

.MC- OPTION
SOFT: V02.2X

2.2 Axis control

2.2.1 Work units

When accessing the MC mode, the CNC assumes the work units "mm or inches", "mm/min. or mm/rev", etc. selected by machine parameter.

To modify those values, access the M mode and change the corresponding machine parameter.

2.2.2 Coordinate preset

The coordinates must be preset on one axis at a time proceeding as follows:

1. Press the key of the desired axis, [X], [Y] or [Z].

The CNC will highlight the coordinate of that axis indicating that it is selected.

2. Key in the value to preset the axis.

To quit the preset mode, press [ESC].

3. Press [ENTER] for the CNC to assume that value as the new value for the point.

The CNC requests confirmation of the command. Press the [ENTER] to confirm it or [ESC] to quit the preset mode.

2.2.3 Managing the axis feedrate (F)

To set a particular axis feedrate value, proceed as follows:

1. Press the [F] key.

The CNC will highlight the current value that it is selected.

2. Key in the desired new feedrate value.

To quit the preset selection mode, press [ESC].

3. Press [START] for the CNC to assume that value as the new value for axis feedrate.

2.

2.3 Machine reference (home) search

Home search may be done in 2 ways:

- Homing all the axes.
- Homing a single axis.

Homing all the axes

To home all the axes, press [ZERO].

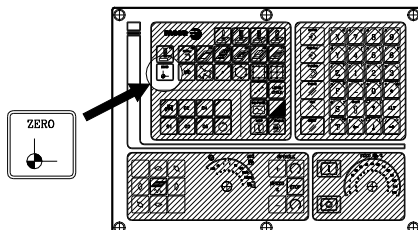

The CNC requests confirmation of the command (text 48 of program 999997). Press [START], the CNC will execute the home search subroutine defined by the OEM in general machine parameters P34 (REFPSUB).



After searching home this way, the CNC will maintain the part zero or zero offset active at the time. A home search subroutine (general machine parameter P34 other than 0) must be defined when using this method. Otherwise, the CNC will display the corresponding error.

Homing a single axis

To home a single axis, press the key of the desired axis and the key for home search.

In either case, the CNC requests confirmation of the command (text 48 of program 999997).

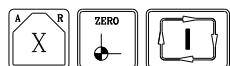

It homes the X axis.

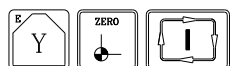

It homes the Y axis.

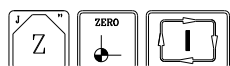

It homes the Z axis.



After searching home this way, the CNC will not maintain the part zero or zero offset active at the time and assumes the machine reference zero as the new part zero.

2.4 Zero offset table

It is possible to manage the zero offset table from the conversational mode (G54... G59, G159N7 ... G159N20). This table contains the same values as that of the conversational mode.

Press the [ZERO] key to access the zero offset table as well as to get out of it. The zero offset table may be accessed in the following ways.

- From the standard screen, as long as no axis is selected. The CNC will request confirmation of the command.
- From ISO mode, when the "zero offsets and presets" cycle is selected.

The zero offset table looks like this. It shows all the offsets, PLC offset included, and their value in each axis.

	X	Y	Z	V
PLC	0.0000	0.0000	0.0000	0.0000
G54	0.0000	0.0000	0.0000	0.0000
G55	0.0000	0.0000	0.0000	0.0000
G56	0.0000	0.0000	0.0000	0.0000
G57	0.0000	0.0000	0.0000	0.0000
ΔG58	0.0000	0.0000	0.0000	0.0000
ΔG59	0.0000	0.0000	0.0000	0.0000

When scrolling the focus through the table, the elements appear in different colors as follows.

Color	Meaning
Green background. Text in white.	The real value of the table and the value shown on the screen are the same.
Red background. White text.	The real value of the table and the value shown on the screen are NOT the same. The value on the table has been changed, but it has not been validated. Press [ENTER] to validate the change.
Blue background.	The zero offset is active. Two origins may be active simultaneously, one absolute (G54 ... G57, G159N7 ... G159N20) and another incremental (G58-G59).

How to edit the table data

The following operations are possible in the zero offset table. Press [ENTER] to validate any changes.

- Editing a zero offset.
It is edited one axis at a time. Select a data with the focus and edit its value. If the magnifying glass is placed on top of an offset (G54 ... G59, G159N7 ... G159N20), editing start on the first axis of that offset.
- Load the active zero offset into the table.
Position the magnifying glass over the offset you wish to define (G54 ... G59, G159N7 ... G159N20) and click on the [RECALL] key. The active preset is saved in the selected zero offset.
If instead of placing the focus on a zero offset, it is placed on one of the axes, only that axis will be affected.
- Deleting a zero offset.
Position the magnifying glass over the offset that you wish to erase (G54 ... G59, G159N7 ... G159N20) and click on the [CLEAR] key. All the axes of that zero offset are reset to zero.
If instead of placing the focus on a zero offset, it is placed on one of the axes, only that axis will be affected.

2.

OPERATING IN JOG MODE
Zero offset table



FAGOR AUTOMATION

CNC 8055
CNC 8055i

-MC- OPTION
SOFT: V02.2X

2.5 Jog movement

When making a move in manual, both in jog and with handwheels, the moving axis appears in reverse video.

- With gantry axes, only the master axis is highlighted.
- With a path handwheel, no axis is highlighted; but it is in path-jog.

2.

OPERATING IN JOG MODE
Jog movement

2.5.1 Moving an axis to a particular position (coordinate)

The movements of axes to a particular coordinate are made one at a time as follows.

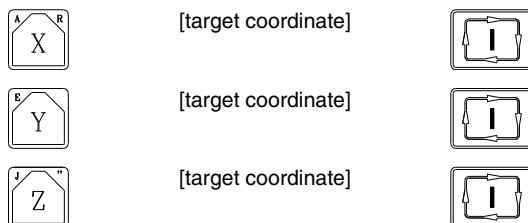

2.5.2 Incremental movement

Turn the JOG switch to one of the JOG positions.

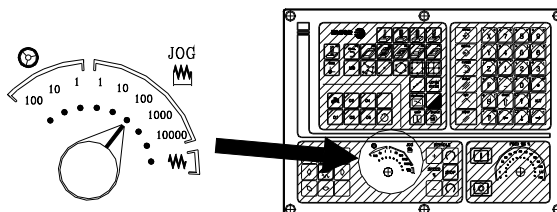

The incremental movement must be made one axis at a time. To do that, press the JOG keys for the direction of the axis to be jogged.

Every time a key is pressed, the corresponding axis moves the amount set by the switch. This movement is made at the selected feedrate (F).

Switch position	Distance
1	0.001 mm or 0.0001 inches
10	0.010 mm or 0.0010 inches
100	0.100 mm or 0.0100 inches
1000	1.000 mm or 0.1000 inches
10000	10.000 mm or 1.0000 inches

2.5.3 Continuous jog

Place the movement selector in the continuous-jog position and select at the feedrate override switch (FEED) the percentage (0% to 120%) of the feedrate to be applied.

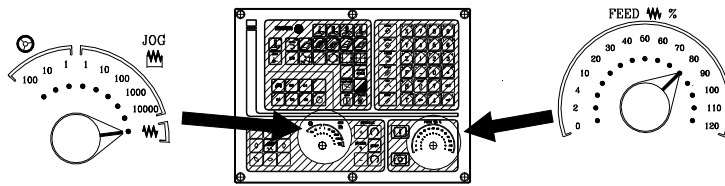

The continuous jog must be made one axis at a time. To do that, press the JOG keys for the direction of the axis to be jogged.

The axis moves at a feedrate equal to the selected percentage (0% to 120%) of feedrate "F".



If while jogging an axis, the rapid key is pressed, the axis will move at the maximum feedrate possible, set by axis machine parameter "G00FEED". This feedrate will be applied while that key is kept pressed and the previous feedrate will be restored when that key is released.

Depending on the status of the general logic input "LATCHMAN", the movement will be carried out as follows:

- If the PLC sets this mark low, the axis will be jogged while pressing the corresponding Jog key.
- If the PLC sets this mark high, the axes will start moving from the moment the JOG key is pressed until the same is pressed again, or another JOG key is pressed. In this case, the movement will be transferred to that indicated by the new key.

The following cases are possible when working with "F" in mm/rev:

- The spindle is running.
- The spindle is stopped, but a spindle speed S has been selected.
- The spindle is stopped and no spindle speed S has been selected.

The spindle is running.

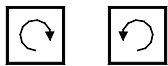

The CNC moves the axes at the programmed F.

The spindle is stopped, but a spindle speed S has been selected.

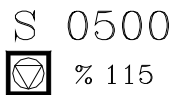

The CNC calculates the feedrate F in mm/min for the theoretical S and moves the axis.

For example if "F 2.000" and "S 500":

$$F \text{ (mm/min)} = F \text{ (mm/rev)} \times S \text{ (mm/rev)} = 2 \times 500 = 1000 \text{ mm/min.}$$

The axis moves at a feedrate of 1000 mm/min.

The spindle is stopped and no spindle speed S has been selected.

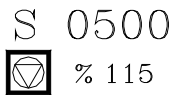

If F = 0, the CNC moves the axes in rapid.

If F is other than 0, the axes can only be moved by pressing the rapid key and an axis key. The CNC moves the axis in rapid.

2.

2.5.4 Path-jog

The "path jog" mode acts when the switch is in one of the continuous or incremental jog positions. This feature may be used to act upon the jog keys of an axis to move both axes of the plane at the same time for chamfering (straight sections) and rounding (curved sections). The CNC assumes as "Path jog" the keys associated with the X axis.



This feature must be managed from the PLC. This feature is usually activated and deactivated by means of an external push-button or a key configured for that purpose, as well as the selection of the type of path.

The next example uses the [O2] key to activate and deactivate the path-jog mode and the [O3] key to indicate the type of movement.

Activate / deactivate the path-jog mode.

DFU B29 R561 = CPL M5054

It selects the type of movement, straight section or arc section.

DFU B31 R561 = CPL M5053

While in jog mode and having selected path-jog, the CNC shows the following information:

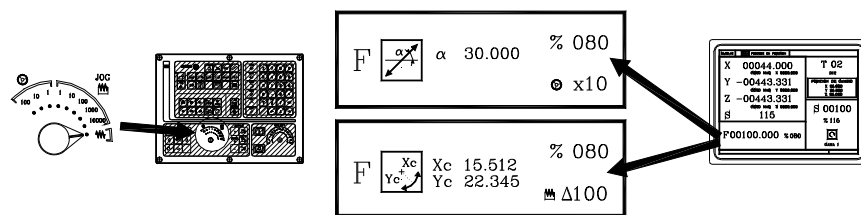

For a linear movement (top figure), the path angle must be defined and for an arc (bottom figure), the center coordinates must be indicated. To define these variables, press the [F] key and then one of these keys: [←] [→] [↑] [↓].

Operation in path-jog mode

The "path jog" mode is only available with the X axis keys. When pressing one of the keys associated with the X axis, the CNC behaves as follows:

Switch position	Path-jog	Type of movement
Continuous jog	Deactivated	Only the axis and in the indicated direction
	Activated	Both axes in the indicated direction and along the indicated path
Incremental jog	Deactivated	Only the axis, the selected distance and in the indicated direction
	Activated	Both axes, the selected distance and in the indicated direction, but along the indicated path
Handwheel		It ignores the keys.

The rest of the jog keys always work in the same way, whether "path jog" is on or off. The rest of the keys move only the axis and in the indicated direction.

The movements in path-jog may be aborted by pressing the [STOP] key or setting the jog switch to one of the handwheel positions.

Considerations about the jog movements

This mode assumes as axis feedrate the one selected in jog mode and it will also be affected by the feedrate override switch. If F0 is selected, it assumes the one indicated by machine parameter "JOGFEED (P43)". This mode ignores the rapid jog key.

Path-jog movements respect the travel limits and the work zones.

2.

OPERATING IN JOG MODE
Jog movement

FAGOR 

FAGOR AUTOMATION

CNC 8055
CNC 8055i

·MC· OPTION
SOFT: V02.2X

2.5.5 Movement with an electronic handwheel

This option may be used to govern the movements of the machine using an electronic handwheel. To do that, turn the left switch to any of the handwheel positions.

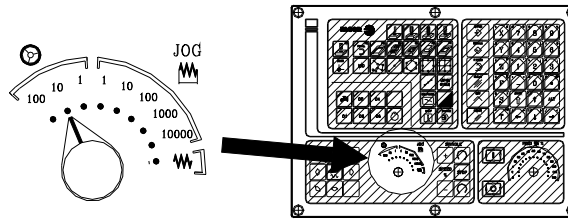

The positions available are 1, 10 and 100; they indicate the multiplying factor being applied besides the internal x4 to the feedback pulses supplied by the electronic handwheel.

Switch position	Distance per turn
1	0.100 mm or 0.0100 inches
10	1.000 mm or 0.1000 inches
100	10.000 mm or 1.0000 inches



It may happen that depending on the turning speed and the selector switch position, the CNC be demanded a faster feedrate than the maximum allowed (axis machine parameter "G00FEED"). The CNC will move the axis the indicated distance but at the maximum feedrate allowed.

The machine has an electronic handwheel

Once the desired switch position has been selected, press one of the JOG keys for the axis to be jogged. The bottom of the screen shows the selected axis in small characters and next to the handwheel symbol.

When using a FAGOR handwheel with an axis selector button, the axis may be selected as follows:

- Push the button on the back of the handwheel. The CNC select the first axis and it highlights it.
- When pressing the button again, the CNC selects the next axis and so on in a rotary fashion.
- To deselect the axis, hold the button pressed for more than 2 seconds.

Once the axis has been selected, it will move as the handwheel is being turned and in the direction indicated by it.

The machine has two or three electronic handwheels

Each axis will move as the corresponding handwheel is being turned according to the switch position and in the direction indicated by it.

When the machine has a general handwheel and individual handwheels (associated with each axis of the machine), the individual handwheels have the highest priority; i.e. when moving an individual handwheel, the CNC will ignore the general handwheel.

2.

OPERATING IN JOG MODE
Jog movement



FAGOR AUTOMATION

CNC 8055
CNC 8055i

·MC· OPTION
SOFT: V02.2X

2.5.6 Feed handwheel

Usually, when making a part for the first time, the machine feedrate is controlled by means of the feedrate override switch.

From this version on, it is also possible to use the machine handwheels to control that feedrate. This way, the machining feedrate will depend on how fast the handwheel is turned.



This feature must be managed from the PLC. Usually, this feature is turned on and off using an external push button or key configured for that purpose.

The following CNC variables return the number of pulses the handwheel has turned.

HANPF	provides the number of pulses of the 1st handwheel.
HANPS	provides the number of pulses of the 2nd handwheel.
HANPT	provides the number of pulses of the 3rd handwheel.
HANPFO	provides the number of pulses of the 4th handwheel.

2.

OPERATING IN JOG MODE
Jog movement

FAGOR 

FAGOR AUTOMATION

CNC 8055
CNC 8055i

·MC· OPTION
SOFT: V02.2X

2.5.7 Path-handwheel

The "path handwheel" mode acts when the switch is in one of the handwheel positions. With this feature, it is possible to jog two axes of the plane at the same time along a linear path (chamfer) or circular path (rounding) with a single handwheel. The CNC assumes as the path handwheel the general handwheel or, when this one is missing, the one associated with the X axis.



This feature must be managed from the PLC. This feature is usually activated and deactivated by means of an external push-button or a key configured for that purpose, as well as the selection of the type of path.

The next example uses the [O2] key to activate and deactivate the path-handwheel mode and the [O3] key to indicate the type of movement.

Activate / deactivate the path-handwheel mode.

DFU B29 R561 = CPL M5054

It selects the type of movement, straight section or arc section.

DFU B31 R561 = CPL M5053

While in handwheel mode and having selected path-handwheel, the CNC shows the following information:

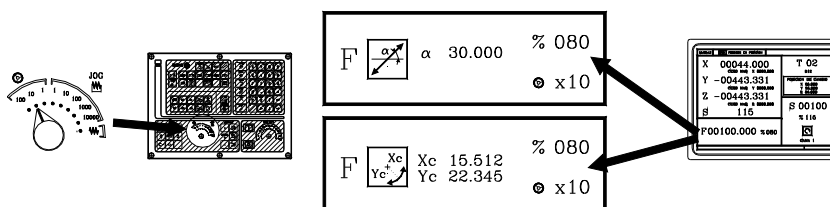

For a linear movement (top figure), the path angle must be defined and for an arc (bottom figure), the center coordinates must be indicated. To define these variables, press the [F] key and then one of these keys: [←] [→] [↑] [↓].

Operation in path-handwheel mode

When selecting the path handwheel mode, the CNC behaves as follows.

- If there is a general handwheel, it will be the one working in path handwheel mode. The individual handwheels, if any, will remain associated with the corresponding axes.
- If there is no general handwheel, the individual handwheel associated with the X axis then works in path-handwheel mode.

The movements in path-handwheel may be aborted by pressing the [STOP] key or setting the jog switch to one of the continuous or incremental positions.



FAGOR AUTOMATION

CNC 8055
CNC 8055i

·MC· OPTION
SOFT: V02.2X

2.6 Tool control

The standard screen of the MC mode offers the following tool data.

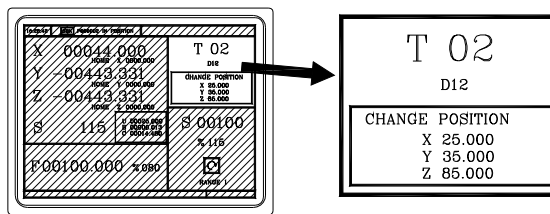

This window displays the following information:

- In large characters, the tool "T" number currently selected.
- The "D" offset number associated with the tool.
- The position values of the tool change point. The CNC does not show this window when text 47 of program 999997 has not been defined.

To select another tool, follow these steps:

1. Press the [T] key.
The CNC highlights the tool number.
2. Key in the number of the tool to be selected.
To quit the preset selection mode, press [ESC].
3. Press [START] for the CNC to select the new tool.
The CNC will manage the tool change.

2.

OPERATING IN JOG MODE
Tool control

FAGOR 

FAGOR AUTOMATION

CNC 8055
CNC 8055i

·MC· OPTION
SOFT: V02.2X

Tool information in machining centers.

This position does not exist on machining centers with tool changer arm; therefore, it will display the value of the variable: NXTTOOL.

The NXTTOOL variable sets the number of the next tool. This tool is the one that is selected but waiting to be activated by the execution of M06.

General machine parameter TOFFM06 (P28) indicates whether the machine is a machining center or not. If g.m.p. If TOFFM06 (P28) = YES, instead of displaying the tool change point, the CNC will display the value of the NXTTOOL variable.

2.

OPERATING IN JOG MODE
Tool control

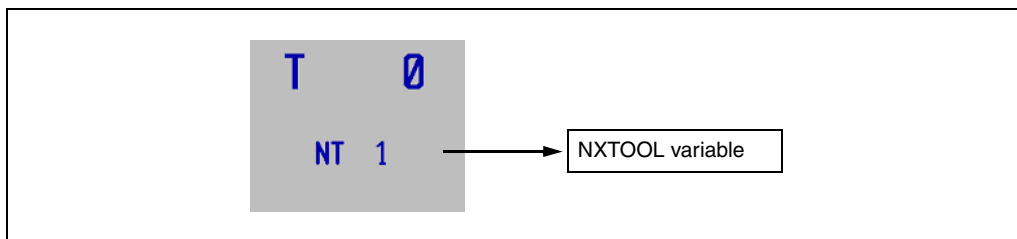

If the tool number and its associated offset are different, the CNC will also show the number of the associated tool offset.

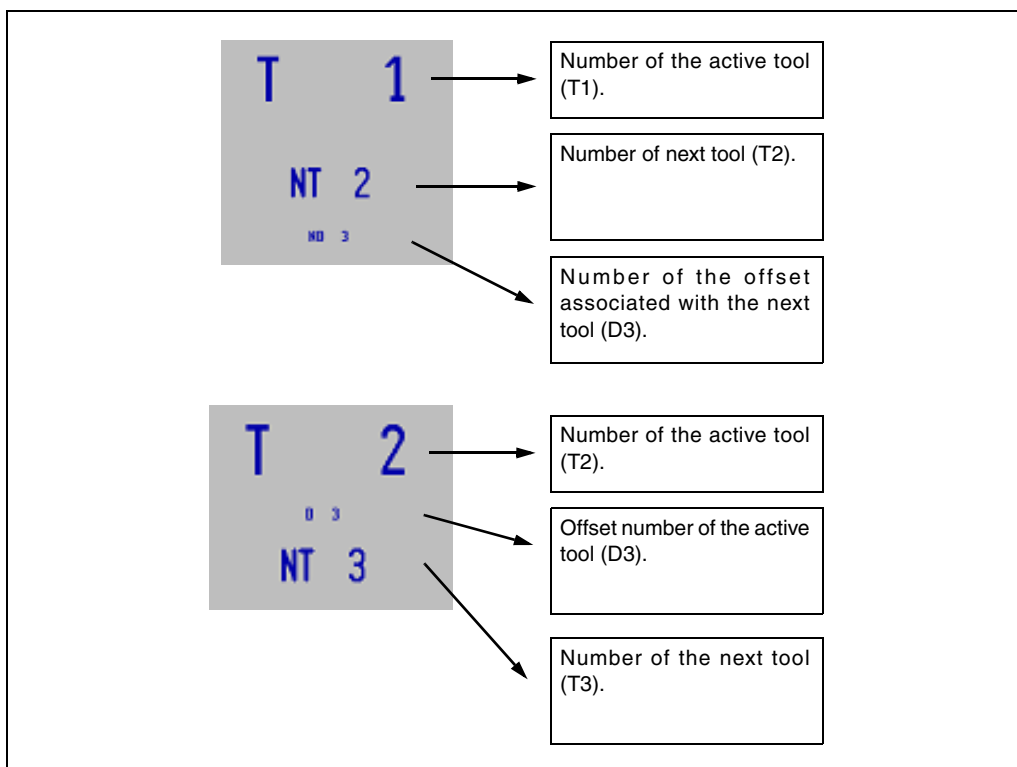

FAGOR AUTOMATION

CNC 8055
CNC 8055i

·MC· OPTION
SOFT: V02.2X

2.6.1 Tool change

Depending on the type of tool changer, the following options are possible:

- Machine with automatic tool changer.
- Machine with manual tool changer.

In either case, the CNC acts as follows:

- The CNC executes the subroutine associated with the tool change (general machine parameter P60 "TOOLSUB").
- The CNC sends to the PLC all the necessary information for it to manage the tool change.
- The CNC assumes the new tool values (offsets, geometry, etc).

Example of how to manage a manual tool changer.

- Subroutine 55 is defined as the subroutine associated with the tools.

General machine parameter P60 "TOOLSUB" = 55.

The subroutine associated with the tools may contain the following information:

```
(SUB 55)
(P100 = NBTOOL)
; Assigns the requested tool number to P100.
(P101 = MS3)
; If spindle counterclockwise P102=1.
G0 G53... XP?? YP?? ZP??
; Movement to the tool change point.
M5
; Spindle stop.
(MSG "SELECT T?P100 AND PRESS START")
; Message to select the tool change.
M0
; Stop the program stop and wait for START to be pressed.
(MSG "")
; Deletes previous message.
(IF P102 EQ 1 GOTO N10)
; Restores the spindle turning direction.
(IF P101 EQ 0 RET)
M3
(RET)
N10 M4
(RET)
```

- The tool is selected after executing the subroutine.
General machine parameter P71 "TAFTERS" = YES.
- The movement to the change point only takes place when executing an operation or cycle of the MC mode.

When a cycle has been selected (CYCEXE other than 0)

The program is being executed (OPMODA bit 0 = 1).

- Once the subroutine is completed, the CNC executes function T??, sends to the PLC all the necessary information for it to manage the tool change and assumes the new tool values (offsets, geometry, etc.).

2.

OPERATING IN JOG MODE
Tool control

FAGOR 

FAGOR AUTOMATION

CNC 8055
CNC 8055i

·MC· OPTION
SOFT: V02.2X

Managing a machining center.

When having a machining center, general machine parameter "TOFFM06 (P28) = Yes", the CNC acts as follows:

If the execution of an operation or cycle involves a tool change, the CNC:

- Selects the desired tool in the magazine.
- Executes the subroutine associated with the tool (general machine parameter "TOOLSUB (P60)").
- Executes function M06 to make the tool change.

When selecting a new tool in jog mode or working in M mode, the CNC only selects the tool in the magazine and executes the associated subroutine. The user must execute function M06, either by programming a block in ISO mode or setting the PLC so the M06 is executed when pressing a particular key.

The next example uses the [O4] key: DFU B2 R562 = CNCEX1 (M06, M1).



In machining centers, the subroutine associated with the tool must not have the M06 function.

2.**OPERATING IN JOG MODE**

Tool control



FAGOR AUTOMATION

**CNC 8055
CNC 8055i**-MC- OPTION
SOFT: V02.2X

2.6.2 Variable tool change point

If the manufacturer so wishes, he can let the user define the tool change point every time. Obviously, this feature depends on the type of machine and type of tool changer.

This feature may be used to change the tool next to the part, thus avoiding movements to a tool change point located far away from it.

To do this:

- Define the text 47 of program 999997 so the CNC requests the X, Y, Z coordinates of the tool change point.

For example: `;47 $CHANGE POSITION`

These coordinates must be referred to machine zero point, so the zero offsets do not affect the tool change point. Therefore, the CNC can show, next to the X, Y, Z coordinates and in small characters, the coordinates of the axes referred to machine reference zero.

- Text 33 of program 999997 must be defined so the CNC shows the coordinates of the axes referred to machine reference zero.

For example: `;33 $MACHINE ZERO`

Since the operator can change the tool change point at any time, the subroutine associated with the tools must consider those values. Arithmetic parameters P290, P291 and P292 contain the values set by the operator as tool change position in X, Y and Z respectively.

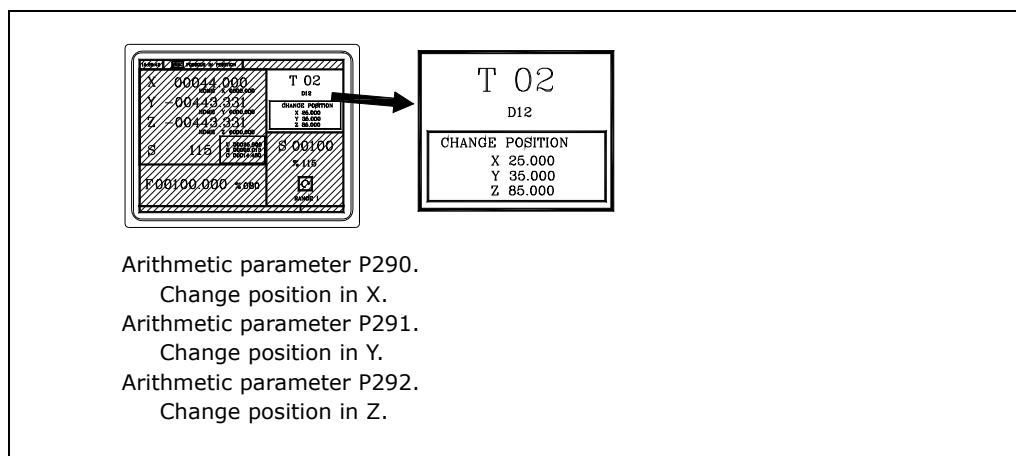

In subroutine 55 of the previous section, the line setting the movement to the tool change point must be modified:

Where it says:

`G0 G53 XP??? YP??? ZP??? ; Movement to the tool change point.`

It must say:

`G0 G53 XP290 YP291 ZP292 ;User-defined movement to the change point.`

Define the coordinates of the tool change point (X, Y, Z)

1. Press the [T] key to select the «T» field.
2. Then press the [X], [Y] or [Z] key of the desired axis or the [←] [→] [↑] [↓] keys.
3. After placing the cursor on the coordinates of the axis to be defined, define the desired values.

After placing the cursor on the coordinates of the axes to be defined, the value is entered in one of the following ways.

- Entering the value manually. Key in the desired value and press [ENTER].
- Assign the current machine position.

Jog the axis with the handwheel or the JOG keys up to the desired point. Press [RECALL] so the selected data assumes the value shown in the top right window and press [ENTER].

The top right window shows the tool position at all times.

2.

2.7 Tool calibration



This mode may be used to define the tools and calibrate them. The tools may be calibrated with or without using a probe.

This mode is also available while executing a program and during tool inspection.

The calibration mode can have three editing levels. The second and third levels will only be available when using a table-top probe installed on the machine.



Each level has its own screen and the main window of the cycle indicates, with tabs, the available levels and which one is selected. To change levels, use the [LEVEL CYCLE] key or the [page up] and [page down] keys to scroll up and down through the various levels.

What can be done in tool calibration mode

The data that may be modified from the calibration cycles depend on when this mode is accessed. The following limitations must be borne in mind when accessing the tool calibration mode with a program in execution or from tool inspection.

Without a program in execution nor in tool inspection.

When editing the active tool, it is possible:

- Modify all the data.
- Change the active tool (T ?? + [START]).

When NOT editing the active tool, it is possible:

- Modify all the data except the part dimensions.
- Change the active tool (T ?? + [START]).

Program in execution or interrupted.

When editing the active tool, it is possible:

- To modify the I and K data.
- Select another tool (T?? + [RECALL]) and modify the I and K data.

When NOT editing the active tool, it is possible:

- To modify the I, K and D data.
- Select another tool (T?? + [RECALL]) and modify the I, K and D data.

Program in tool inspection.

When editing the active tool, it is possible:

- To modify the I and K data.
- Select another tool (T?? + [RECALL]) and modify the I and K data.
- Change the active tool (T ?? + [START]).

When NOT editing the active tool, it is possible:

- To modify the I, K and D data.
- Select another tool (T?? + [RECALL]) and modify the I, K and D data.
- Change the active tool (T ?? + [START]).

2.

OPERATING IN JOG MODE
Tool calibration



FAGOR AUTOMATION

CNC 8055
CNC 8055i

·MC· OPTION
SOFT: V02.2X

2.7.1 Define the tool in the tool table (level 1)

When accessing this level, the CNC shows the following screen.

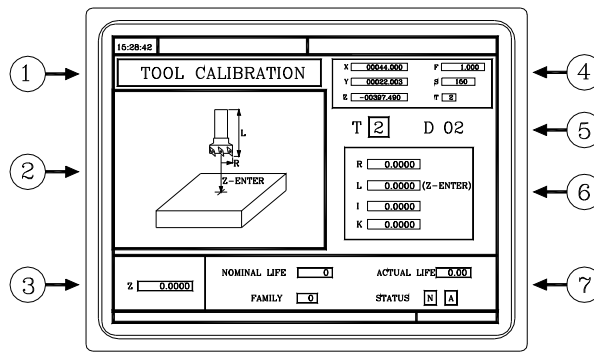

1. Indicating the selected work mode: "Tool calibration".
2. Graphic assistance for tool calibration.
3. Window for tool calibration.
4. Current machine status.
Real X Y Z coordinates, real axis feedrate F, real spindle speed S and currently selected tool T.
5. Tool number and associated offset.
6. Length and offset values defined in the tool offset table for this tool.
7. Nominal life, real life, family and status of the tool defined in the tool table.

Define the tool data

Proceed as follows to define a tool in the tool table:

Select the number of the tool to be defined.

1. Press the [T] key to select the "T" field.
2. Key in the desired tool number and press [RECALL].

If the tool is defined, the CNC will show the values stored in the table. If the tool is not defined, the CNC assigns an offset with the same number to it and all the data is reset to 0.

Select the number of the offset tool to be associated with this tool.

1. The "D" field must be selected. If it is not, use the [←] [→] [↑] [↓] keys.
2. Key in the desired offset number to be associated with the tool and press [ENTER].

Define the tool dimensions.

The data for the tool is the following.

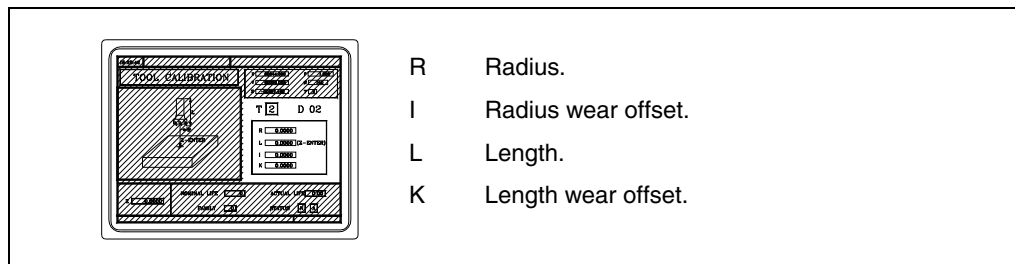

Even if the tool length (L) is known, it is recommended to measure it. See ["2.7.2 Tool calibration without a probe \(level 1\)"](#) on page 57.

Once the measurement has been completed, the CNC update the L and K fields. The CNC assumes (R+I) is the real radius and (L+K) ass the real length of the tool.

To define these values, select the corresponding field with the [←] [→] [↑] [↓] keys, key in the desired value and press [ENTER].

2.

OPERATING IN JOG MODE
Tool calibration

FAGOR

FAGOR AUTOMATION

CNC 8055
CNC 8055i

-MC- OPTION
SOFT: V02.2X

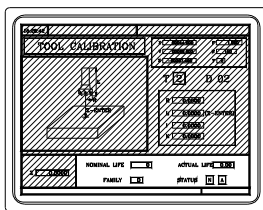
Define the rest of the data related to the tool

Nominal life.

Real (actual) life.

Family code.

Tool status.

Nominal life.

Machining time (in minutes) or number of operations that the tool may carry out.

Real (actual) life.

Machining time or number of operation the tool has carried out.

Family code.

It is used with an automatic tool changer.

0 ... 199 normal tools.

200 ... 255 special tools.

When requesting a new worn-out tool ("real life" greater than "nominal life"), the CNC will select the next tool of the same family, instead.

Tool status.

They are 2 fields for internal CNC data. They cannot be modified.

N = Normal (family 0-199).

S = Special (family 200-255).

A = Available

E = Expired ("real life" greater than "nominal life").

R = Rejected by the PLC.

To define these values, select the corresponding field with the [←] [→] [↑] [↓] keys, key in the desired value and press [ENTER].

2.

OPERATING IN JOG MODE
 Tool calibration



FAGOR AUTOMATION

CNC 8055
CNC 8055i

·MC· OPTION
 SOFT: V02.2X

2.7.2 Tool calibration without a probe (level 1)

Before measuring the tool, it must be defined in the tool table. See "2.7.1 Define the tool in the tool table (level 1)" on page 55.

There are 2 ways to calibrate a tool.

- When having a tool setting table.
Use the window that shows the tool dimensions to define that data.
- When not having any measuring device.
The measurements will be taken with the CNC. Use the window for tool calibration.

Define the tool length or modify the length offsets

This window shows the dimensions assigned to the selected tool.

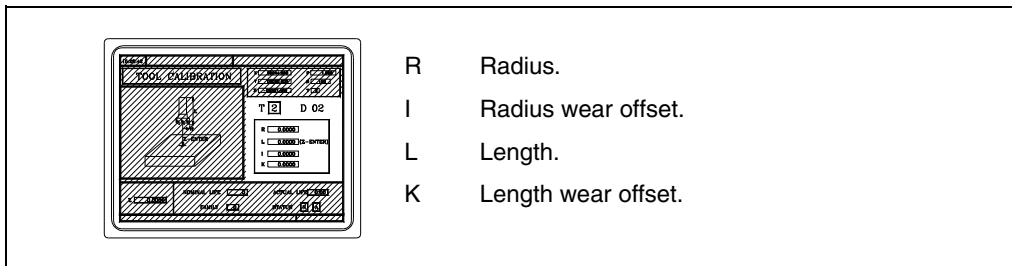

- R Radius.
- I Radius wear offset.
- L Length.
- K Length wear offset.

The R and L data indicate the tool dimensions, radius and length. I and K indicate the offset the CNC must apply to compensate for tool wear.

The CNC adds the value of the "I" offset to the radius (R) and the value of the "K" offset to the length (L) to calculate the real dimensions (R+I, L+K) that must be used.

- Every time the radius or length value is defined, the CNC sets the "I" and "K" fields to 0 respectively.
- The "I" and "K" data are accumulative. In other words, if the "I" has a value of 0.20 and the value of 0.05 is entered, the CNC assigns the value of 0.25 (0,20+0,05) to the "I" field.
- If one sets I=0 or K=0, they are both reset to 0.

To change one of these values, select the corresponding field, key in the desired value and press [ENTER].

2.

OPERATING IN JOG MODE
Tool calibration

FAGOR 

FAGOR AUTOMATION

CNC 8055
CNC 8055i

-MC- OPTION
SOFT: V02.2X

Tool calibration

The right window shows the tool dimensions and the lower left window shows the necessary data to calibrate it.

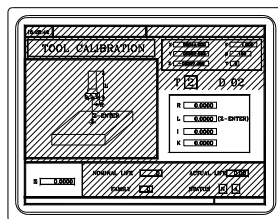

To access the calibration window, (lower left window) and, thus calibrate the tool, the tool must be selected on the machine. If it is not, press the [T] key, key in the desired number of the tool to be calibrated and press [START].

Select the lower left window with the [←] [→] [↑] [↓] keys Enter the Z coordinate of the part to be used in the calibration and press [ENTER].

Tool calibration (only measuring the length).

1. Approach the tool to the part and touch it with it.
2. Then, press the keystroke sequence [Z] [ENTER].

The tool has been calibrated. The CNC assigns the corresponding length (L) to it and resets the K offset value to 0. The tool radius (R) must be entered manually.

To calibrate another tool:

1. Select it on the machine.
2. Approach the tool to the part and touch it with it.
3. Then, press the keystroke sequence [Z] [ENTER].

Modifying the tool data while executing a program

It is possible to modifying the tool values (dimensions and geometry) without interrupting the execution of a program.



To do that, press the tool calibration key. The CNC will show the tool calibration screen with all the data for the active tool and it will allow modifying its data or of any other tool.

To exit this screen, press [ESC].

2.

OPERATING IN JOG MODE
Tool calibration



FAGOR AUTOMATION

CNC 8055
CNC 8055i

·MC· OPTION
SOFT: V02.2X

2.7.3 Tool calibration with a probe (level 2)

This calibration level requires the purchase of the right software options purchased and the use of a table-top probe.

When accessing this level, the CNC shows the following screen.

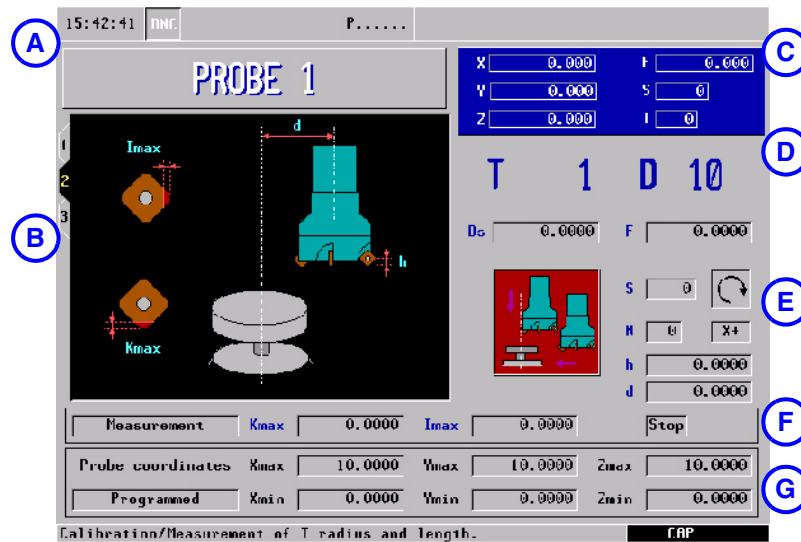

- A. Indicating the selected work mode.
- B. Graphic assistance for tool calibration.
- C. Current machine status.
- D. Tool number and associated offset.
- E. Calibration data.
- F. Type of operation and wear values.
- G. Probe position.

This level may be saved as part of a part-program using the [P.PROG] key or executed using the [START] key.

Defining the cycle data

The following data must be defined. Not all the data will always be available; the cycle will show the necessary data according to the chosen operation.

- Safety distance (Ds) for probe approach.
- Probing feedrate (F).
- Type of calibration or measurement.

The cycle allows calibrating or measuring the following dimensions; only the tool length along its shaft or on its tip, only the radius or the length and the radius.

- Speed (S) and turning direction of the tool. Select the turning direction opposite to the cutting direction.
- Number of cutting edges (N) to be measured.
- The probe side to be used (X+ X- Y+ Y-). Only when calibrating or measuring the radius.
- The distance from the tool shaft to the probing point (d). Only when calibrating or measuring the length at one end.
- Distance referred to the theoretical tool tip being probed (h). This parameter may be very useful on tools with cutters whose bottom is not horizontal.

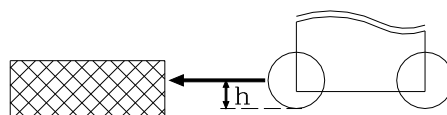

2.

OPERATING IN JOG MODE
Tool calibration



FAGOR AUTOMATION

CNC 8055
CNC 8055i

-MC- OPTION
SOFT: V02.2X

Type of operation.

The cycle allows doing a measurement or a calibration. To select the desired operation, position the cursor on the "Measurement / Calibration" field and press the two-color key. To take a measurement, define the following data.

Kmax	Maximum length wear allowed.
Imax	Maximum radius wear allowed.
Stop	Cycle behavior when exceeding the maximum wear allowed. Use the two-color key to select one of them.
Chg	

The "Stop" option interrupts the execution for the user to select another tool. With the "Chg" option, the cycle replaces the tool with another one of the same family.

Measuring is only available when purchasing the software option: "Tool life monitoring".

Probe position.

In this zone, one must indicate whether the cycle assumes the probe position defined in the machine parameters or the position defined in this zone. To select one of them, use the cursor to select the "Machine parameters / Programmable parameters" field and press the two-color key.

2.

OPERATING IN JOG MODE
Tool calibration



FAGOR AUTOMATION

CNC 8055
CNC 8055i

·MC· OPTION
SOFT: V02.2X

2.7.4 Part centering with / without a probe (level 3)

Part centering with / without a probe is in level 3 of the tool calibration mode.

Use the following icons to access the screen for part centering with or without a probe.



Part centering with a probe.



Part centering without a probe.



If the tabletop probe is not configured or probe cycles have been hidden (bit 1 of the g.m.p. COCYF1=1), the manual part centering will appear in level 2 of the tool calibration mode. In this case, part centering with a probe will not be displayed.

PART CENTERING WITH A PROBE

This calibration level requires the purchase of the right software options purchased and the use of a table-top probe.

Using a digital probe, this cycle calculates the real center coordinates, surface coordinate and inclination angle of a rectangular part or the real center and surface coordinates of a circular part.

Rectangular or circular part centering with a probe.

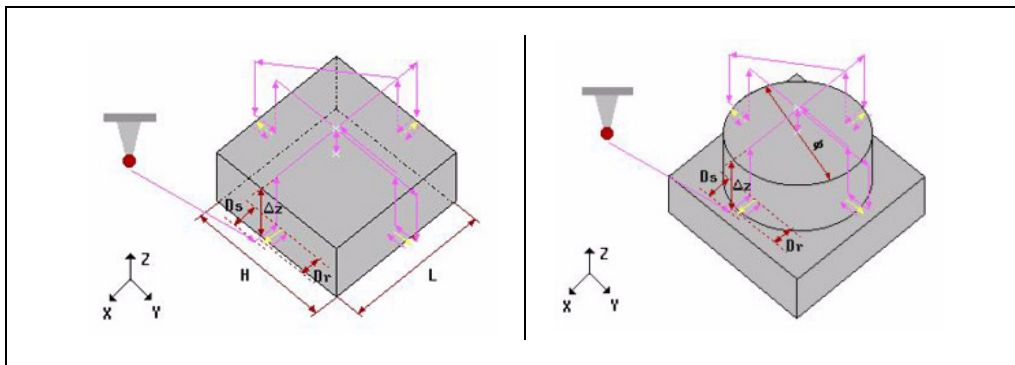

Data to be entered



Icon for selecting the axis and the direction (X+, X-, Y+, Y-) of the first probing movement.



Icon to select part surface measuring.



Icon to select the type of part to be centered (rectangular or circular).

- L, H:** Part lengths (length and width if rectangular, diameter if circular).
- ΔZ :** Distance for the probe to go up in Z for probing movements over the part.
- Ds:** Part approaching distance in part searching probing movements. If not programmed, it takes the approach distance left by the operator.
- Dr:** Withdrawal distance, after the part searching probing movement for measuring.
- X:** X coordinate of the probe position where the first probing move will start. If not programmed, it will assume the current X position of the probe.
- Y:** Y coordinate of the probe position where the first probing move will start. If not programmed, it will assume the current Y position of the probe.
- Z:** Z coordinate of the probe position where the first probing move will start. If not programmed, it will assume the current Z position of the probe.

2.

- T:** Probe's tool number. If not programmed or programmed with a 0 value, it generates the corresponding error message.
- D:** Tool offset number. If not programmed, it assumes the offset number assigned to T in the tool table.
- Fs:** Part searching probing feedrate. If not programmed or programmed with a 0 value, it generates the corresponding error message.
- F:** Probing feedrate for measuring. If not programmed or programmed with a 0 value, it generates the corresponding error message.
- Fa:** Probe positioning feedrate to the starting points of the part searching probing movements. If not programmed, it is done in rapid (G0).



Icon to preset the coordinates of a part reference point. Its possible values are:

- No preset.
- Preset at the center.
- Preset in each of the 4 corners if a rectangular part or in each of the 4 quadrants if a circular part.

ORGX: X coordinate of the preset value. If not programmed, it assumes 0.

ORGY: Y coordinate of the preset value. If not programmed, it assumes 0.

ORGZ: If part surface measuring has been selected, Z coordinate of the preset value. If not programmed, it assumes 0.



Icon to apply or not the measured coordinate (pattern) rotation. Only for rectangular parts.

MANUAL PART CENTERING WITHOUT A PROBE.

This cycle, without using a probe, minimizes the preparation time of a part calculating the real coordinates of the center and the inclination of the part.

To calculate the center of the part, the part must be touched on its sides.

Rectangular or circular part centering without a probe.

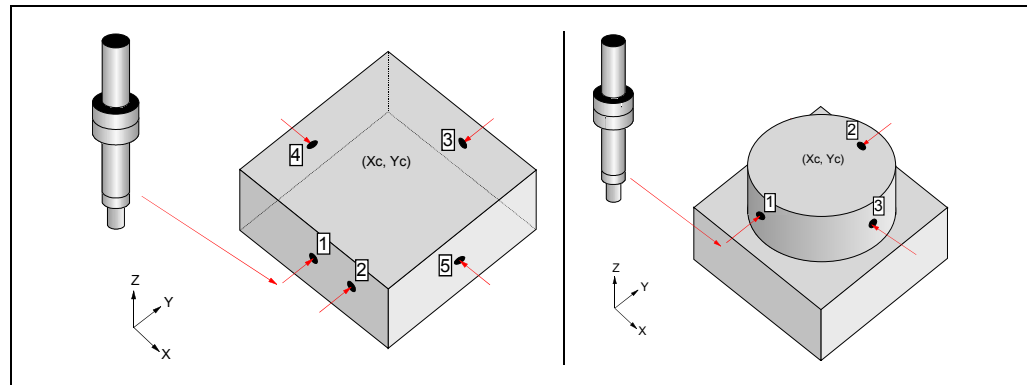

Considerations for the cycle

Going into manual part centering without a probe cancels G73 (pattern rotation).











When the focus is in "1 - RECALL" type box or in a box of the X or Y coordinate, it will change the color of its associated point in the drawing.

When selecting a circular part, it will be necessary to touch at 3 points; therefore, the screen will show 3 points. When selecting a rectangular part, the number of points to touch will depend on whether the centering is to be done on one or two axes and on whether the angle is to be calculated or not.

The X and Y coordinates of the various points can be edited at any time.

When the focus is in a "1 - RECALL" type box, the screen will show a help message.

Data to be entered

- 

 Icon to select the type of part to be centered (rectangular or circular).
- 

 Icon to choose between machine coordinates and part coordinates.
- 

 Icon to select axes (only for rectangular parts).
- 
 It may be used to define whether the part is to be centered in both axes or only in one.
- 
 Icon to preset the coordinates of a part reference point. Its possible values are:
 - No preset.
 - Preset at the center.
 - Preset in each of the 4 corners if a rectangular part or in each of the 4 quadrants if a circular part.
- 
- 
 Icon to calculate pattern rotation (only for rectangular parts).

- X** X coordinate of the preset value.
- Y** Y coordinate of the preset value.
- R** Radius of the tool used in part centering. This data can only be entered when presetting at one of the corners of a rectangular part.

If this value is not modified, the R data takes the radius value of the active tool. The R value is updated every time a new tool offset "D" is executed.

2.

OPERATING IN JOG MODE
Tool calibration



FAGOR AUTOMATION

CNC 8055
CNC 8055i

·MC· OPTION
SOFT: V02.2X

Operation

After selecting the type of part to be centered (rectangular or circular) proceed as follows:

1. Move the tool until touching the desired point of the part.
2. Place the focus in the box of the type "1 - RECALL" corresponding to the desired point and press [RECALL]. At this time, the coordinates of that point will be updated.

1 - RECALL	X1	<input type="text"/>
	Y1	<input type="text"/>
2 - RECALL	X2	<input type="text"/>
	Y2	<input type="text"/>
3 - RECALL	X3	<input type="text"/>
	Y3	<input type="text"/>
4 - RECALL	X4	<input type="text"/>
	Y4	<input type="text"/>
5 - RECALL	X5	<input type="text"/>
	Y5	<input type="text"/>
CALCULATE		

3. Repeat steps 1 and 2 for the rest of the points of the part.
4. After updating all the points, to calculate the center and the angle, place the focus on the "CALCULATE" button and press [ENTER]. The angle is only calculated when the part is rectangular and centering is done on both axes.
5. Once the whole process is finished, the CNC screen will show the center of the part and the angle if it has been selected.
If coordinate preset is active and the new part zero changes, the CNC will request confirmation.
6. If the new coordinate preset has been applied and it is working in part coordinates, the coordinates of the points will be updated with respect to the new reference point.

Arithmetic parameters modified by the cycle:

Once the part center and angle (only if necessary) have been calculated, the values obtained will be saved in the following general arithmetic parameters:

P296	Angle between the part and the X axis (α).
P298	Part center along the X axis (Xc).
P299	Part center along the Y axis (Yc).

In the ISO mode of the conversational mode, on the screen of the programming assistance for pattern rotation, when pressing [RECALL] while the focus is in the α field, this parameter will take the value calculated in the manual part centering cycle.



If the last cycle executed at the CNC using global parameter P296 was not the manual centering cycle, the α value will not be the one calculated in this cycle.



FAGOR AUTOMATION

CNC 8055
CNC 8055i

·MC· OPTION
SOFT: V02.2X

2.7.5 Tabletop probe calibration (level 4)

The new tabletop probe calibration cycle level 4 makes probe calibration easier. This reduces machine preparation time.

The tool used for calibration must properly calibrated in radius and length.

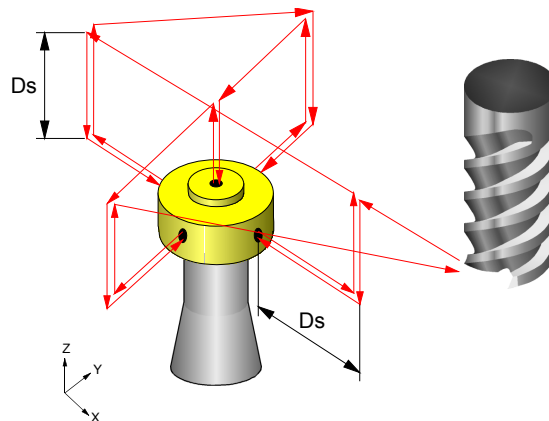

Data to be entered

[T] Tool number

It defines the number of the tool used to calibrate the probe. If not programmed or programmed with a 0 value, the CNC will display the corresponding error message.

[D] Tool offset number

It defines the tool offset number. If not programmed, it assumes the offset number assigned to T in the tool table.

[Ds] Approach distance

Probe approaching distance in each probing movement. If not programmed or programmed with a 0 value, the CNC will display the corresponding error message.

[Dr] Withdrawal distance

Distance the tool retracts after touching the probe to take the measurement. If not programmed or programmed with a 0 value, the CNC will display the corresponding error message.

[Fs] Searching feedrate

Probe searching feedrate. If not programmed or programmed with a 0 value, the CNC will display the corresponding error message.

[F] Measuring feedrate

Measuring feedrate. If not programmed or programmed with a 0 value, the CNC will display the corresponding error message.

Type of calibration

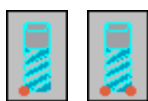

It indicates whether the calibration is simple or double.

- Single calibration: the calibration is carried out in the 4 quadrants of the probe with the spindle that holds the tool oriented at 0°.
- Double calibration: the calibration is carried out twice in the 4 quadrants of the probe, one with the spindle positioned at 0° and the other with the spindle positioned at 180°. This prevents tool eccentricity errors.

2.

OPERATING IN JOG MODE
Tool calibration

FAGOR 

FAGOR AUTOMATION

CNC 8055
CNC 8055i

-MC- OPTION
SOFT: V02.2X

Programming method for probe coordinates

It indicates whether the cycle assumes the probe position defined in the machine parameters or the position defined in the cycle. To select one of them, use the cursor to select the "Machine parameters / Programmable parameters" box and press the two-color key.

Machine parameters: The cycle assumes the probe position defined in the machine parameters.

Programmed parameters: The cycle assumes the probe position defined in the cycle (Xmax, Xmin, Ymax, Ymin, Zmax, Zmin).

[Xmax] Approximate X axis coordinate of the most positive side of the probe

Approximate coordinate of the most positive side of the probe, along the abscissa axis. If not programmed, it will assume the value of general machine parameter PRBXMAX (P41).

[Xmin] Approximate X axis coordinate of the least positive side of the probe

Approximate coordinate of the least positive side of the probe, along the abscissa axis. If not programmed, it will assume the value of general machine parameter PRBXMIN (P40).

[Ymax] Approximate Y axis coordinate of the most positive side of the probe

Approximate coordinate of the most positive side of the probe, along the ordinate axis. If not programmed, it will assume the value of general machine parameter PRBYMAX (P43).

[Ymin] Approximate Y axis coordinate of the least positive side of the probe

Approximate coordinate of the least positive side of the probe, along the ordinate axis. If not programmed, it will assume the value of general machine parameter PRBYMIN (P42).

[Zmax] Approximate Z axis coordinate of the most positive side of the probe

Approximate coordinate of the most positive side of the probe, along the Z axis. If not programmed, it will assume the value of general machine parameter PRBZMAX (P45).

[Zmin] Approximate Z axis coordinate of the least positive side of the probe

Approximate coordinate of the least positive side of the probe, along the Z axis. If not programmed, it will assume the value of general machine parameter PRBZMIN (P44).

Arithmetic parameters modified by the cycle

Once the cycle has been completed, the CNC will return the real values obtained after measurement, in the following global arithmetic parameters.

P295	Real coordinate of the least positive side of the probe, along the abscissa axis.
P296	Real coordinate of the most positive side of the probe, along the abscissa axis.
P297	Real coordinate of the least positive side of the probe, along the ordinate axis.
P298	Real coordinate of the most positive side of the probe, along the ordinate axis.
P299	Real coordinate of the measured probe side along the longitudinal axis.



FAGOR AUTOMATION

CNC 8055
CNC 8055i

.MC· OPTION
SOFT: V02.2X

2.8 Spindle control

The standard screen of the MC mode offers the following spindle data.

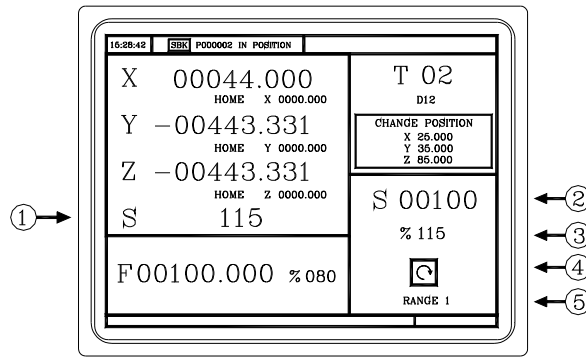

1. Real spindle speed in rpm.
2. Theoretical spindle speed in rpm.

To select another speed, press the [S] key. The CNC highlights the current value.

Enter the new value and press [START]. The CNC assumes that value and refreshes the real spindle speed.

The maximum spindle speed is saved in the MDISL variable. This variable is updated (refreshed) when programming function "G92 S" via ISO.

3. Percentage of the theoretical spindle speed being applied.

To modify the percentage (%), press the following keys.

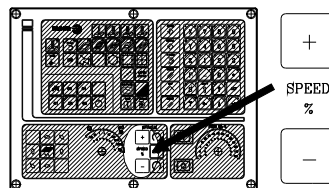

4. Spindle status:



Spindle clockwise,



Spindle counterclockwise



Spindle stopped.

To modify the spindle status, press the following keys:

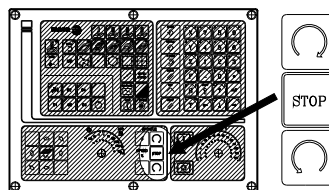

2.

OPERATING IN JOG MODE
Spindle control

FAGOR 

FAGOR AUTOMATION

CNC 8055
CNC 8055i

-MC- OPTION
SOFT: V02.2X

2.9 Controlling the external devices

With this CNC, it is possible to activate and deactivate, via keyboard, up to 6 external devices, for example, the coolant.

The machine manufacturer must use the PLC program to activate and deactivate the devices. The CNC will inform the PLC about the status of each key. The corresponding register bit will be set to 1 when the key is pressed and 0 when it is not pressed.

The register bit for each key is:

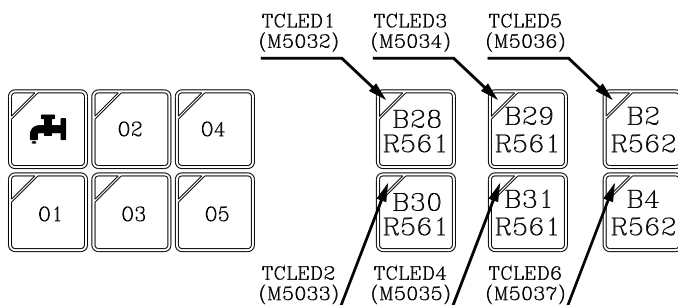

The status of the lamp of each key must be controlled by the machine manufacturer through the PLC program using the input variables TCLED* indicated in the figure.

Examples:

Coolant control:

DFU B28R561 = CPL TCLED1 = CPL O33

Tailstock control (O1). A number of conditions must be met for activating or deactivating the tailstock, such as spindle stopped, etc.

DFU B30R561 AND (Rest of conditions) = CPL TCLED2 = CPL O34

2.

OPERATING IN JOG MODE
Controlling the external devices



FAGOR AUTOMATION

CNC 8055
CNC 8055i

·MC· OPTION
SOFT: V02.2X

2.10 ISO management

Access to the MDI mode or the ISO mode.

The ISO key may be used to access the MDI mode or the ISO mode.

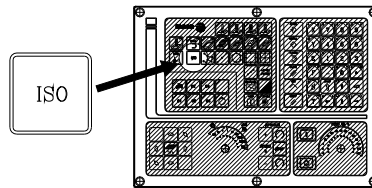

To access the MDI mode, the CNC must be in jog mode and the ISO key must be pressed. The CNC will show a window at the bottom of the standard (or special) screen.

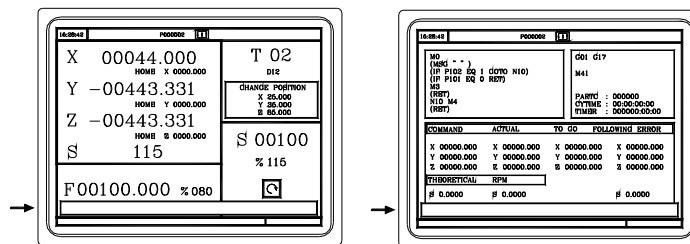

In this window, it is possible to edit a block in ISO code and then execute it, like in MDI in M mode.

Displaying the last 10 MDI instructions.

From the MDI mode, pressing the [UP ARROW] or [DOWN ARROW] key opens a window that shows the last 10 instructions that have been executed. This window resizes itself to fit the number of instructions that have been saved.

To execute or modify an MDI line that has been executed earlier, proceed as follows:

- Go into MDI mode.
- Press the [UP ARROW] or [DOWN ARROW] key to open the window that shows the last MDI instructions (up to 10).
- Use the [UP ARROW] or [DOWN ARROW] key to select the desired instruction.
 - Press [START] to execute the selected instruction.
 - Press [ENTER] to modify the selected instruction. Once the instruction has been modified, press [START] to execute it.

Considerations.

- An MDI instruction is saved only if it is correct and if it is not the same as the previous one on the list.
- The instructions are kept saved even after turning the unit off.

Generating an ISO-coded program

In the conversational mode of the CNC, it is possible to generate an ISO-coded program from an operation (cycle) or on a part-program. See "6.5 Graphic representation" on page 154.



OPERATING IN JOG MODE
ISO management



FAGOR AUTOMATION

CNC 8055
CNC 8055i

·MC· OPTION
SOFT: V02.2X

2.

OPERATING IN JOG MODE
ISO management



FAGOR AUTOMATION

CNC 8055
CNC 8055i

·MC· OPTION
SOFT: V02.2X

WORKING WITH OPERATIONS OR CYCLES

3

Use the following CNC keys to select the different machining operations or cycles.

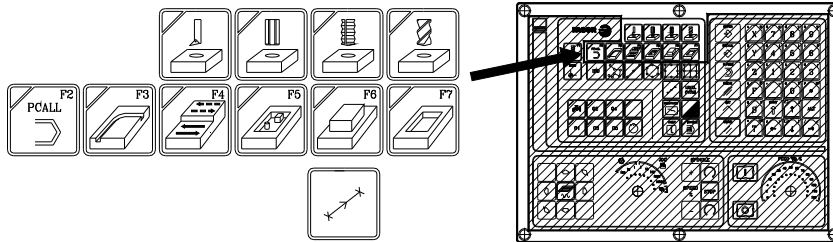

User cycles



When pressing [PCALL], the CNC shows all the user cycles defined by the machine manufacturer with the WGDRAW application.

The user cycle is edited like any other standard cycle of the MC mode. Once all the required data has been defined, the user can simulate or execute the cycle like any other standard cycle of the MC mode.

Cycles or operations of the CNC

When pressing any other key, the CNC selects the corresponding standard machining cycle, changes the display and turns on the lamp of the key that has been pressed (indicating the selected type).

Standard machining operations or cycles may be selected with each one of the following keys:



Boring.



Reaming.



Tapping.



Drilling and center punching.



Profile milling.



Surface milling and slot milling.



Pocket with profile (2D and 3D).



Rectangular and circular boss.



Rectangular and circular pocket.



Positioning.



When the machining operation or cycle has several levels, [LEVEL CYCLE] must be pressed to select the desired cycle level.



FAGOR AUTOMATION

CNC 8055
CNC 8055i

.MC· OPTION
SOFT: V02.2X

Some cycles may be carried out in the tool position or may be associated a multiple positioning so the cycle may be repeated in several locations. The positioning moves may be selected with each one of the following keys:



Multiple positioning in several locations.



Multiple positioning in a straight line.



Multiple positioning in an arc.



Multiple positioning in a rectangular pattern.



Multiple positioning in a grid pattern.

It is possible to combine ISO-coded blocks with standard and/or user cycles to create part-programs. Chapter "5 Saving programs" describes in detail how to do it and how to use those programs.

To de-select a cycle and return to the standard screen, press the key for the selected cycle (the one with the lamp on) or the [ESC] key.



When operating in conversational mode, do not use global parameters 150 through 299 (both included), because the operations or cycles can modify these parameters and cause the machine to malfunction.

3.

WORKING WITH OPERATIONS OR CYCLES



FAGOR AUTOMATION

CNC 8055
CNC 8055i

·MC· OPTION
SOFT: V02.2X

3.1 Operation editing mode

Once the operation has been selected, the CNC shows a screen like the following:

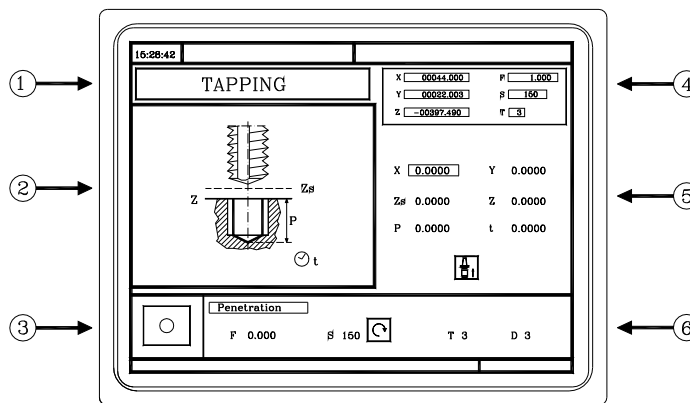

1. Name of the selected operation or work cycle.
2. Help graphics.
3. When it is a positioning operation, indicates its associated operation.
4. Current machine status. Coordinates and machining conditions.
5. Data defining the machining geometry.
6. Machining conditions for the operation.

The CNC will highlight an icon, a coordinate or one of the data defining the operation or cycle indicating that it has been selected. Use the following keys to select another icon, data or coordinate.



The CNC selects the previous one or the next one.



The CNC selects the first coordinate for that axis. Pressing that key again selects the next coordinate for that axis.



The CNC selects the corresponding roughing data. Pressing that key again selects the corresponding finishing data.



The CNC selects the "S" roughing data. Pressing that key again selects the "S" finishing data.

3.

WORKING WITH OPERATIONS OR CYCLES
Operation editing mode



FAGOR AUTOMATION

CNC 8055
CNC 8055i

-MC- OPTION
SOFT: V02.2X

3.1.1 Definition of machining conditions

Some operations keep the machining conditions throughout the execution (boring, reaming, etc.). Other operations use some machining conditions for roughing and others for finishing (pockets, bosses, etc.).

This section describes how to define all this data.

Selecting the roughing operation.

Place the cursor on the roughing checkbox, select or de-select the roughing operation pressing the [TWO-COLOR] key and press [ENTER]. When de-selecting the roughing, all its data will stay in gray.

The data for finishing "side stock" and "depth stock" is turned on/off using the roughing checkbox

Selecting the finishing operation.

Place the cursor on the finishing checkbox, select or de-select the finishing operation pressing the [TWO-COLOR] key and press [ENTER]. When de-selecting the finishing, all its data will stay in gray.

Axis feedrate (F).



Place the cursor over this data, key in the desired value and press [ENTER].

Spindle turning speed (S).



Place the cursor over this data, key in the desired value and press [ENTER].

Spindle turning direction



Place the cursor on this data and press the two-color key.

Machining tool (T).

Place the cursor over this data, key in the desired value and press [ENTER].



It is also possible to access the tool calibration mode to check or modify the data for the selected tool. To do that, place the cursor on the "T" and press the key associated with tool calibration.

Press [ESC] to quit the tool calibration mode and return to the cycle

Coolant.

There are two ways to turn the coolant on or off.



Place the cursor on this data and press the two-color key to change the icon.



Turns the coolant on. The CNC outputs the M8 function to the PLC.



Turns the coolant off. The CNC outputs the M9 function to the PLC.

Once the operation or the cycle is completed or the part-program it belongs to, the CNC outputs the M9 function to the PLC.

Roughing pass (Δ).



Place the cursor over this data, key in the desired value and press [ENTER].

Finishing stocks (δ , δz).



Place the cursor over this data, key in the desired value and press [ENTER].

3.

WORKING WITH OPERATIONS OR CYCLES
Operation editing mode



FAGOR AUTOMATION

CNC 8055
CNC 8055i

.MC. OPTION
SOFT: V02.2X

3.1.2 Safety plane

There are four work planes in all operations:

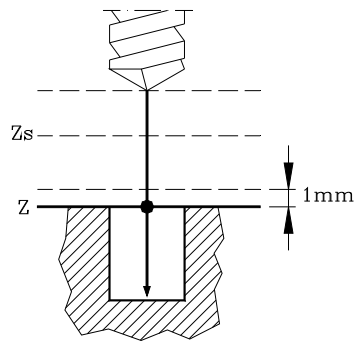

- Starting plane or position occupied by the tool when calling the cycle. It is not defined; the CNC sets it.
- Safety plane. It is used for the first approach and for withdrawing the tool after the machining operation. It is set with parameter Zs.
- Part approaching plane. The CNC calculates it, at 1 mm from the part surface.
- Part surface. It is set with parameter Z.

The tool moves in rapid (G00) to the safety plane (Zs), moves on in rapid to the approach plane (up to 1 mm off the part surface) and then moves at machining feedrate (G01) up to the part surface.

Approach to the part surface

The approach to the part surface depends on the current tool position.

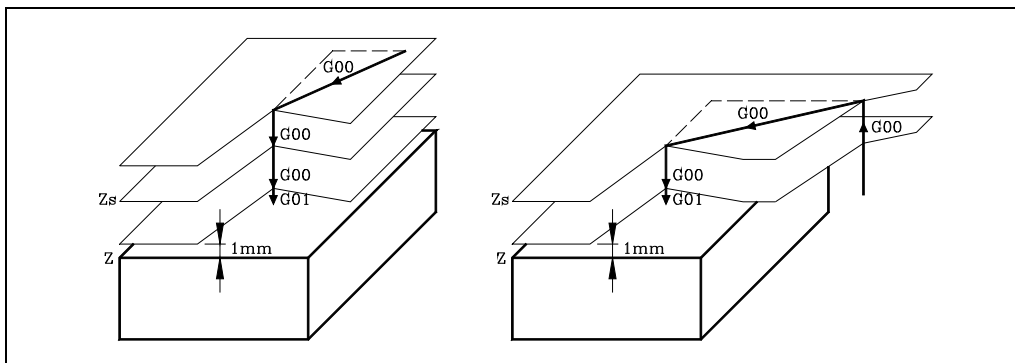

- If it is above the safety plane (left figure), it first moves in X, Y and then in Z.
- If it is below the safety plane (right figure), it first moves in Z to the safety plane, then in X, Y and finally in Z to the part surface.

3.1.3 Cycle level

All the cycles have several editing levels. Each level has its own screen and the main window of the cycle indicates, with tabs, the available levels and which one is selected.

3.

WORKING WITH OPERATIONS OR CYCLES
Operation editing mode

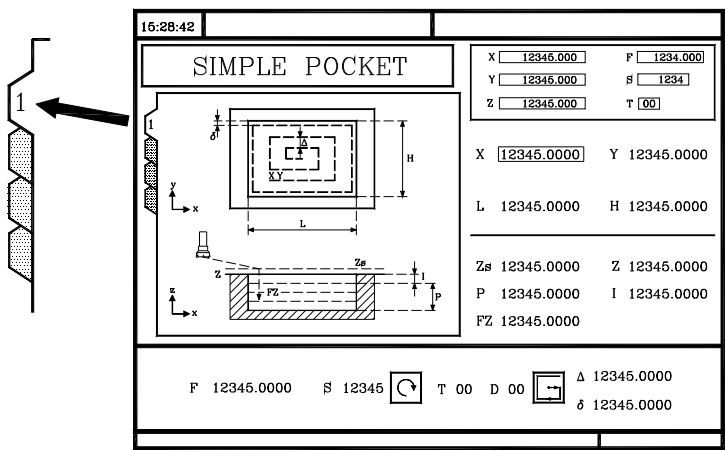

To change levels, use the [LEVEL CYCLE] key or the [page up] and [page down] keys to scroll up and down through the various levels.



FAGOR AUTOMATION

CNC 8055
CNC 8055i

·MC· OPTION
SOFT: V02.2X

3.2 Simulating and executing the operation

All the operations or cycles have 2 work modes; execution and editing.

- Press [ESC] to switch from editing mode to execution mode.
- Press [ESC] to switch from executing mode to editing mode.

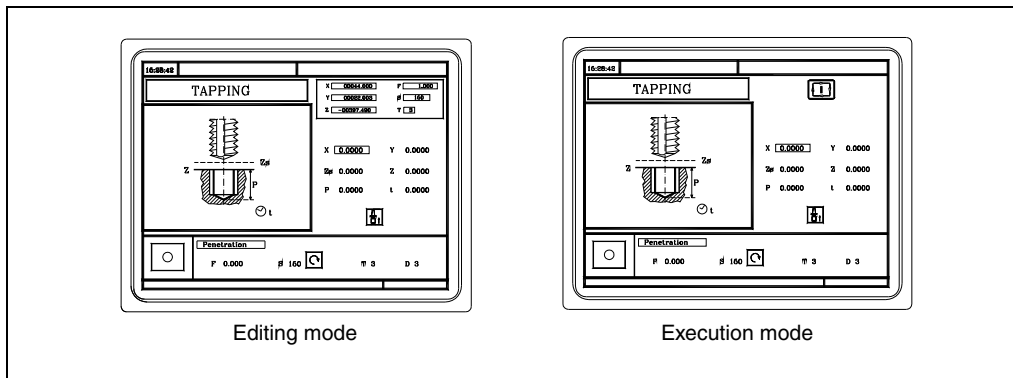
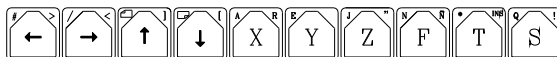

The operation or cycle may be simulated in either mode. To do that, press the [GRAPHICS] key.



To execute the operation or cycle, select the execution mode and press [START].

For further information on simulating and executing cycles, see the chapter ["6 Execution and simulation"](#).

3.

WORKING WITH OPERATIONS OR CYCLES
Simulating and executing the operation



FAGOR AUTOMATION

CNC 8055
CNC 8055i

-MC- OPTION
SOFT: V02.2X

3.2.1 Background cycle editing

It is possible to edit an operation or cycle while executing a program or part (background editing). The new operation edited may be saved as part of a part-program other than the one being executed.

The operation being edited in background cannot be executed or simulated, and the current position of the machine cannot be assigned to a coordinate.

Use the following keys to inspect or change a tool while editing in background.



Interrupts the execution and goes on editing in background.



To quit background editing.



To access tool inspection.

Pressing the [T] key without quitting background editing selects the T field of the operation or of the canned cycle being edited.



Background editing is not possible while executing an independent operation or cycle. It can only be done while executing a program or part.

3.

WORKING WITH OPERATIONS OR CYCLES
Simulating and executing the operation



FAGOR AUTOMATION

CNC 8055
CNC 8055i

·MC· OPTION
SOFT: V02.2X

3.3 Profile milling operation



This key accesses the profile milling operation.

This cycle may be defined in two ways:

Level 1.

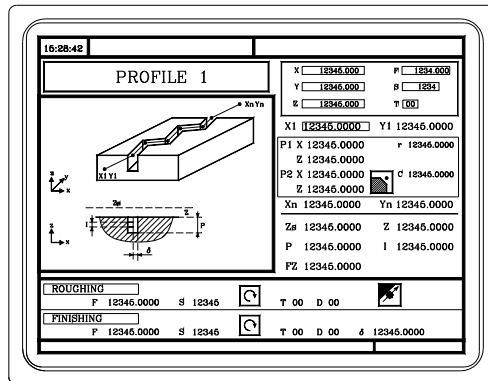

The following data must be defined:

- The starting point (X1, Y1), the intermediate points (P1 through P12), the last point (Xn, Yn) and the machining conditions in Z (Zs, Z, P, I, Fz).
- Also, in the area for roughing operation data, it must be defined whether the milling operation is carried out with or without tool compensation.

Level 2.

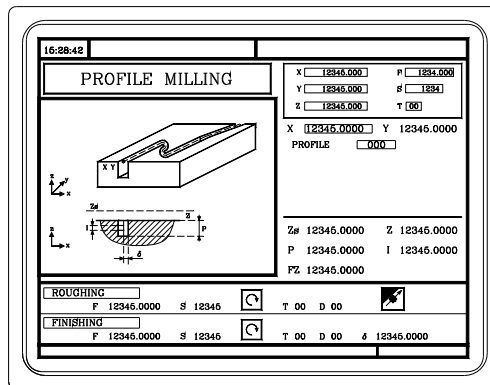

The following data must be defined:

- The starting point (X, Y), the "Profile program" number and the machining conditions in Z (Zs, Z, P, I, Fz).
- Also, in the area for roughing operation data, it must be defined whether the milling operation is carried out with or without tool compensation.

3.

WORKING WITH OPERATIONS OR CYCLES
Profile milling operation



FAGOR AUTOMATION

CNC 8055
CNC 8055i

-MC- OPTION
SOFT: V02.2X

3.3.1 Definition of data

Coordinates of the first and last points.

The coordinates are defined one by one. After placing the cursor on the coordinates of the axes to be defined, the value is entered in one of the following ways.

- Entering the value manually. Key in the desired value and press [ENTER].
- Assign the current machine position.

Jog the axis with the handwheel or the JOG keys up to the desired point. Press [RECALL] so the selected data assumes the value shown in the top right window and press [ENTER].

The top right window shows the tool position at all times.

Intermediate points (level 1).

The intermediate points are defined one by one. When not using the 12 definition points, the first unused point must be defined with the same coordinates as the last point of the profile.

The following must be defined for each point.



- The X, Y coordinates are defined one by one like the coordinates of the first and last points.
- Type of corner. To select the type of corner, place the cursor over this icon and press the two-color key.

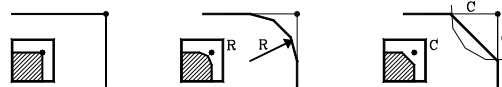

If a coordinate is left blank, the cycle will assume that it is the same as that of the previous one.

If defined...		The CNC assumes...
X1 25.323	Y1 26.557	Point: X1 25.323 Y1 26.557
X2	Y2 78.998	Point: X2 25.323 Y2 78.998
X3 67.441	Y3 83.231	Point: X3 67.441 Y3 83.231
X4	Y4	Point: X4 67.441 Y4 83.231
X5	Y5	There are no more points, it is a repetition of the previous point.

The coordinates of each point may also be defined incrementally. To do that, select the desired coordinate with the cursor and press the two-color key. Both coordinates of the selected point will be shown preceded by the "Δ" icon that indicates the incremental value with respect to the previous point.

Deleting all the points of a profile.

Once all the desired points have been programmed, they may all be erased at once. To delete all the programmed points at the same time, proceed as follows:

- Place the cursor on the text "DEF. PROFILE (max 12 points)" of the window where the points are edited.
- In the instant the cursor is placed in this position, the text changes to: "CLEAR - Delete all the points".
- At this moment, pressing [CLEAR] displays a window requesting confirmation to delete all the points: Press the [ENTER] to delete all the points or [ESC] not to delete them.

3.

WORKING WITH OPERATIONS OR CYCLES
Profile milling operation

FAGOR 

FAGOR AUTOMATION

CNC 8055
CNC 8055i

·MC· OPTION
SOFT: V02.2X

Machining conditions in Z (Zs, Z, P, I, Fz).

The machining conditions are defined one by one.

- The Zs and Z values are defined as the coordinates of the first and last points.
- To define the rest of the values (P, I, Fz), go to the corresponding window, key in the desired value and press [ENTER].

If the penetration step is programmed with a positive sign (I+), the cycle recalculates the step so all the penetrations are identical, this being equal to or less than the one programmed. If programmed with a negative sign (I-), the cycle is machined with the given pass (step) except the last pass that machines the rest.

Milling with or without tool radius compensation.



To select the type of corner, place the cursor over this icon and press the two-color key.



Without tool radius Compensation.



With left-hand tool radius compensation.



With right-hand tool radius compensation.

3.

WORKING WITH OPERATIONS OR CYCLES
Profile milling operation

FAGOR 

FAGOR AUTOMATION

CNC 8055
CNC 8055i

·MC· OPTION
SOFT: V02.2X

3.3.2 Profile definition (level 2)

Defining the profile program.

The profile program may be defined as follows.

- Key in the profile program number directly.
If the "profile program" is known, key in the program number and press [ENTER].
- Access the "profile programs" to select one of them.

Press the [↓] key. The canned cycle will show a window with the profile programs currently defined. Use the [↑] and [↓] keys to move around this window. After positioning the cursor on the desired program, press [ENTER].

To exit this window without selecting any program, use the [←] y [→] keys.



The profile programs can also be accessed in the "M" mode because the CNC saves them internally as P997xxx.

Example: Profile program 123 is internally saved as P997123.

When saving a part-program that contains a level-2 profile cycle into an external device, PC, floppy drive, etc. also save its associated profile program P997xxx.

Editing a new profile program.

To edit a new profile program, key in the program number (between 0 and 999) and press [RECALL]. The CNC will show the window for the profile editor (see operating manual).

After editing the profile, the CNC requests the comment to be associated with the "Profile program" that has been edited. Enter the desired comment and press [ENTER]. If no comment is desired, press [ESC].

Copying a profile program.

Press the [↓] key. The canned cycle will show the profile programs currently defined. Place the cursor on the profile program to be copied and press [P.PROG]. The CNC requests the number of the new profile and it allows changing its comment. If the number entered is the same as that of an existing profile, the CNC requests confirmation to replace it.

Modify an already existing "Profile program".

To modify a profile program, key in the program number and press [RECALL]. The CNC will show, in the window for the profile editor, the profile that is currently defined.

With this profile, the following actions are possible:

- Add new items at the end of the present profile.
- Modifying the data of any element.
- Modify or include chamfers, rounded corners, etc.
- Deleting elements of the profile.

Deleting an existing profile program.

Press the [↓] key. The canned cycle will show the profile programs currently defined. Place the cursor on the profile program to be deleted and press [CLEAR]. The CNC requests confirmation.

3.

WORKING WITH OPERATIONS OR CYCLES
Profile milling operation



FAGOR AUTOMATION

CNC 8055
CNC 8055i

·MC· OPTION
SOFT: V02.2X

3.4 Surface milling and slot milling operations



This key accesses the surface milling and slot milling operations.

Surface milling operation.

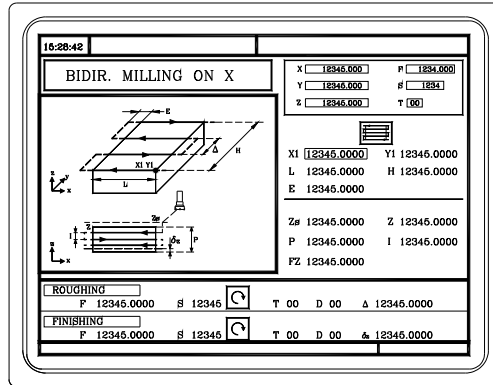

The following data must be defined:

- The type of surface milling, the starting point (X1, Y1), the dimensions of the surface milling (L, H, E, α) and the machining conditions in Z (Zs, Z, P, I, Fz).
- Also, you must define the milling pass (Δ) in the data area for the roughing operation and the finishing stock (δz) in the data area for the finishing operation.

Grooving operation.

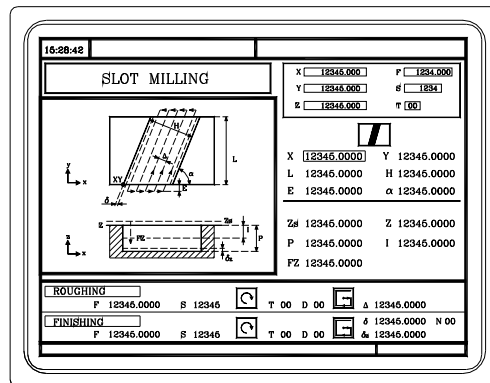

The following data must be defined:

- The type of slot milling, the starting point (X1, Y1), the dimensions of the slot (L, H, E, α) and the machining conditions in Z (Zs, Z, P, I, Fz).



- In the roughing area, define the milling pass (Δ) and the machining direction.
- In the finishing area, define the finishing stocks (δ and δz), the number of finishing passes and the machining direction.

3.

WORKING WITH OPERATIONS OR CYCLES
Surface milling and slot milling operations



FAGOR AUTOMATION

CNC 8055
CNC 8055i

-MC- OPTION
SOFT: V02.2X

3.4.1 Defining the surface milling data

Type of surface milling.

Type of surface milling.

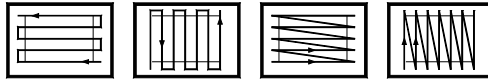

To select the type of surface milling, place the cursor over this icon and press the two-color key.

Coordinates of starting point (X1, Y1).

Define one of the corners of the surface to be milled (X1, Y1). The coordinates are defined one by one. After placing the cursor on the coordinates of the axes to be defined, the value is entered in one of the following ways.

- Entering the value manually. Key in the desired value and press [ENTER].
- Assign the current machine position.

Jog the axis with the handwheel or the JOG keys up to the desired point. Press [RECALL] so the selected data assumes the value shown in the top right window and press [ENTER].

The top right window shows the tool position at all times.

Surface to be milled (L, H, E, α).

After defining one of the corners (X1, Y1), define the length (L) and width (H) of the surface to be milled. The sign of the L and H indicates the orientation referred to the X1, Y1 point.

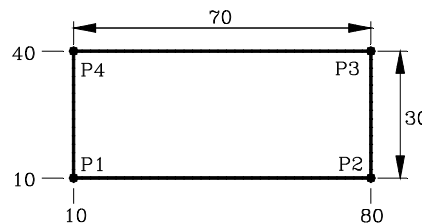

P1	X1=10	Y1=10
	L=70	H=30
P2	X1=80	Y1=10
	L=-70	H=30
P3	X1=80	Y1=40
	L=-70	H=-30
P4	X1=10	Y1=40
	L=70	H=-30

Once the surface to be milled has been defined, the icon shown at the bottom right (roughing and finishing area) may be used to select the corner to start milling the surface.

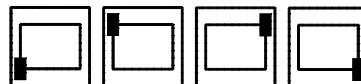

- The data E and α are defined one by one. Place the cursor in the corresponding window, key in the desired value and press [ENTER].

When programming parameter "E" with a value smaller than the tool radius, the CNC executes the surface milling with an "E" value equal to the tool radius.

Machining conditions in Z (Zs, Z, P, I, Fz).

The machining conditions are defined one by one.

- The Zs and Z values are defined as the coordinates of the first and last points.
- To define the rest of the values (P, I, Fz), go to the corresponding window, key in the desired value and press [ENTER].

If the penetration step is programmed with a positive sign (I+), the cycle recalculates the step so all the penetrations are identical, this being equal to or less than the one programmed. If programmed with a negative sign (I-), the cycle is machined with the given pass (step) except the last pass that machines the rest.

Milling pass (Δ) and finishing stock (δz).

These data are defined one by one. Place the cursor in the corresponding window, key in the desired value and press [ENTER].

3.

WORKING WITH OPERATIONS OR CYCLES
Surface milling and slot milling operations



FAGOR AUTOMATION

CNC 8055
CNC 8055i

.MC- OPTION
SOFT: V02.2X

3.4.2 Defining the grooving data

Type of grooving.

Type of grooving.



To select the type of grooving, place the cursor over this icon and press the two-color key.

Coordinates of the starting point.

The coordinates are defined one by one. After placing the cursor on the coordinates of the axes to be defined, the value is entered in one of the following ways.

- Entering the value manually. Key in the desired value and press [ENTER].
- Assign the current machine position.

Jog the axis with the handwheel or the JOG keys up to the desired point. Press [RECALL] so the selected data assumes the value shown in the top right window and press [ENTER].

The top right window shows the tool position at all times.

Dimensions of the slot (L , H , E , α).

These data are defined one by one. Place the cursor in the corresponding window, key in the desired value and press [ENTER].

When programming parameter "E" with a value smaller than the tool radius, the CNC executes the slot milling with an "E" value equal to the tool radius.

Machining conditions in Z (Z_s , Z , P , I , F_z).

The machining conditions are defined one by one.

- The Z_s and Z values are defined as the coordinates of the first and last points.
- To define the rest of the values (P , I , F_z), go to the corresponding window, key in the desired value and press [ENTER].

If the penetration step is programmed with a positive sign ($I+$), the cycle recalculates the step so all the penetrations are identical, this being equal to or less than the one programmed. If programmed with a negative sign ($I-$), the cycle is machined with the given pass (step) except the last pass that machines the rest.

Milling pass (Δ) and finishing stock (δz).

These data are defined one by one. Place the cursor in the corresponding window, key in the desired value and press [ENTER].

3.

WORKING WITH OPERATIONS OR CYCLES
Surface milling and slot milling operations

FAGOR 

FAGOR AUTOMATION

CNC 8055
CNC 8055i

-MC- OPTION
SOFT: V02.2X

Clockwise milling of the different types of slots .

3.

WORKING WITH OPERATIONS OR CYCLES
Surface milling and slot milling operations

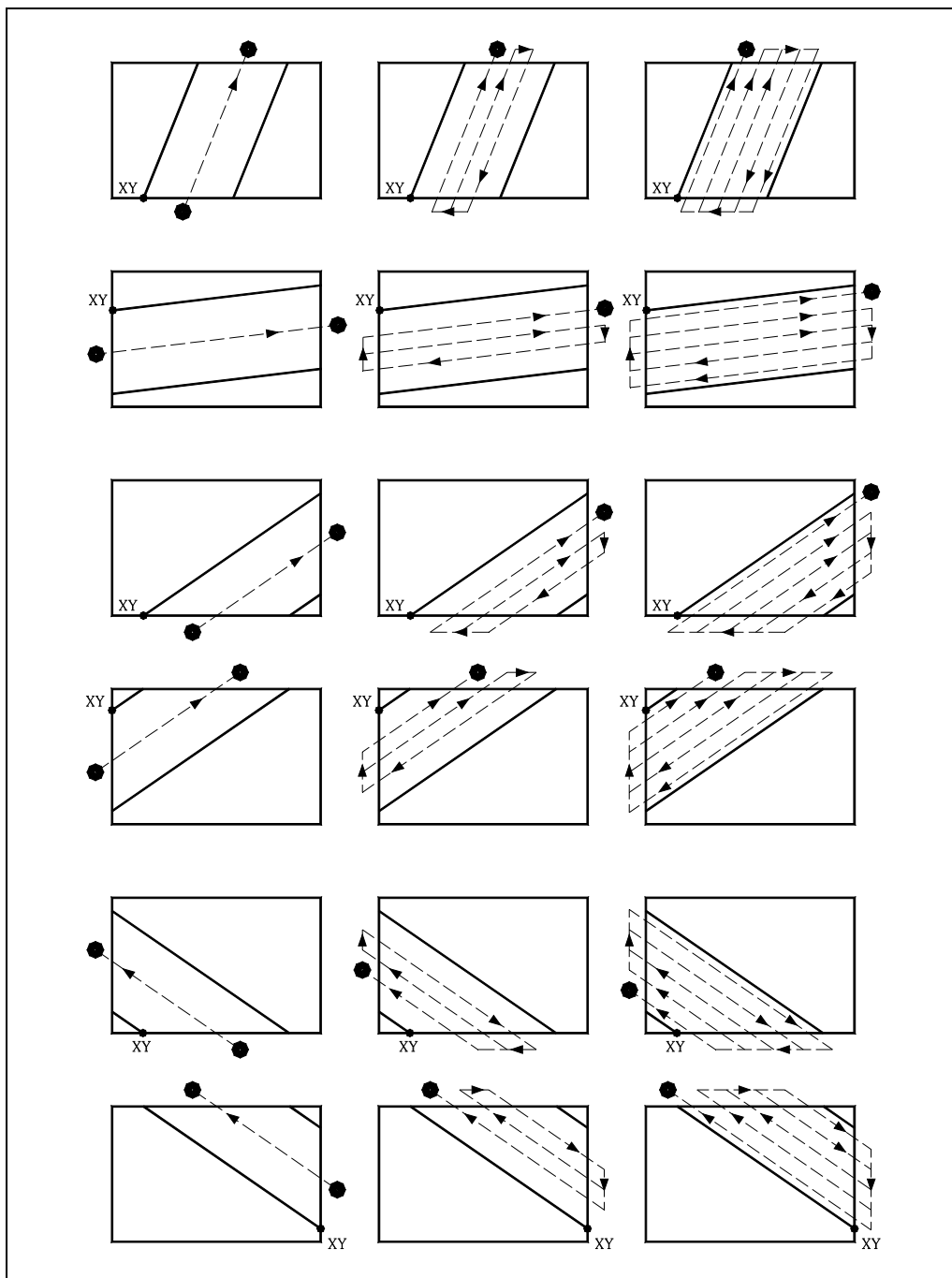

FAGOR AUTOMATION

CNC 8055
CNC 8055i

·MC· OPTION
SOFT: V02.2X

3.5 Pocket cycle with a profile



This key accesses the pocket-with-profile operation.

There are two types of pocket with profile; 2D and 3D.

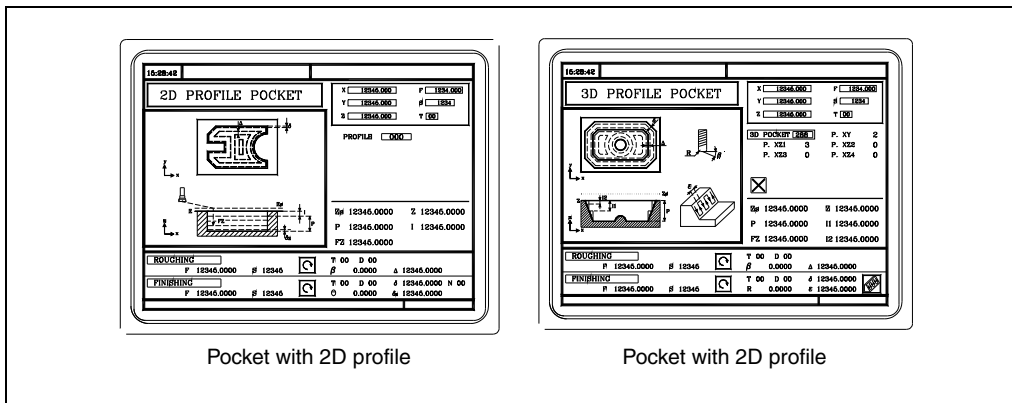

Pocket with 2D profile

Pocket with 2D profile

A pocket is composed by an external contour or profile (1) and a series of internal contours or profiles (2). These internal profiles are called islands.

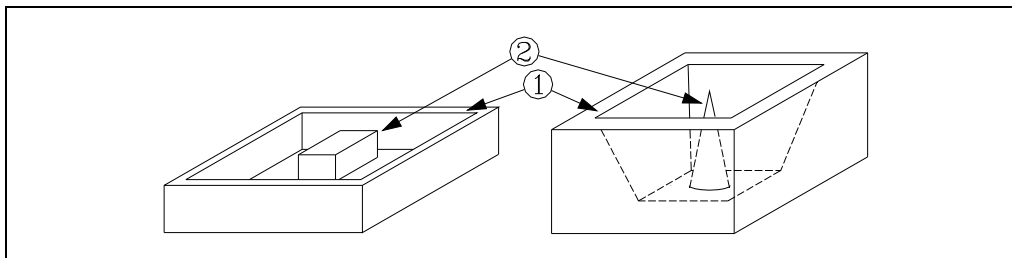

- In 2D pockets (top left figure), all the walls of the outside profile and of the islands are vertical.
- In 3D pockets (top right figure), one, several or all the walls of the outside pocket and/or of the islands are not vertical (up to a maximum of 4).

Programming 2D pockets with profile.

When defining the profile, one must indicate, besides the outside contour of the pocket, the contour or contours of the islands.

The machining in Z is defined with the following parameters:

- Zs Safety plane coordinate.
- Z Part surface coordinate.
- P Pocket depth.
- I Step in Z.
- Fz Penetrating feedrate in Z.

The following must be defined in the data area for the roughing operation:

- β The sideways penetration angle.
- Δ The milling pass.

The following must be defined in the data area for the finishing operation:

- θ The sideways penetration angle.
- δ Finishing stock on the side walls.
- δz Finishing stock at the bottom.
- N Number of finishing passes in Z.

3.

WORKING WITH OPERATIONS OR CYCLES
Pocket cycle with a profile



FAGOR AUTOMATION

CNC 8055
CNC 8055i

·MC· OPTION
SOFT: V02.2X

Programming 3D pockets with profile.

Pocket identification number (POCK. 3D).

Several 3D pockets are possible. The CNC associates to each 3D pocket all its data (surface profile, depth profile, machining conditions, etc.).

Surface profile or profile in the XY plane. Profile (P. XY).

One must indicate, besides the outside contour of the pocket, the contour or contours of the possible islands.

Depth profile for the first profile defined. Profile (P. Z1).

They usually correspond to the outside contour of the pocket.

Depth profile for the second profile defined. Profile (P. Z2).

They usually correspond to the contour of the first island defined.

Depth profile for the third profile defined. Profile (P. Z3).

They usually correspond to the contour of the second island defined.

Depth profile for the fourth profile defined. Profile (P. Z4).

They usually correspond to the contour of the third island defined.

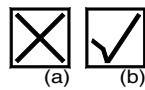

Once all the profiles have been defined, the configuration of the 3D pocket must be validated. To do that, place the cursor on the icon (a) and press [ENTER] to validate the pocket. The cycle will show the icon (b).

The machining in Z is defined with the following parameters:

- Zs Safety plane coordinate.
- Z Part surface coordinate.
- P Pocket depth.
- I1 Roughing step in Z.
- Fz Penetrating feedrate in Z.
- I2 Semi-finishing step in Z.

The following must be defined in the data area for the roughing operation:

- β The sideways penetration angle.
- Δ The milling pass.

The following must be defined in the data area for the finishing operation:

- R Tool tip radius.
- δ Finishing stock on the side walls.
- ε Finishing pass.



Direction of the finishing passes on the walls.



The pocket configuration program and the profile programs can also be accessed in the "M" mode because the CNC saves them internally as:

P995xxx - 3D pocket configuration.

P998xxx - The profiles of the XY plane, both in 2D and 3D pockets.

P996xxx - The depth profiles of the 3D pockets.

3.

WORKING WITH OPERATIONS OR CYCLES
Pocket cycle with a profile



FAGOR AUTOMATION

CNC 8055
CNC 8055i

·MC· OPTION
SOFT: V02.2X

3.5.1 Definition of data

Machining conditions in Z (Zs, Z).

To define the values (Zs and Z), after going to the corresponding window, the value is entered in one of the following ways.

- Entering the value manually. Key in the desired value and press [ENTER].
- Assign the current machine position.

Jog the axis with the handwheel or the JOG keys up to the desired point. Press [RECALL] so the selected data assumes the value shown in the top right window and press [ENTER].

The top right window shows the tool position at all times.

Machining conditions in Z (P, Fz, I, I1, I2).

The machining conditions are defined one by one.

- To define the values (P, Fz, I, I1, I2), go to the corresponding window, key in the desired value and press [ENTER].

If the penetration step is programmed with a positive sign (I+), the cycle recalculates the step so all the penetrations are identical, this being equal to or less than the one programmed. If programmed with a negative sign (I-), the cycle is machined with the given pass (step) except the last pass that machines the rest.

Milling pass (Δ) and finishing pass (ϵ).

Place the cursor in the corresponding window, roughing or finishing operation, key in the desired value and press [ENTER].

Sideways penetration angle (β , θ).

Place the cursor in the corresponding window, roughing or finishing operation, key in the desired value and press [ENTER].

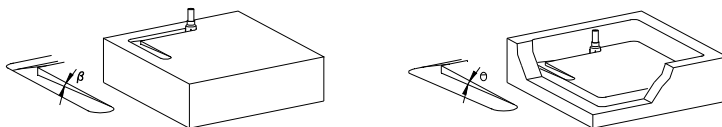

Finishing stock on the side walls (δ) and at the bottom (δz).

Place the cursor in the corresponding window, finishing operation, key in the desired value and press [ENTER].

Finishing tool tip radius (R).

Place the cursor in the corresponding window, finishing operation, key in the desired value and press [ENTER].

Direction of the finishing passes on the walls.



To select the direction of the finishing passes on the walls, place the cursor over this icon and press the two-color key.

3.

WORKING WITH OPERATIONS OR CYCLES

Pocket cycle with a profile

FAGOR 

FAGOR AUTOMATION

CNC 8055
CNC 8055i

-MC- OPTION
SOFT: V02.2X

3.5.2 Profile definition

Defining the profile program.

The profile program may be defined as follows.

- Key in the profile program number directly.
If the "profile program" is known, key in the program number and press [ENTER].
- Access the "profile programs" to select one of them.

Press the [↓] key. The canned cycle will show a window with the profile programs currently defined. There are 3 different directories, one for the pocket configuration profiles, another one for the profiles in the XY plane and another one for the depth profiles. Use the [↑] and [↓] keys to move around this window. After positioning the cursor on the desired program, press [ENTER].

To exit this window without selecting any program, use the [←] y [→] keys.



*The profile programs can also be accessed in the "M" mode because the CNC saves them internally as:
P995xxx - 3D pocket configuration.*

P998xxx - The profiles of the XY plane, both in 2D and 3D pockets.

P996xxx - The depth profiles of the 3D pockets.

When saving a part-program that contains a pocket-with-profile cycle into an external device, PC, floppy drive, etc. also save its associated profile programs.

Editing a new profile program.

To edit a new profile program, key in the program number (between 0 and 999) and press [RECALL]. The CNC will show the window for the profile editor (see operating manual).

After editing the profile, the CNC requests the comment to be associated with the "Profile program" that has been edited. Enter the desired comment and press [ENTER]. If no comment is desired, press [ESC].

Copying a profile program.

Press the [↓] key. The canned cycle will show the profile programs currently defined. Place the cursor on the profile program to be copied and press [P.PROG]. The CNC requests the number of the new profile and it allows changing its comment. If the number entered is the same as that of an existing profile, the CNC requests confirmation to replace it.

Modify an already existing "Profile program".

To modify a profile program, key in the program number and press [RECALL]. The CNC will show, in the window for the profile editor, the profile that is currently defined.

With this profile, the following actions are possible:

- Add new items at the end of the present profile.
- Modifying the data of any element.
- Modify or include chamfers, rounded corners, etc.
- Deleting elements of the profile.

Deleting an existing profile program.

Press the [↓] key. The canned cycle will show the profile programs currently defined. Place the cursor on the profile program to be deleted and press [CLEAR]. The CNC requests confirmation.

3.

WORKING WITH OPERATIONS OR CYCLES
Pocket cycle with a profile



FAGOR AUTOMATION

CNC 8055
CNC 8055i

·MC· OPTION
SOFT: V02.2X

3.5.3 Profile definition examples

Example of how to define a 2D profile without islands:

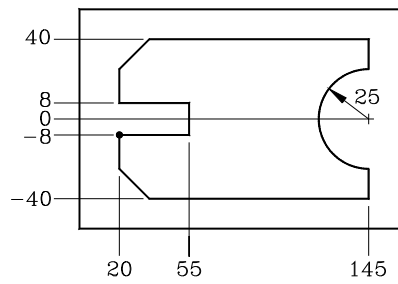
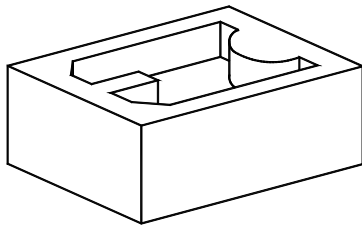

2D pocket.

Profile 1 [RECALL]

Configuration.

Abscissa axis: X Ordinate axis: Y

Autozoom: Yes

Validate

Profile.

Initial point	X 20	Y -8		Validate
Straight line	X 20	Y -40		Validate
Straight line	X 145	Y -40		Validate
Straight line	X 145	Y -25		Validate
Clockwise arc	Xf 145	Yf 25	R 25	Validate
Straight line	X 145	Y 40		Validate
Straight line	X 20	Y 40		Validate
Straight line	X 20	Y 8		Validate
Straight line	X 55	Y 8		Validate
Straight line	X 55	Y -8		Validate
Straight line	X 20	Y -8		Validate

Corners.

Lower left corner [ENTER] Chamfer 15 [ENTER]

Upper left corner [ENTER] Chamfer 15 [ENTER]

[ESC]

End.

Save profile.

3.

WORKING WITH OPERATIONS OR CYCLES
Pocket cycle with a profile



FAGOR AUTOMATION

CNC 8055
CNC 8055i

·MC· OPTION
SOFT: V02.2X

Example of how to define a 2D profile with islands:

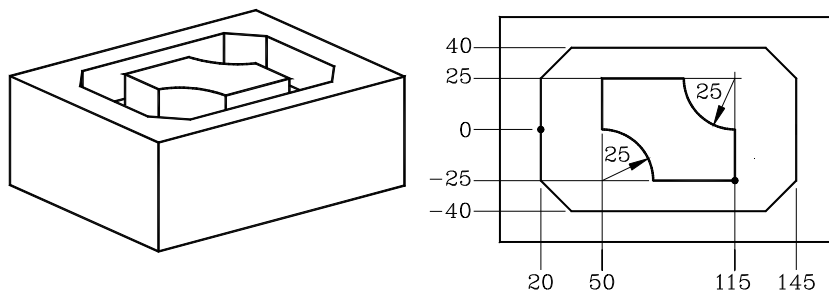

3.

WORKING WITH OPERATIONS OR CYCLES
Pocket cycle with a profile

2D pocket.

Profile 2 [RECALL]

Configuration.

Abscissa axis: X Ordinate axis: Y

Autozoom: Yes Validate

Profile (outside profile).

Initial point	X 20	Y 0	Validate
Straight line	X 20	Y -40	Validate
Straight line	X 145	Y -40	Validate
Straight line	X 145	Y 40	Validate
Straight line	X 20	Y 40	Validate
Straight line	X 20	Y 0	Validate

Corners.

Lower left corner	[ENTER]	Chamfer	15	[ENTER]
Lower right corner	[ENTER]	Chamfer	15	[ENTER]
Upper right corner	[ENTER]	Chamfer	15	[ENTER]
Upper left corner	[ENTER]	Chamfer	15	[ENTER]
				[ESC]

New profile (island).

Profile						
Initial point	X 115	Y -25	Validate			
Straight line	X 115	Y 0	Validate			
Clockwise arc	Xf 90	Yf 25	Xc 115	Yc 25	R 25	Validate
Straight line	X 50	Y 25	Validate			
Straight line	X 50	Y 0	Validate			
Clockwise arc	Xf 75	Yf -25	Xc 50	Yc -25	R 25	Validate
Straight line	X 115	Y -25	Validate			

End.

Save profile.



FAGOR AUTOMATION

CNC 8055
CNC 8055i

.MC- OPTION
SOFT: V02.2X

Example of how to define a 3D profile without islands:

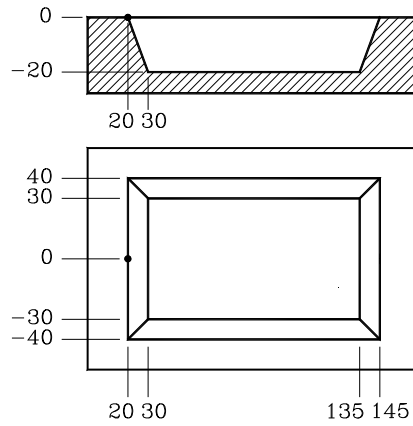
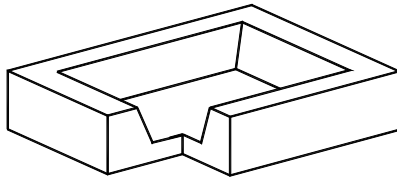

3D pocket = 1

Outside profile (P.XY).

P.XY= 3

[RECALL]

Configuration.

Abscissa axis: X

Ordinate axis: Y

Autozoom: Yes

Validate

Profile.

Initial point	X 20	Y 0	Validate
Straight line	X 20	Y -40	Validate
Straight line	X 145	Y -40	Validate
Straight line	X 145	Y 40	Validate
Straight line	X 20	Y 40	Validate
Straight line	X 20	Y 0	Validate

End.

Save profile.

Depth profile (P.Z1).

P.XY= 3

[RECALL]

Configuration.

Abscissa axis: X

Ordinate axis: Z

Autozoom: Yes

Validate

Profile.

Initial point	X 20	Z 0	Validate
Straight line	X 30	Z -20	Validate

End.

Save profile.

3.

WORKING WITH OPERATIONS OR CYCLES
Pocket cycle with a profile



FAGOR AUTOMATION

CNC 8055
CNC 8055i

-MC- OPTION
SOFT: V02.2X

Example of how to define a 3D profile with islands:

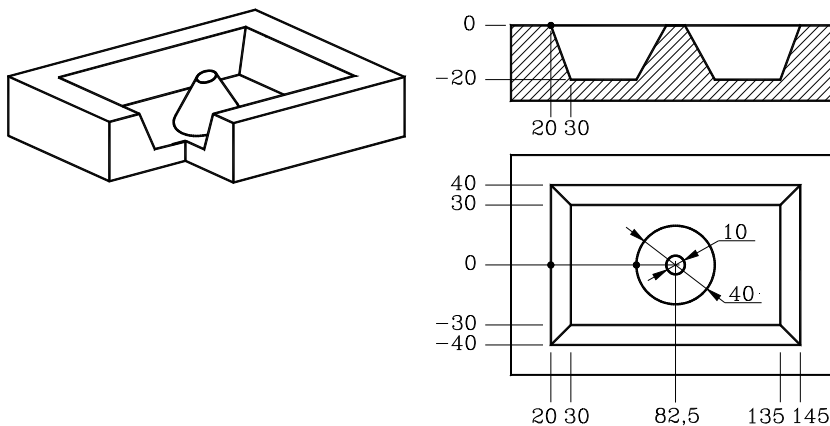

3D pocket = 2

Outside profile (P.XY).

P.XY= 4

[RECALL]

Configuration.

Abscissa axis: X

Ordinate axis: Y

Autozoom: Yes

Validate

Profile (pocket profile).

Initial point	X 20	Y 0	Validate
Straight line	X 20	Y -40	Validate
Straight line	X 145	Y -40	Validate
Straight line	X 145	Y 40	Validate
Straight line	X 20	Y 40	Validate
Straight line	X 20	Y 0	Validate

Profile (island profile).

Circle	X 62.5	Y 0	Xc 82.5	Yc 0	Validate
--------	--------	-----	---------	------	----------

End.

Save profile.

3.

WORKING WITH OPERATIONS OR CYCLES
Pocket cycle with a profile



FAGOR AUTOMATION

**CNC 8055
CNC 8055i**

·MC· OPTION
SOFT: V02.2X

Depth profile (P.Z1).

P.Z1= 2 [RECALL]

Configuration.

Abscissa axis: X Ordinate axis: Z

Autozoom: Yes Validate

Profile (pocket depth profile).

Initial point X 20 Z 0 Validate

Straight line X 30 Z -20 Validate

End.

Save profile.

Depth profile (P.Z2).

P.Z1= 3 [RECALL]

Configuration.

Abscissa axis: X Ordinate axis: Z

Autozoom: Yes Validate

Profile (island depth profile).

Initial point X 77.5 Z 0 Validate

Straight line X 62.5 Z -20 Validate

End.

Save profile.

3.

WORKING WITH OPERATIONS OR CYCLES
Pocket cycle with a profile



FAGOR AUTOMATION

CNC 8055
CNC 8055i

·MC· OPTION
SOFT: V02.2X

3.6 Rectangular and circular boss cycles



This key accesses the circular boss and rectangular boss operations.

Rectangular boss cycle.

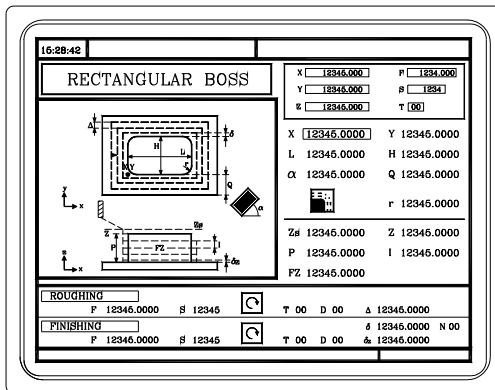

The following data must be defined:

- The starting point (X1, Y1), the dimensions of the boss (L, H), the inclination angle (α), the amount of stock to be removed (Q), the type of corner and the machining conditions in Z (Zs, Z, P, I, Fz).



- In the roughing area, define the milling pass (Δ) and the machining direction.
- In the finishing area, define the finishing stocks (δ and δz), the number of finishing passes and the machining direction.

Circular boss cycle.

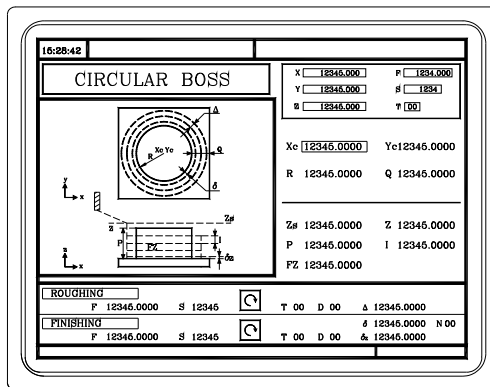

The following data must be defined:

- The center coordinates, (Xc, Yc), the radius of the boss (R), the amount of stock to be removed (Q) and the machining conditions in Z (Zs, Z, P, I, Fz).



- In the roughing area, define the milling pass (Δ) and the machining direction.
- In the finishing area, define the finishing stocks (δ and δz), the number of finishing passes and the machining direction.

3.
WORKING WITH OPERATIONS OR CYCLES
 Rectangular and circular boss cycles



CNC 8055
CNC 8055i

·MC· OPTION
SOFT: V02.2X

3.6.1 Definition of data

Rectangular boss. Position of the starting point.



The starting point of the boss may be located at a vertex or in the center. To select its position, place the cursor over this icon and press the two-color key.

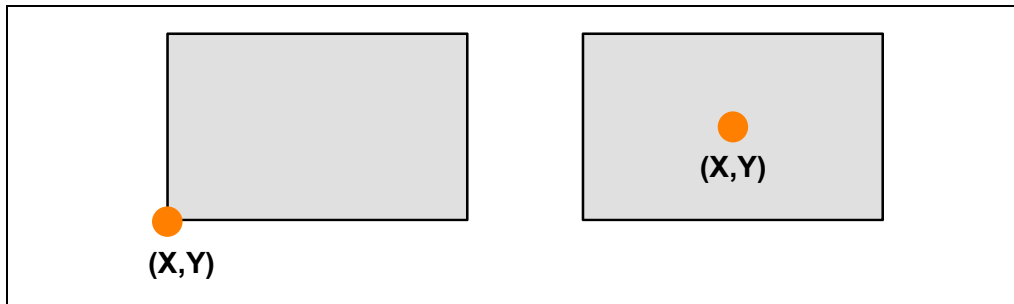

When associating multiple machining to a cycle, this point indicates the position where those machining operations are applied. See "3.13 Multiple positioning" on page 118.

Coordinates of the starting point.

The coordinates are defined one by one. After placing the cursor on the coordinates of the axes to be defined, the value is entered in one of the following ways.

- Entering the value manually. Key in the desired value and press [ENTER].
- Assign the current machine position.
Jog the axis with the handwheel or the JOG keys up to the desired point. Press [RECALL] so the selected data assumes the value shown in the top right window and press [ENTER].
The top right window shows the tool position at all times.

Rectangular boss: Dimensions, inclination angle and stock to be removed.

These data are defined one by one. Place the cursor in the corresponding window, key in the desired value and press [ENTER].

Type of corner.

Type of corner.

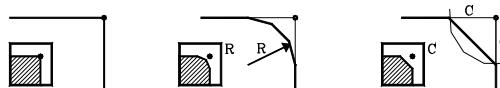

To select the type of corner, place the cursor over this icon and press the two-color key.

Circular boss: Center coordinates, radius and stock to be removed.

These data are defined one by one.

- The center coordinates (X_c , Y_c) are defined as the coordinates of the first and last points.
- To define the rest of the values (R , Q), go to the corresponding window, key in the desired value and press [ENTER].

Machining conditions in Z (Z_s , Z , P , I , F_z).

The machining conditions are defined one by one.

- The Z_s and Z values are defined as the coordinates of the first and last points.
- To define the rest of the values (P , I , F_z), go to the corresponding window, key in the desired value and press [ENTER].

If the penetration step is programmed with a positive sign ($I+$), the cycle recalculates the step so all the penetrations are identical, this being equal to or less than the one programmed. If programmed with a negative sign ($I-$), the cycle is machined with the given pass (step) except the last pass that machines the rest.

3.

WORKING WITH OPERATIONS OR CYCLES
Rectangular and circular boss cycles



FAGOR AUTOMATION

CNC 8055
CNC 8055i

·MC· OPTION
SOFT: V02.2X

Milling pass (Δ). Finishing stock on the side walls (δ) and at the bottom (δz). Number of finishing passes (N).

Place the cursor in the window for the finishing operation, key in the desired value and press [ENTER].

3.**WORKING WITH OPERATIONS OR CYCLES**

Rectangular and circular boss cycles



FAGOR AUTOMATION

**CNC 8055
CNC 8055i**·MC· OPTION
SOFT: V02.2X

3.7 Rectangular and circular pocket cycles



This key accesses the circular pocket and rectangular pocket operations.

Rectangular pocket cycle (level 1).

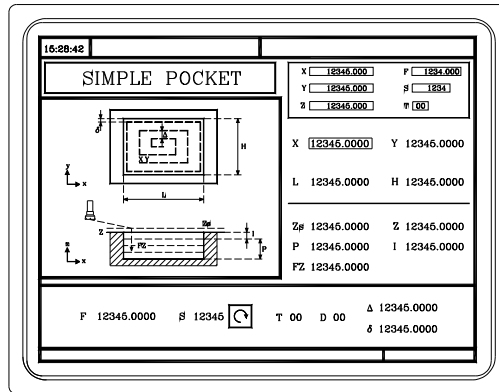

The following data must be defined:

- The starting point (X, Y), the pocket dimensions (L, H) and the machining conditions in Z (Zs, Z, P, I, Fz).



- Also, one must define the milling pass (Δ), the finishing stock (δ) and the machining direction.

Rectangular pocket cycle (level 2).

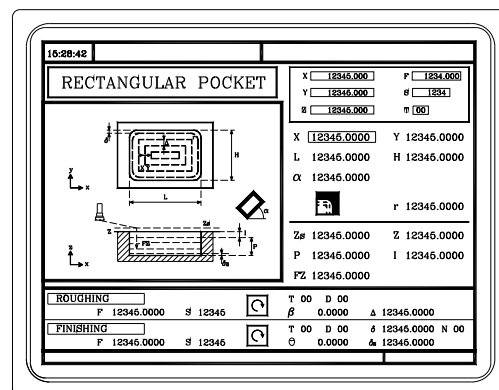

The following data must be defined:

- The starting point (X, Y), the pocket dimensions (L, H), the inclination angle (α), the type of corner and the machining conditions in Z (Zs, Z, P, I, Fz).



- In the roughing area, one must define the sideways penetration angle (β), the milling pass (Δ) and the machining direction.
- In the finishing area, one must define the sideways penetration angle (θ), the finishing stocks (δ and δ_z), the number of finishing passes (N) and the machining direction.

3.

WORKING WITH OPERATIONS OR CYCLES
Rectangular and circular pocket cycles



FAGOR AUTOMATION

CNC 8055
CNC 8055i

·MC· OPTION
SOFT: V02.2X

Circular pocket cycle (level 1).

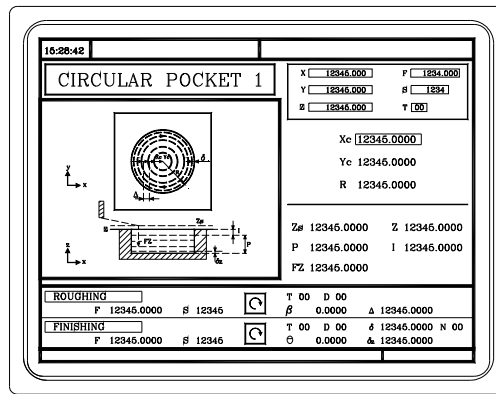

The following data must be defined:

- The center coordinates (Xc, Yc), the pocket radius (R) and the machining conditions in Z (Zs, Z, P, I, Fz).



- In the roughing area, one must define the sideways penetration angle (β), the milling pass (Δ) and the machining direction.
- In the finishing area, one must define the sideways penetration angle (θ), the finishing stocks (δ and δz), the number of finishing passes (N) and the machining direction.

Circular pocket cycle (level 2).

This level is the right one to machine pre-empted pockets or crowns.

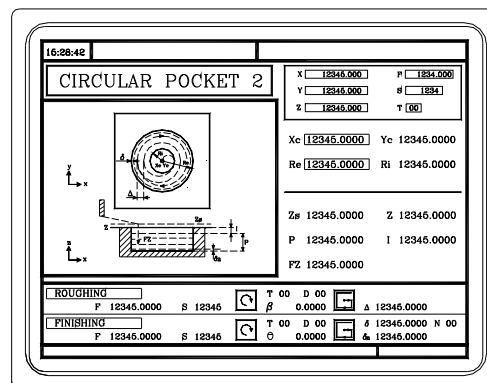

The following data must be defined:

- The center coordinates (Xc, Yc), the inside radius (Ri) and the outside radius (Re) of the pocket and the machining conditions in Z (Zs, Z, P, I, Fz).



- In the roughing area, one must define the sideways penetration angle (β), the milling pass (Δ) and the machining direction.
- In the finishing area, one must define the sideways penetration angle (θ), the finishing stocks (δ and δz), the number of finishing passes (N) and the machining direction.

3.
WORKING WITH OPERATIONS OR CYCLES
Rectangular and circular pocket cycles



FAGOR AUTOMATION

CNC 8055
CNC 8055i

·MC· OPTION
SOFT: V02.2X

3.7.1 Definition of data

Rectangular pocket. Position of the starting point.



The starting point of the pocket may be located at a vertex or in the center. To select its position, place the cursor over this icon and press the two-color key.

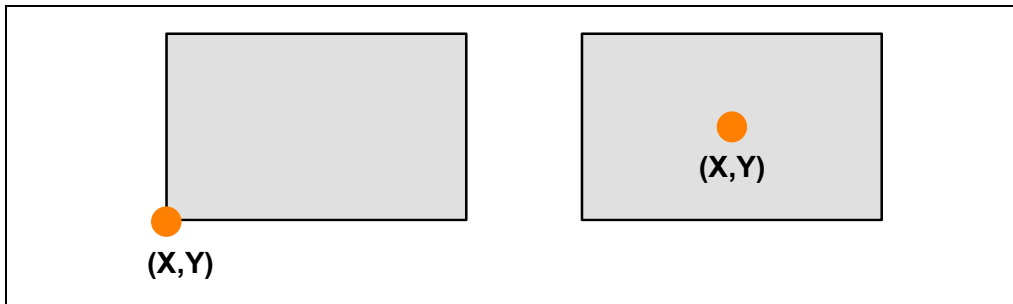

When associating multiple machining to a cycle, this point indicates the position where those machining operations are applied. See "3.13 Multiple positioning" on page 118.

Coordinates of the starting point.

The coordinates are defined one by one. After placing the cursor on the coordinates of the axes to be defined, the value is entered in one of the following ways.

- Entering the value manually. Key in the desired value and press [ENTER].
- Assign the current machine position.

Jog the axis with the handwheel or the JOG keys up to the desired point. Press [RECALL] so the selected data assumes the value shown in the top right window and press [ENTER].

The top right window shows the tool position at all times.

Rectangular pocket: Dimensions and inclination angle.

These data are defined one by one. Place the cursor in the corresponding window, key in the desired value and press [ENTER].

Type of corner.

Type of corner.

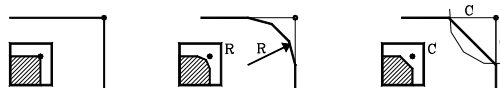

To select the type of corner, place the cursor over this icon and press the two-color key.

If the pocket dimensions do not allow the specified corner rounding or chamfer, the CNC will do the chamfer or the rounding with the maximum value possible.

Circular pocket: Center coordinate and radii.

These data are defined one by one.

- The center coordinates (X_c , Y_c) are defined as the coordinates of the first and last points.
- To define the radii (R , R_i , R_e), go to the corresponding window, key in the desired value and press [ENTER].

Machining conditions in Z (Z_s , Z , P , I , F_z).

The machining conditions are defined one by one.

- The Z_s and Z values are defined as the coordinates of the first and last points.
- To define the rest of the values (P , I , F_z), go to the corresponding window, key in the desired value and press [ENTER].

If the penetration step is programmed with a positive sign ($I+$), the cycle recalculates the step so all the penetrations are identical, this being equal to or less than the one programmed. If programmed with a negative sign ($I-$), the cycle is machined with the given pass (step) except the last pass that machines the rest.

3.

WORKING WITH OPERATIONS OR CYCLES
Rectangular and circular pocket cycles

FAGOR

FAGOR AUTOMATION

CNC 8055
CNC 8055i

-MC- OPTION
SOFT: V02.2X

Milling pass (Δ). Finishing stock on the side walls (δ) and at the bottom (δz). Number of finishing passes (N).

Place the cursor in the window for the finishing operation, key in the desired value and press [ENTER].

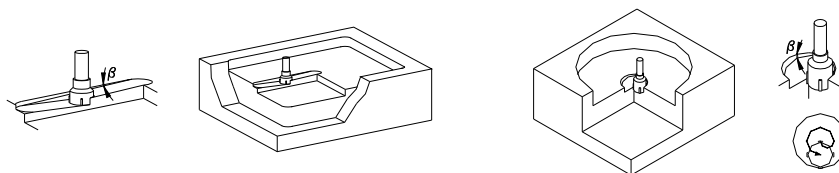
Sideways penetration angle (β , θ).

In the rectangular pocket, the penetration is carried out from the pocket center following the first machining path. The path is followed as many times as needed so it ends back in the center of the pocket.

In the circular pocket, the penetration is carried out from the pocket center following a helical path with a radius equal to that of the tool and keeping the machining direction. The penetration (in feed) always ends in the center of the pocket.

Place the cursor in the corresponding window, roughing or finishing operation, key in the desired value and press [ENTER].

3.

WORKING WITH OPERATIONS OR CYCLES
Rectangular and circular pocket cycles



FAGOR AUTOMATION

CNC 8055
CNC 8055i

·MC· OPTION
SOFT: V02.2X

3.8 Positioning (2 levels)



This key accesses the positioning operations.

Level 1.

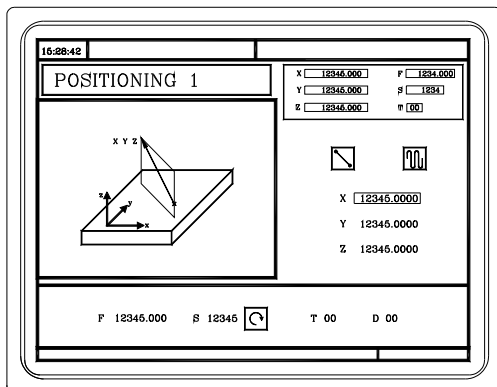

The following data must be defined:

- The target point ((X, Y, Z)), the axis moving order and the type of feedrate.

Level 2.

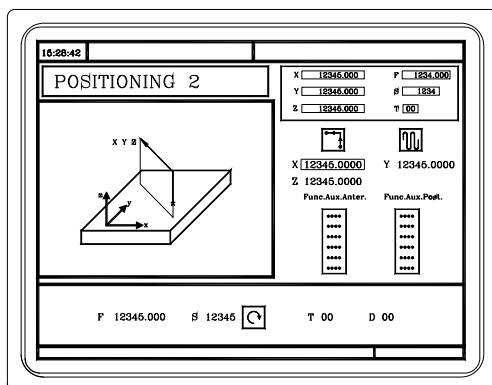

The following data must be defined:

- The target point (X, Y, Z), the axis moving order, the type of feedrate and the auxiliary "M" functions that will be executed before and after the movement.

3.

WORKING WITH OPERATIONS OR CYCLES
Positioning (2 levels)



FAGOR AUTOMATION

CNC 8055
CNC 8055i

-MC- OPTION
SOFT: V02.2X

3.8.1 Definition of data

Coordinates of the starting point.

The coordinates are defined one by one. After placing the cursor on the coordinates of the axes to be defined, the value is entered in one of the following ways.

- Entering the value manually. Key in the desired value and press [ENTER].
- Assign the current machine position.

Jog the axis with the handwheel or the JOG keys up to the desired point. Press [RECALL] so the selected data assumes the value shown in the top right window and press [ENTER].

The top right window shows the tool position at all times.

Order in which the axes move.



To select the moving order, place the cursor over this icon and press the two-color key.



All three axes at the same time.



First the Z axis and then the plane (X and Y axes at the same time).



First the plane (X and Y axes at the same time) and then the Z axis.

Type of feedrate.



To select the type of feedrate, place the cursor over this icon and press the two-color key.



Programmed feedrate.



Rapid feed.

Auxiliary "M" functions.

The functions will be executed in the same order as these are arranged on the list.

Select the corresponding window with the [←][→] keys Use the [↑][↓] keys to move around the window.

To delete a function, select it and press [CLEAR]

3.

WORKING WITH OPERATIONS OR CYCLES
Positioning (2 levels)



FAGOR AUTOMATION

CNC 8055
CNC 8055i

·MC· OPTION
SOFT: V02.2X

3.9 Boring operation



This key accesses the boring operations.

Boring operation (level 1).

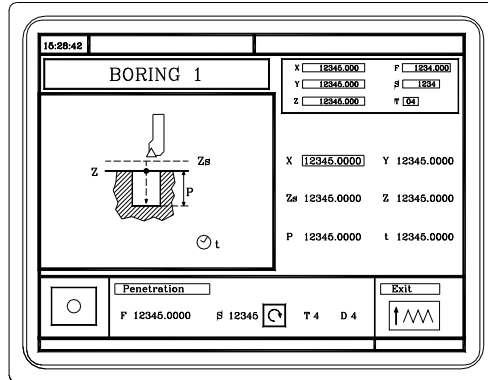

The following data must be defined:

- The machining point (X, Y), the coordinate of the safety plane (Zs), the coordinate of the part surface (Z), the total machining depth (P) and the dwell at the bottom (t).

Boring operation (level 2).

This level is only available when using spindle orientation. This level may be used, after the quail has penetrated, to orient the spindle, retract the quail before the exit movement, thus preventing the part from scratching.

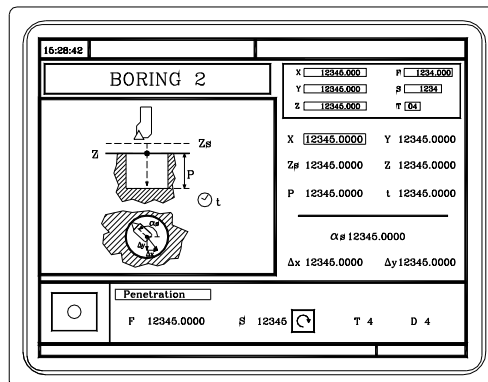

The following data must be defined:

- The machining point (X, Y), the coordinate of the safety plane (Zs), the coordinate of the part surface (Z), the total machining depth (P) and the dwell at the bottom (t) and the data for quail orientation and retraction (α s, Δ x, Δ y).

3.

WORKING WITH OPERATIONS OR CYCLES
Boring operation



FAGOR AUTOMATION

CNC 8055
CNC 8055i

-MC- OPTION
SOFT: V02.2X

3.9.1 Definition of data

Coordinates of the machining point.

The coordinates are defined one by one. After placing the cursor on the coordinates of the axes to be defined, the value is entered in one of the following ways.

- Entering the value manually. Key in the desired value and press [ENTER].
- Assign the current machine position.

Jog the axis with the handwheel or the JOG keys up to the desired point. Press [RECALL] so the selected data assumes the value shown in the top right window and press [ENTER].

The top right window shows the tool position at all times.

Machining conditions in Z (Z_s , Z , P , I , t).

The machining conditions are defined one by one.

- The Z_s and Z values are defined as the coordinates of the machining point.
- To define the rest of the values (P , t), go to the corresponding window, key in the desired value and press [ENTER].

Exit type at level 1.

The exit movement may be done in two ways:



To select the type of exit, place the cursor over this icon and press the two-color key.



At machining feedrate (G01) and with the spindle turning.



In rapid (G00) and with the spindle stopped.

Data for quail orientation and retraction (α_s , D_x , D_y).

These data are defined one by one. Place the cursor in the corresponding window, key in the desired value and press [ENTER].

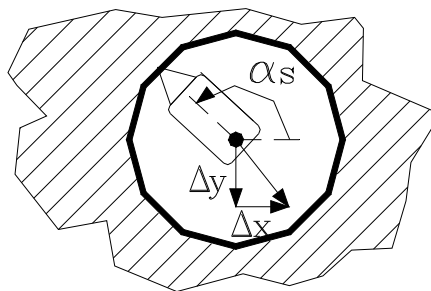

It first orients the quail, it then moves back in XY and finally goes up in rapid (G00) with the spindle stopped.

3.10 Reaming operation



This key accesses the reaming operation.

Reaming operation.

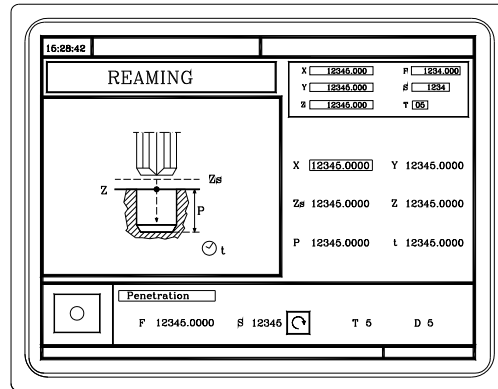

The following data must be defined:

- The machining point (X, Y), the coordinate of the safety plane (Zs), the coordinate of the part surface (Z), the total machining depth (P) and the dwell at the bottom (t).

3.

WORKING WITH OPERATIONS OR CYCLES
Reaming operation



FAGOR AUTOMATION

CNC 8055
CNC 8055i

-MC- OPTION
SOFT: V02.2X

3.10.1 Definition of data

Coordinates of the machining point.

The coordinates are defined one by one. After placing the cursor on the coordinates of the axes to be defined, the value is entered in one of the following ways.

- Entering the value manually. Key in the desired value and press [ENTER].
- Assign the current machine position.

Jog the axis with the handwheel or the JOG keys up to the desired point. Press [RECALL] so the selected data assumes the value shown in the top right window and press [ENTER].

The top right window shows the tool position at all times.

Machining conditions in Z (Zs, Z, P, I, t).

The machining conditions are defined one by one.

- The Zs and Z values are defined as the coordinates of the machining point.
- To define the rest of the values (P, t), go to the corresponding window, key in the desired value and press [ENTER].

3.

WORKING WITH OPERATIONS OR CYCLES
Remaining operation



FAGOR AUTOMATION

CNC 8055
CNC 8055i

·MC· OPTION
SOFT: V02.2X

3.11 Tapping operation



This key accesses the threading and thread milling operations.

Threading operation (level 1).

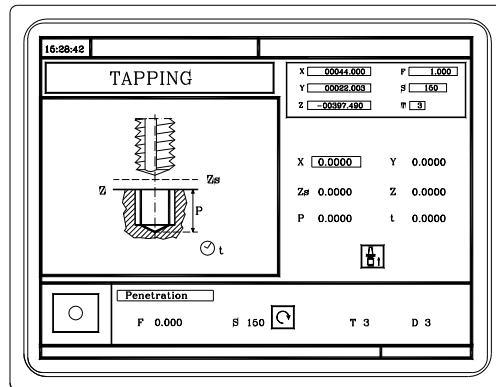

The following data must be defined:

- The machining point (X, Y), the coordinate of the safety plane (Zs), the coordinate of the part surface (Z), the total machining depth (P) and the dwell at the bottom (t) and the type of tapping.

Thread milling operation (level 2).

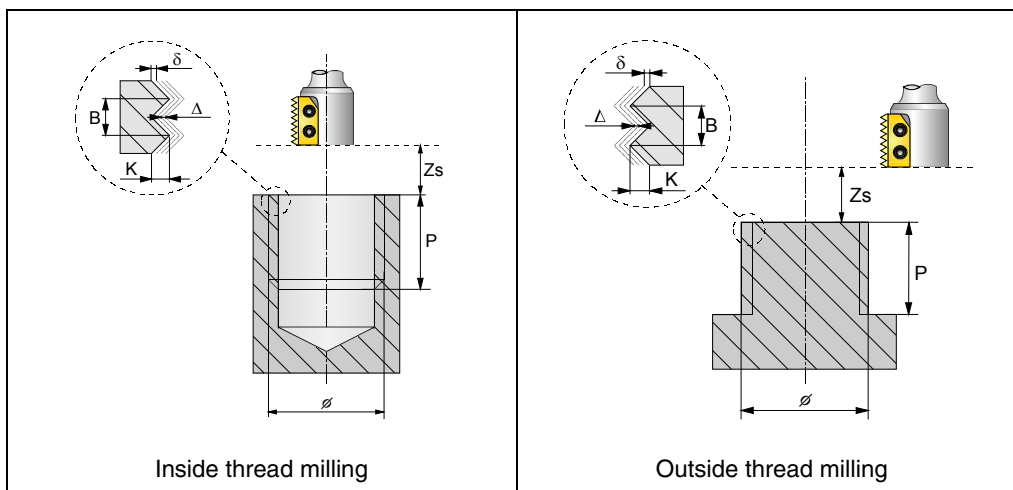

The following data must be defined:

- The type of threading (inside or outside), the machining point (X,Y), the coordinate of the safety plane (Zs), the part surface coordinate (Z), the total machining depth (P), the nominal diameter of the thread (ϕ), the depth of the thread (K), the thread pitch (B), the approach distance to the thread start point (Ds), the thread entry angle (α), the thread machining direction, the type of tool to use and the number of cutter edges (N).

3.

WORKING WITH OPERATIONS OR CYCLES
Tapping operation



FAGOR AUTOMATION

CNC 8055
CNC 8055i

.MC· OPTION
SOFT: V02.2X

3.11.1 Definition of data (threading)

Coordinates of the machining point.

The coordinates are defined one by one. After placing the cursor on the coordinates of the axes to be defined, the value is entered in one of the following ways.

- Entering the value manually. Key in the desired value and press [ENTER].
- Assign the current machine position.

Jog the axis with the handwheel or the JOG keys up to the desired point. Press [RECALL] so the selected data assumes the value shown in the top right window and press [ENTER].

The top right window shows the tool position at all times.

Machining conditions in Z (Zs, Z, P, I, t).

The machining conditions are defined one by one.

- The Zs and Z values are defined as the coordinates of the machining point.
- To define the rest of the values (P, t), go to the corresponding window, key in the desired value and press [ENTER].

Type of tapping.



Rigid tapping.

Without a clutch.



Rigid tapping with relief.



Non-rigid tapping.

With a clutch.

Selecting rigid tapping with relief displays two fields for defining the penetration step and the withdrawal distance.

- I Penetration step
- B Withdrawal distance

Thread definition.

The cycle offers two ways to define the thread:

- Defining the pitch (p) the spindle speed (S).
- Defining the feedrate (F) the spindle speed (S).

To select one of the ways, the "Penetration" area shows an icon with 2 states [p, S] and [F, S]. To select the desired one, select the icon and press the two-color key, the cycle will show the selected fields.

3.

WORKING WITH OPERATIONS OR CYCLES
Tapping operation



FAGOR AUTOMATION

CNC 8055
CNC 8055i

·MC· OPTION
SOFT: V02.2X

TOOL WITHDRAWAL

While machining, the CNC lets withdraw the tool to the starting plane stopping the spindle when the tool reaches the starting plane.

Activating PLC mark RETRACYC (M5065) stops the main axis and the spindle, the tool is withdrawn changing the direction of the axis and spindle while keeping the machining F and S values.

The stopping and starting sequence of the spindle and the axis when tapping keeps the same synchronism and dwells as during the execution of the canned cycle.

Options after tool withdrawal

Once the tool has been retracted, the user will have the following options:

- Finish the hole.
- Go to the next hole.
- Go into tool inspection.

After this, the CNC will display the following message:

"To end the cycle, press START to skip to the next SKIPCYCL".

Finish the hole:

To finish the hole, press the [START] key.

The hole is repeated from the starting plane under the same F and S conditions without stopping at the point where it stopped.

Go to the next hole:

To go to the next hole, activate the PLC mark SKIPCYCL.

The CNC will display the following message:

"Press [START] to continue".

Pressing the [START] key, the CNC considers the cycle to be finished and continues with the next block.

Go into tool inspection

If you don't wish to finish the hole nor go to the next hole, it is possible to go into a standard tool inspection.

In this case, a block must be selected and a standard repositioning must be done before resuming the execution of the program.

After inspecting the tool, once repositioning is done, the following choices will be offered:

- Resume the interrupted cycle.
- Skip the interrupted cycle and resume at the next block.

3.

WORKING WITH OPERATIONS OR CYCLES
Tapping operation

FAGOR 

FAGOR AUTOMATION

CNC 8055
CNC 8055i

·MC· OPTION
SOFT: V02.2X

3.11.2 Definition of data (thread milling)

Coordinates of the machining point.

The coordinates are defined one by one. After placing the cursor on the coordinates of the axes to be defined, the value is entered in one of the following ways.

- Entering the value manually. Key in the desired value and press [ENTER].
- Assign the current machine position.

Jog the axis with the handwheel or the JOG keys up to the desired point. Press [RECALL] so the selected data assumes the value shown in the top right window and press [ENTER].

The top right window shows the tool position at all times.

Type of threading



Defines the type of threading to be carried out (inside or outside).

[Zs] Safety coordinate

Defines the safety plane coordinate along the Z axis.

[Z] Part surface

Defines the Z coordinate of the part surface.

[P] Machining depth

Defines the total milling depth. If programmed with a 0 value, the CNC will display the corresponding error message.

[ϕ] Thread diameter

Defines the nominal diameter of the thread. If not programmed or programmed with a 0 value, the CNC will display the corresponding error message.

[K] Thread depth

It defines the distance between the crest and the root of the thread. If not programmed, the CNC issues the corresponding error.

[B] Thread pitch

Defines the thread pitch. If not programmed or programmed with a 0 value, the CNC will display the corresponding error message.

[Ds] Approach distance

Approach distance to the thread entry. If not programmed or programmed with a 0 value, it will enter the thread from the center of the hole.

[α] Thread entry (start) angle

Angle (in degrees) of the segment formed by the center of the hole and the thread entry point with respect to the abscissa axis. If not programmed, a value of 0 is assumed.

3.

WORKING WITH OPERATIONS OR CYCLES
Tapping operation



FAGOR AUTOMATION

CNC 8055
CNC 8055i

·MC· OPTION
SOFT: V02.2X

Thread cutting direction

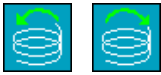

It defines the thread cutting direction.

Thread cutting direction



It defines the thread cutting direction (from the part surface down to the bottom of the thread or from the bottom up to the part surface).

Tool type

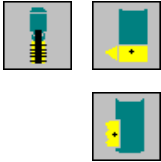

It defines the type of tool used for machining.

- Single-pitch thread.
- Thread cutting one thread per each pass (Single-edge cutter).
- Thread cutting n threads per each pass (n-edge cutter).

[N] Number of cutting edges of the cutter.

It defines the number of cutting edges of the cutter (only when machining with a cutter of n edges). If not programmed or programmed with a 0 value, the CNC will display the corresponding error message.

3.

WORKING WITH OPERATIONS OR CYCLES
Tapping operation

3.12 Drilling and center punching operations



This key accesses the drilling, center punching and bore milling operations.

Center punching operation.

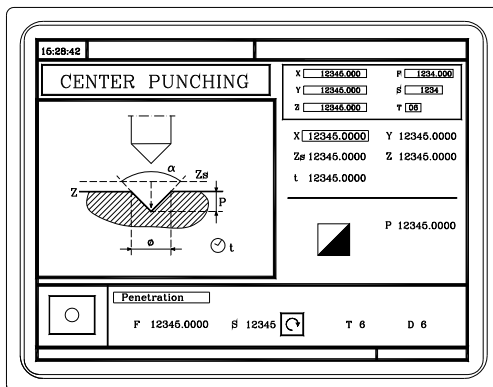

The following data must be defined:

- The machining point (X, Y), the coordinate of the safety plane (Zs), the coordinate of the part surface (Z), the dwell at the bottom (t) and the type of center punching.

Drilling operation (level 1).

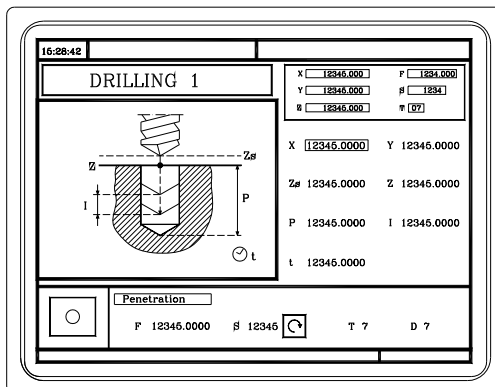

The following data must be defined:

- The machining point (X, Y), the coordinate of the safety plane (Zs), the coordinate of the part surface (Z), the total machining depth (P), the drilling peck (I) and the dwell at the bottom (t).

Drilling operation (level 2).

It may be used to set the withdrawal distance (B) after each penetration.

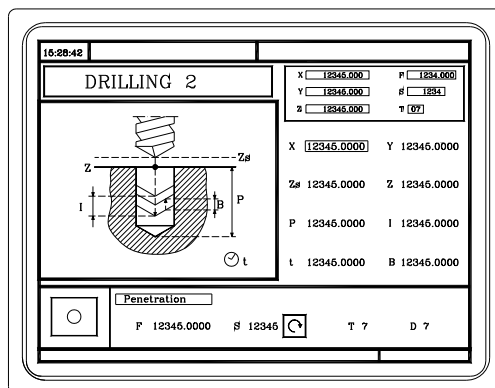

3.
WORKING WITH OPERATIONS OR CYCLES
Drilling and center punching operations



FAGOR AUTOMATION

CNC 8055
CNC 8055i

·MC· OPTION
SOFT: V02.2X

The following data must be defined:

- The machining point (X, Y), the coordinate of the safety plane (Zs), the coordinate of the part surface (Z), the total machining depth (P), the drilling peck (I) and the dwell at the bottom (t) and the withdrawal distance after each penetration (B).

Drilling operation (level 3).

It may be used to set the withdrawal coordinate (Zr) after each penetration.

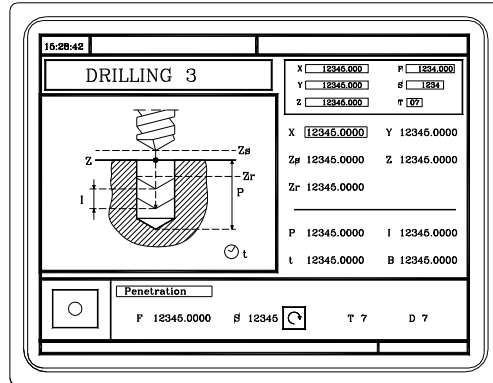

The following data must be defined:

- The machining point (X, Y), the coordinate of the safety plane (Zs), the coordinate of the part surface (Z), the withdrawal coordinate (Zr), the total machining depth (P), the drilling peck (I) and the dwell at the bottom (t).

Bore milling operation (level 5).

This cycle may be used to increase the diameter of a hole through a helical movement of the tool. Besides this, if the tool allows it, it is also possible to mill a hole without having to drill it first.

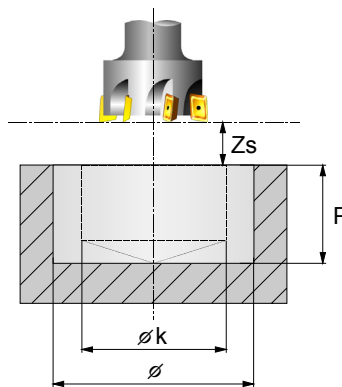

The following data must be defined:

- The machining point (X, Y), the coordinate of the safety plane (Zs), the coordinate of the part surface (Z), the hole diameter (ϕ), the diameter of the pre-drilled hole (ϕK), the total machining depth (P), the helical penetration pitch (B), the direction of the helical drilling path and the milling at the bottom.

3.

WORKING WITH OPERATIONS OR CYCLES
Drilling and center punching operations



FAGOR AUTOMATION

CNC 8055
CNC 8055i

-MC- OPTION
SOFT: V02.2X

3.12.1 Definition of data

Coordinates of the machining point.

The coordinates are defined one by one. After placing the cursor on the coordinates of the axes to be defined, the value is entered in one of the following ways.

- Entering the value manually. Key in the desired value and press [ENTER].
- Assign the current machine position.

Jog the axis with the handwheel or the JOG keys up to the desired point. Press [RECALL] so the selected data assumes the value shown in the top right window and press [ENTER].

The top right window shows the tool position at all times.

Machining conditions in Z (Zs, Z, Zr, P, I, t, B).

The machining conditions are defined one by one.

- The Zs and Z values are defined as the coordinates of the machining point.
- To define the rest of the values (Zr, P, I, t, B), go to the corresponding window, key in the desired value and press [ENTER].

Type of center punching.



To select the type of tapping, place the cursor over this icon and press the two-color key. The type of center punching may be defined in two ways.

- Defining the total machining depth (P).
- Defining the angle of the punch (α) and the diameter of the point (Φ).

To define the values (P, α , Φ), go to the corresponding window, key in the desired value and press [ENTER].

Hole diameter (ϕ).

Defines the diameter of the hole. To set this value, place the cursor in the corresponding window, key in the desired value and press [ENTER].

If not programmed or programmed with a 0 value, the CNC will display the corresponding error message.

Diameter of the pre-drilled hole (ϕK).

Starting with a hole previously drilled, this parameter defines the diameter of that hole. If not programmed or programmed with a 0 value, it means that no hole has been previously drilled.

The tool must meet the following conditions:

- The tool radius must be smaller than J/2.
- The tool radius must be equal to or larger than (J-K)/4.

If these two conditions are not met, the CNC issues the corresponding error.

Helical penetration step (B).

It defines the helical penetration step (only for bore milling). To set this value, place the cursor in the corresponding window, key in the desired value and press [ENTER].

If not programmed or programmed with a 0 value, the CNC will display the corresponding error message.

Drilling direction.



Defines the direction of the helical drilling path.

Bottom milling.



It defines whether the bottom of the hole (blind hole) is milled or not (through hole).

3.

WORKING WITH OPERATIONS OR CYCLES
Drilling and center punching operations



FAGOR AUTOMATION

CNC 8055
CNC 8055i

-MC- OPTION
SOFT: V02.2X

3.12.2 Tool withdrawal

While drilling a hole, the CNC lets withdraw the tool to the starting plane stopping the spindle when the tool reaches the starting plane.

Activating PLC mark RETRACYC (M5065) stops the main axis and the tool is withdrawn without stopping the spindle. The spindle stops when the tool is retracted, once it reaches the starting plane.

Options after tool withdrawal

Once the tool has been retracted, the user will have the following options:

- Finish the hole.
- Go to the next hole.
- Go into tool inspection.

After this, the CNC will display the following message:

"To end the cycle, press START to skip to the next SKIPCYCL".

Finish the hole:

To finish the hole, press the [START] key.

It goes down in G0 with spindle running to 1 mm before the coordinate where the hole stopped. From then on, it continues at the F and S programmed in the cycle.

Go to the next hole:

To go to the next hole, activate the PLC mark SKIPCYCL.

The CNC will display the following message:

"Press [START] to continue".

Pressing the [START] key, the CNC considers the cycle to be finished and continues with the next block.

Go into tool inspection

If you don't wish to finish the hole nor go to the next hole, it is possible to go into a standard tool inspection.

In this case, a block must be selected and a standard repositioning must be done before resuming the execution of the program.

After inspecting the tool, once repositioning is done, the following choices will be offered:

- Resume the interrupted cycle.
- Skip the interrupted cycle and resume at the next block.

3.

WORKING WITH OPERATIONS OR CYCLES
Drilling and center punching operations

FAGOR 

FAGOR AUTOMATION

CNC 8055
CNC 8055i

·MC· OPTION
SOFT: V02.2X

3.13 Multiple positioning

Some cycles may be carried out in the tool position or may be associated a multiple positioning so the cycle may be repeated in several locations. Multiple positioning may be associated with the following cycles.

- Boring, reaming, tapping, drilling and center punching operations.
- 2D and 3D pockets.
- Bosses.

Use the following keys to select multiple positioning. The positioning moves may be selected with each one of the following keys:



Multiple positioning in several locations.



Multiple positioning in a straight line.



Multiple positioning in an arc.



Multiple positioning in a rectangular pattern.



Multiple positioning in a grid pattern.

When using one of these keys, the CNC selects the corresponding positioning and changes the display on the screen. The CNC keeps the lamp for the selected operation (pocket, boss, boring, reaming, etc.) on and the bottom of the screen shows the data for that operation.

Associating a multiple positioning with a cycle

A multiple positioning may be associated with a cycle as follows:

1. Definition of the machining cycle, including the position of the starting point.
2. Selection of the type of positioning to be associated with.
3. Programming of the different points of the positioning.

The cycle assumes as first positioning point the starting point of the machining operation. This point may be modified when defining the positioning.

In 2D and 3D pockets, the reference points for the positioning must be the starting point of the outside profile.

To de-select a cycle and return to the standard screen, press the key for the selected cycle (the one with the lamp on) or the [ESC] key.

Multiple positioning in pockets and bosses

The screens of the pockets and bosses will indicate with icons which positioning they have associated or whether they are alone.

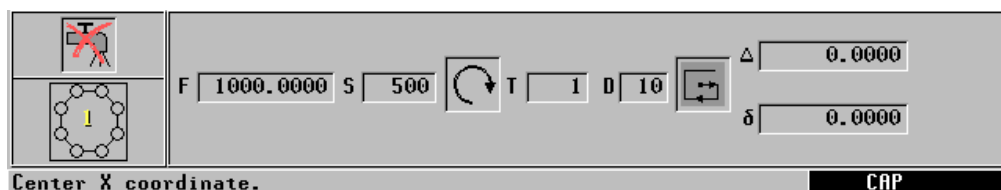

In the positioning, an icon will show the pocket or boss to be repeated and the bottom screen will give information on its geometry (except in profile pockets). The starting position of rectangular pockets and bosses may be changed; the positioning movements will be different depending on whether the starting point is at the vertex or in the center.

3.

WORKING WITH OPERATIONS OR CYCLES
Multiple positioning



FAGOR AUTOMATION

CNC 8055
CNC 8055i

·MC· OPTION
SOFT: V02.2X

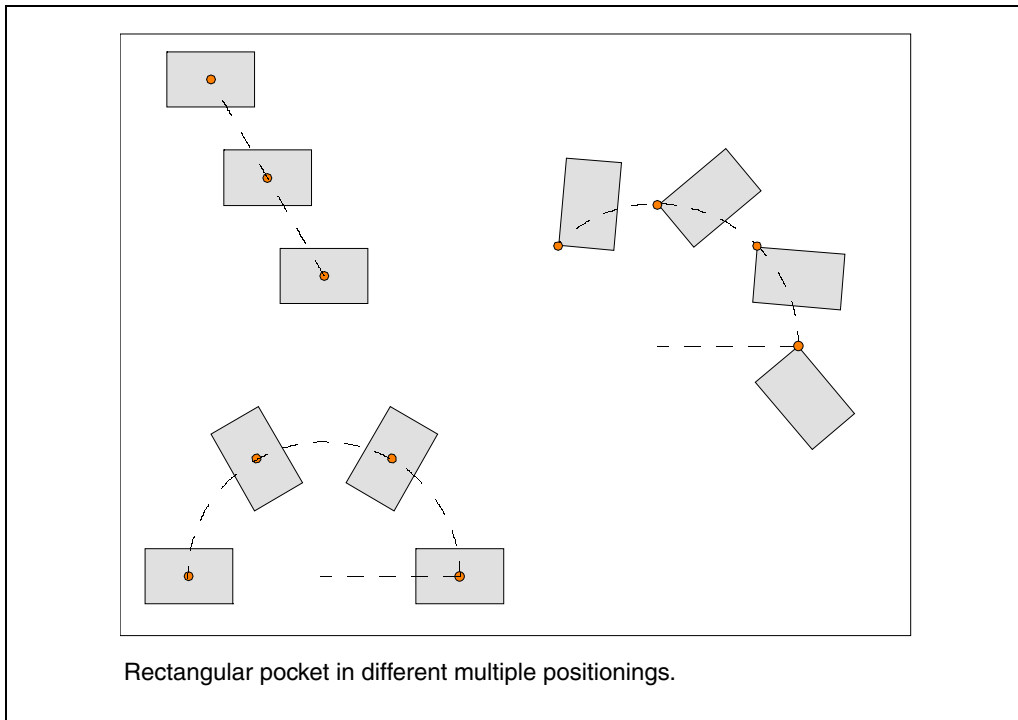
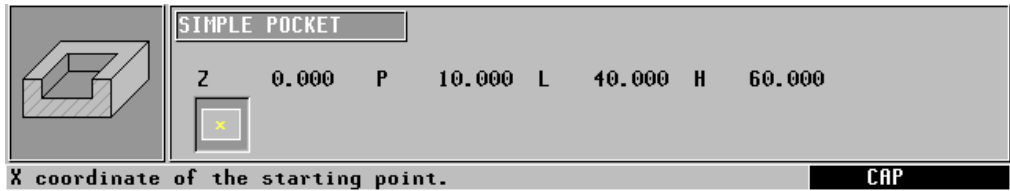

When machining pockets and bosses at the different positions, proceed as follows:

- There is neither roughing or finishing operation.
The machining takes place point to point; the whole cycle is executed at each point (there is no tool change).
- There is a roughing and finishing operation with the same tool and it is not possible to program "M" functions between them.
The machining takes place point to point; the whole cycle is executed at each point (there is no tool change).
- There is a roughing and finishing operation with a different tool or it is possible to program "M" functions between them.
It first does the roughing and then all the finishing operations (only one tool change).



The availability of "M" functions in the cycles is determined with g.m.p. "CODISET (P147)".

3.

WORKING WITH OPERATIONS OR CYCLES
Multiple positioning



FAGOR AUTOMATION

CNC 8055
CNC 8055i

-MC- OPTION
SOFT: V02.2X

3.13.1 Multiple positioning in several locations



This key associates this positioning with the active operation.

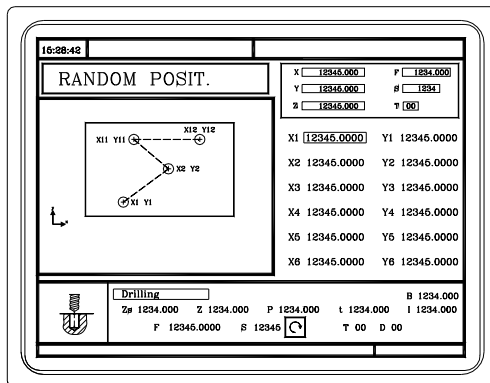

Up to 12 points (X1, Y1) ... (X12, Y12) may be defined. When not using the 12 definition points, the first unused point must be defined with the same coordinates as the last point.

Data definition.

The coordinates are defined one by one. After placing the cursor on the coordinates of the axes to be defined, the value is entered in one of the following ways.

- Entering the value manually. Key in the desired value and press [ENTER].
- Assign the current machine position.

Jog the axis with the handwheel or the JOG keys up to the desired point. Press [RECALL] so the selected data assumes the value shown in the top right window and press [ENTER].

The top right window shows the tool position at all times.

If a coordinate is left blank, the cycle will assume that it is the same as that of the previous one.

If defined...		The CNC assumes...
X1 25.323	Y1 26.557	Point: X1 25.323 Y1 26.557
X2	Y2 78.998	Point: X2 25.323 Y2 78.998
X3 67.441	Y3 83.231	Point: X3 67.441 Y3 83.231
X4	Y4	Point: X4 67.441 Y4 83.231
X5	Y5	There are no more points, it is a repetition of the previous point.

The coordinates of each point may also be defined incrementally. To do that, select the desired coordinate with the cursor and press the two-color key. Both coordinates of the selected point will be shown preceded by the "Δ" icon that indicates the incremental value with respect to the previous point.

3.
 WORKING WITH OPERATIONS OR CYCLES
 Multiple positioning



CNC 8055
CNC 8055i

·MC· OPTION
SOFT: V02.2X

3.13.2 Multiple positioning in a straight line



This key associates this positioning with the active operation.

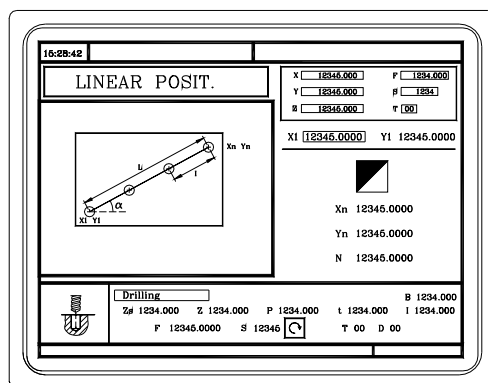

The positioning may be defined in 5 ways. To select the desired type, place the cursor over the icon and press the two-color key. The icon shows the selected option and the total number of options available.

- | | | |
|----|--|--------------|
| 1) | Coordinates of the starting point. | (X1, Y1) |
| | Coordinates of the last point. | (Xn, Yn) |
| | Distance between machining operations. | (I) |
| 2) | Coordinates of the starting point. | (X1, Y1) |
| | Coordinates of the last point. | (Xn, Yn) |
| | Number of points to machine. | (N) |
| 3) | Coordinates of the starting point. | (X1, Y1) |
| | Inclination angle. | (α) |
| | Distance to travel. | (L) |
| | Distance between machining operations. | (I) |
| 4) | Coordinates of the starting point. | (X1, Y1) |
| | Inclination angle. | (α) |
| | Distance to travel. | (L) |
| | Number of points to machine. | (N) |
| 5) | Coordinates of the starting point. | (X1, Y1) |
| | Inclination angle. | (α) |
| | Number of points to machine. | (N) |
| | Distance between machining operations. | (I) |

Data definition.

The coordinates are defined one by one. After placing the cursor on the coordinates of the axes to be defined, the value is entered in one of the following ways.

- Entering the value manually. Key in the desired value and press [ENTER].
- Assign the current machine position.

Jog the axis with the handwheel or the JOG keys up to the desired point. Press [RECALL] so the selected data assumes the value shown in the top right window and press [ENTER].

The top right window shows the tool position at all times.

To define the rest of the values (I, N, α , L), go to the corresponding window, key in the desired value and press [ENTER].

3.

WORKING WITH OPERATIONS OR CYCLES
Multiple positioning

FAGOR 

FAGOR AUTOMATION

CNC 8055
CNC 8055i

-MC- OPTION
SOFT: V02.2X

3.13.3 Multiple positioning in an arc



This key associates this positioning with the active operation.

Multiple positioning in an arc (level 1).

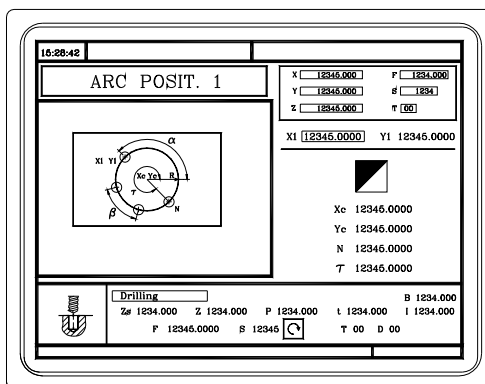

The positioning may be defined in 6 ways. To select the desired type, place the cursor over the icon and press the two-color key. The icon shows the selected option and the total number of options available.

- | | | |
|----|---|--------------|
| 1) | Coordinates of the starting point | (X1, Y1) |
| | Center coordinates | (Xc, Yc) |
| | Angle of the last point | (τ) |
| | Angular distance between machining operations | (β) |
| 2) | Coordinates of the starting point | (X1, Y1) |
| | Radius | (R) |
| | Angle of the starting point | (α) |
| | Angle of the last point | (τ) |
| | Angular distance between machining operations | (β) |
| 3) | Coordinates of the starting point | (X1, Y1) |
| | Center coordinates | (Xc, Yc) |
| | Number of points to machine | (N) |
| | Angle of the last point | (τ) |
| 4) | Coordinates of the starting point | (X1, Y1) |
| | Center coordinates | (Xc, Yc) |
| | Number of points to machine | (N) |
| | Angular distance between machining operations | (β) |
| 5) | Coordinates of the starting point | (X1, Y1) |
| | Radius | (R) |
| | Angle of the starting point | (α) |
| | Number of points to machine | (N) |
| | Angle of the last point | (τ) |
| 6) | Coordinates of the starting point | (X1, Y1) |
| | Radius | (R) |
| | Angle of the starting point | (α) |
| | Number of points to machine | (N) |
| | Angular distance between machining operations | (β) |

3.
 WORKING WITH OPERATIONS OR CYCLES
 Multiple positioning



CNC 8055
CNC 8055i

.MC· OPTION
SOFT: V02.2X

Multiple positioning in an arc (level 2).

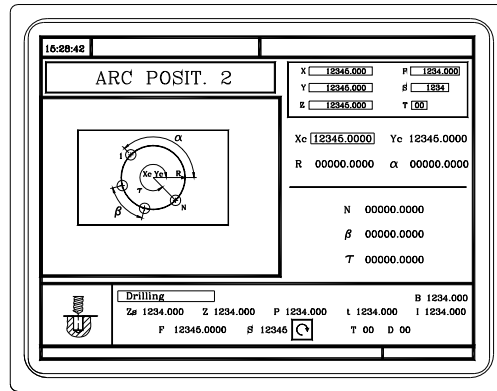

The following data must be defined:

- Center coordinates (Xc, Yc).
- The starting point in Polar coordinates; Radius (R) and angle (α).

2 of the following data must be defined. When defining all 3 of them (if they are other than 0), the cycle assumes the (N) and (β) values.

- (N) Number of points to machine.
- (β) Angular distance between machining operations.
- (τ) Angle of the last point.

Data definition.

The coordinates are defined one by one. After placing the cursor on the coordinates of the axes to be defined, the value is entered in one of the following ways.

- Entering the value manually. Key in the desired value and press [ENTER].
- Assign the current machine position.

Jog the axis with the handwheel or the JOG keys up to the desired point. Press [RECALL] so the selected data assumes the value shown in the top right window and press [ENTER].

The top right window shows the tool position at all times.

To define the rest of the values (R, N, α , β , τ), go to the corresponding window, key in the desired value and press [ENTER].

3.

WORKING WITH OPERATIONS OR CYCLES
Multiple positioning



FAGOR AUTOMATION

CNC 8055
CNC 8055i

-MC- OPTION
SOFT: V02.2X

3.13.4 Multiple positioning in a rectangular pattern



This key associates this positioning with the active operation.

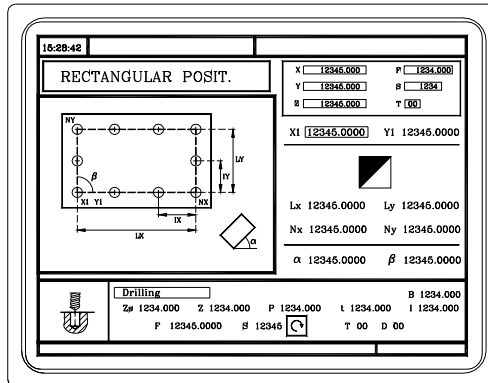

The positioning may be defined in 3 ways. To select the desired type, place the cursor over the icon and press the two-color key. The icon shows the selected option and the total number of options available.

- | | | |
|----|---|--------------|
| 1) | Coordinates of the starting point | (X1, Y1) |
| | X and Y lengths | (Lx, Ly) |
| | X and Y distances between machining operations. | (Ix, Iy) |
| | Rotation angle | (α) |
| | Angle between paths | (β) |
| 2) | Coordinates of the starting point | (X1, Y1) |
| | X and Y lengths | (Lx, Ly) |
| | Number of machining operations on X and Y | (Nx, Ny) |
| | Rotation angle | (α) |
| | Angle between paths | (β) |
| 3) | Coordinates of the starting point | (X1, Y1) |
| | X and Y distances between machining operations. | (Ix, Iy) |
| | Number of machining operations on X and Y | (Nx, Ny) |
| | Rotation angle | (α) |
| | Angle between paths | (β) |

Data definition.

The coordinates are defined one by one. After placing the cursor on the coordinates of the axes to be defined, the value is entered in one of the following ways.

- Entering the value manually. Key in the desired value and press [ENTER].
- Assign the current machine position.

Jog the axis with the handwheel or the JOG keys up to the desired point. Press [RECALL] so the selected data assumes the value shown in the top right window and press [ENTER].

The top right window shows the tool position at all times.

To define the rest of the values (Lx, Ly, Ix, Iy, α , β , Nx, Ny), go to the corresponding window, key in the desired value and press [ENTER].

3.

WORKING WITH OPERATIONS OR CYCLES
Multiple positioning



FAGOR AUTOMATION

CNC 8055
CNC 8055i

·MC· OPTION
SOFT: V02.2X

3.13.5 Multiple positioning in a grid pattern



This key associates this positioning with the active operation.

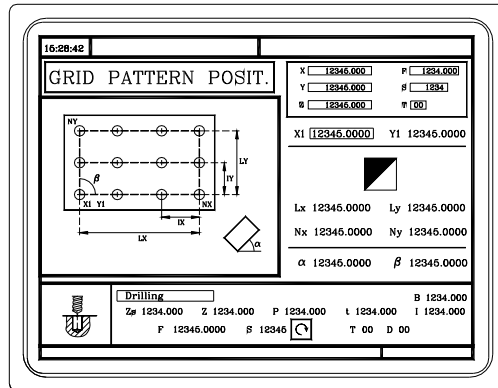

The positioning may be defined in 3 ways. To select the desired type, place the cursor over the icon and press the two-color key. The icon shows the selected option and the total number of options available.

- | | | |
|----|---|--------------|
| 1) | Coordinates of the starting point | (X1, Y1) |
| | X and Y lengths | (Lx, Ly) |
| | X and Y distances between machining operations. | (lx, ly) |
| | Rotation angle | (α) |
| | Angle between paths | (β) |
| 2) | Coordinates of the starting point | (X1, Y1) |
| | X and Y lengths | (Lx, Ly) |
| | Number of machining operations on X and Y | (Nx, Ny) |
| | Rotation angle | (α) |
| | Angle between paths | (β) |
| 3) | Coordinates of the starting point | (X1, Y1) |
| | X and Y distances between machining operations. | (lx, ly) |
| | Number of machining operations on X and Y | (Nx, Ny) |
| | Rotation angle | (α) |
| | Angle between paths | (β) |

Data definition.

The coordinates are defined one by one. After placing the cursor on the coordinates of the axes to be defined, the value is entered in one of the following ways.

- Entering the value manually. Key in the desired value and press [ENTER].
- Assign the current machine position.

Jog the axis with the handwheel or the JOG keys up to the desired point. Press [RECALL] so the selected data assumes the value shown in the top right window and press [ENTER].

The top right window shows the tool position at all times.

To define the rest of the values (Lx, Ly, lx, ly, α , β , Nx, Ny), go to the corresponding window, key in the desired value and press [ENTER].

3.

WORKING WITH OPERATIONS OR CYCLES
Multiple positioning

FAGOR 

FAGOR AUTOMATION

CNC 8055
CNC 8055i

·MC· OPTION
SOFT: V02.2X

3.

WORKING WITH OPERATIONS OR CYCLES

Multiple positioning



FAGOR AUTOMATION

CNC 8055
CNC 8055i

·MC· OPTION
SOFT: V02.2X

The ISO mode is accessed with the [ISO] key.

- When operating with operations or cycles, press the [ISO] key once.
- When operating in jog mode, press the [ISO] key twice; the first time to access the MDI mode and the second time to access the ISO mode. See *"2.10 ISO management"* on page 69.

Cycle levels

The ISO mode offers several editing levels. Each level has its own screen and the main window of the cycle indicates, with tabs, the available levels and which one is selected.



To change levels, use the [LEVEL CYCLE] key or the [page up] and [page down] keys to scroll up and down through the various levels.



Block editing

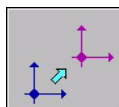

Zero offsets and presets

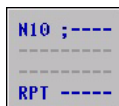

Insert labels and repetitions from label to label

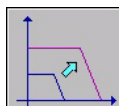

Scaling factor

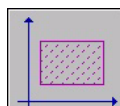

Work zones

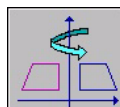

Mirror image

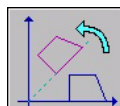

Coordinate rotation



Plane change

Simulating, executing or saving ISO cycles

Once the cycle data or the blocks have been edited, press [ESC]. The upper right side of the screen will show the "start" symbol. From this moment on, the edited blocks may be simulated, executed or saved like any operation or cycle.

- To simulate the blocks, press the [GRAPHICS] key.
- To execute the blocks, press the [START] key.
- To save the edited blocks, press the [P.PROG] key.

It is possible to combine ISO-coded blocks with standard and/or user machining cycles to create part-programs. See chapter *"5 Saving programs"*.



FAGOR AUTOMATION

CNC 8055
CNC 8055i

.MC- OPTION
SOFT: V02.2X

4.1 Editing blocks in ISO mode

When accessing the ISO mode, the CNC displays a special screen for editing up to 6 program blocks either in ISO code or in high level language. After editing a block, press [ENTER] to validate it.

Example:

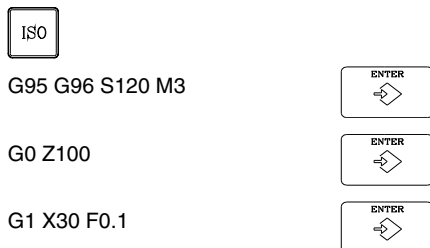

Once the block or blocks have been edited, press [ESC]. The upper right side of the screen will show the "start" symbol. From this moment on, the edited blocks may be simulated, executed or saved like any operation or cycle.

4.

OPERATING IN ISO MODE
Editing blocks in ISO mode



FAGOR AUTOMATION

CNC 8055
CNC 8055i

·MC· OPTION
SOFT: V02.2X

4.2 Programming assistance

4.2.1 Zero offsets and presets

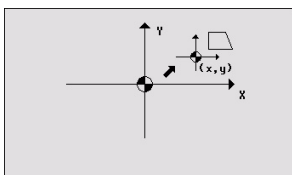

The icon may be used to select the following options:

- Machine zero. It cancels any zero offset and assumes the machine zero (home) as reference.
- Absolute zero offset. It permits defining, enabling or defining + enabling the absolute zero offsets (G54 ... G57, G159N7 ... G159N20).
- The zero offset is selected with an icon.
- Incremental offset: It permits defining, enabling or defining + enabling the incremental zero offsets (G58 or G59). The zero offset to be activated is selected with an icon.
- Preset: The preset value for the active axes may be edited on the screen. If you do not wish to preset any of them, leave its field empty (blank).

The cycle internally generates a block with function G53, G54...G59, G159N7...G159N20 or G92.

Pressing the [ZERO] key accesses the zero offset table.

4.2.2 Work zones

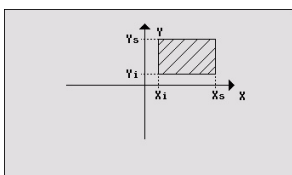

The icons may be used to defined the following options:

- Select the work zone to act upon. Up to five different zones may be defined.
- Type of action to carry out with the zone. A zone may be defined, enabled, defined+enabled or disabled.
- Define the type of zone. Each one of them may be defined either as a no-entry or no-exit zone.

The numeric fields permit editing the lower and upper limits of the zone. The limits are defined on the X, Y and Z axes. To only define either the upper or the lower limit, leave the values of the other limit blank.

The cycle internally generates up to three blocks with functions G20, G21 and G22.

4.2.3 Insert labels and repetitions from label to label

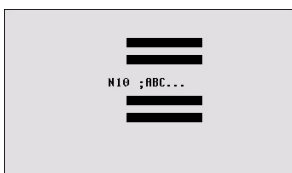

This cycle permits editing labels and repetition blocks between two labels. It is selected with an icon.

- Edit labels. There is a field to enter the block number an another one to add a comment.
The cycle generates this type of a block: N10; -> Comment.
- Block repetition. The repetition takes place between the first and final labels programmed, the number of times that is indicated.

The cycle internally generates an RPT block.

4.

OPERATING IN ISO MODE
Programming assistance

FAGOR 

FAGOR AUTOMATION

CNC 8055
CNC 8055i

-MC- OPTION
SOFT: V02.2X

4.2.4 Mirror image

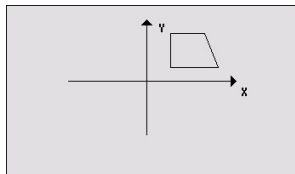

The icons may be used to select the following options:

- Select the action to be carried out. It is possible to cancel the active mirror image, define a new one canceling the previous ones or define a new one and add it to the one that is currently active.
- Select the axes on which mirror image is applied. For a new mirror image, you may select between the X, Y or X-Y axes. For an additive mirror image, you may select between the X and Y axes. This icon is not shown when selecting mirror image cancellation.

The cycle internally generates an ISO block that contains a combination of functions G10, G11 and G12.

4.2.5 Scaling factor

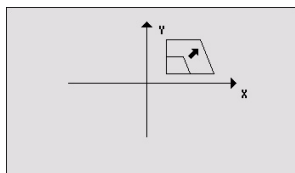

An icon is used to indicate whether to cancel the existing scaling factor or activate a new one. In the latter case, a numeric field is displayed to define the value of the scaling factor.

The cycle internally generates a block with function G72.

4.2.6 Coordinate rotation

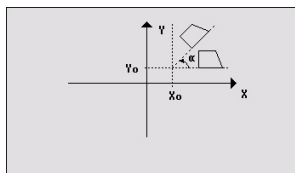

An icon is used to select the action to be carried out. It is possible to cancel the active coordinate rotation, define a new one canceling the previous one or define a new one adding it to the one currently active.

To define or activate a coordinate rotation, it shows three numeric fields to edit the angle and the center of rotation.

The cycle internally generates two blocks with function G73.

4.

OPERATING IN ISO MODE
Programming assistance



FAGOR AUTOMATION

CNC 8055
CNC 8055i

·MC· OPTION
SOFT: V02.2X

4.2.7 Plane change

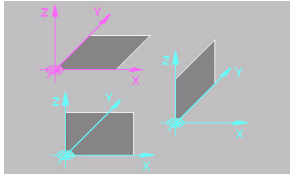

An icon may be used to select the plane (G16, G17, G18 or G19) where the canned cycle will be executed. This way, the cycles may be executed in any of the three planes.

When selecting G17, G18 or G19, the three boxes are automatically filled in with the names of the corresponding axes. Also, the main view highlights the selected plane.

When selecting G16, the user can write the names of the axes in the boxes as he wishes. In this case, the main drawing does not highlight any plane.

If there are only XYZ axes, the selection icon does not show the option for free configuration (G16).

If a block is programmed with a change of plane; from then on, all the milling cycles may be executed in the new plane.

When turning the CNC off and back on, it loses the plane it was working with and the work plane is the one indicated by machine parameter IPLANE (XY or ZX).



Icon that serves to indicate the plane active in the cycle when the selected plane does not correspond with the plane indicated by general machine parameter IPLANE (P11). This icon will only be shown before pressing [START], after pressing [ESC].

4.

OPERATING IN ISO MODE
Programming assistance

FAGOR 

FAGOR AUTOMATION

CNC 8055
CNC 8055i

·MC· OPTION
SOFT: V02.2X

4.

OPERATING IN ISO MODE

Programming assistance



FAGOR AUTOMATION

CNC 8055
CNC 8055i

·MC· OPTION
SOFT: V02.2X

Part-programs may be edited, simulated and executed.

Each one of these programs is made up by concatenating simple operations or cycles and/or blocks edited in ISO code. Chapter ["3 Working with operations or cycles"](#) describes how to edit or define those operations or cycles.

This chapter indicates how to operate with those part-programs through the following sections and sub-sections.

- List of saved programs.
- Seeing the contents of a program.
- Editing a new part-program.
- Saving an ISO block or a cycle.
- Deleting a new part program.
- Copying a part-program into another one.
- Modifying a part-program.
- Managing programs using the explorer

5.1 List of saved programs



Press [P.PROG] to access the list of saved part-programs.

It is not possible to access the list of part-programs directly if the "Tool calibration" mode is selected. First, quit this mode; in other words, first press [ESC] and then [P.PROG].

The CNC will display the following information:

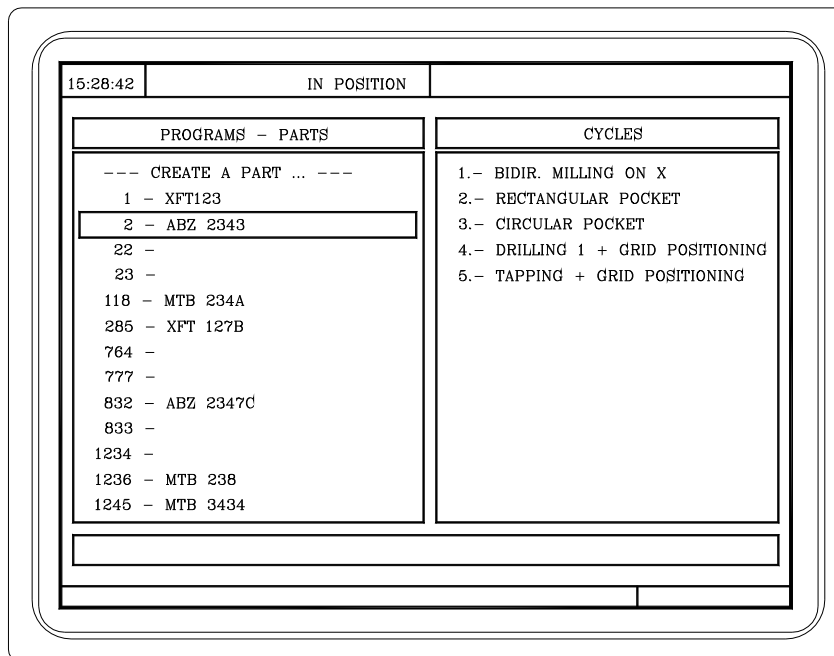

Press one of these keys to exit the directory or list of part-programs:



List of part-programs.

The left side shows the list of part-programs that are saved in the CNC's memory. Use the [↑][↓] keys to move the pointer over the list of programs. Use the [SHIFT][↑] y [SHIFT][↓] keys to scroll a page at a time.

It is possible to select the program by typing its number directly. If the desired program does not exist, the cursor will go to the nearest previous one. For example, to find program number 123, press the keystroke sequence [1], [2] and [3]. The time interval between keystrokes must be shorter than 1.5 seconds. A longer interval starts a new sequence.

Cycles that make up the part-program.

The right column shows the cycles and/or blocks edited in ISO code that make up the part. Once the list of programs has been selected, the following operations are possible:

- Creating a new part-program.
- Seeing the contents of a part-program.
- Deleting a new part program.
- Copying a part-program into another one.
- Modifying a part-program.

5.

SAVING PROGRAMS

List of saved programs



CNC 8055
CNC 8055i

.MC- OPTION
SOFT: V02.2X

5.2 See the contents of a program

To see the contents of a part-program, select it on the left column using the pointer. To do that, use the [↑][↓] keys. The right column shows the cycles that make up the part.



When pressing [ENTER] or one of the [←][→] keys, the pointer switches to the right column. Now, the [↑][↓] keys may be used to move the pointer over the blocks or cycles that make up the part.



So, use the [↑][↓] keys to move up and down on each column and [←][→] keys to switch columns.

Once an operation has been selected, the following is possible:

- To see the operation in detail.
- To delete the operation.
- To move the operation to another position.
- To modify the operation.

5.

SAVING PROGRAMS
See the contents of a program

FAGOR 

FAGOR AUTOMATION

CNC 8055
CNC 8055i

·MC· OPTION
SOFT: V02.2X

5.2.1 Seeing one of the operations in detail



Once the desired operation has been selected using the pointer, press [RECALL]. The CNC will show all the data for that operation.

In this moment it is possible to:

- Simulate the operation. See chapter "[6 Execution and simulation](#)".
- Execute the operation. See chapter "[6 Execution and simulation](#)".
- To modify the operation.
- Save the operation. Replacing the previous one or inserting it as a new one.

5.

SAVING PROGRAMS

See the contents of a program



FAGOR AUTOMATION

CNC 8055
CNC 8055i

·MC· OPTION
SOFT: V02.2X

5.3 Edit a new part-program

To edit a new program, proceed as follows:



1. Press [P.PROG] to access the list of part-programs stored.
2. Select, with the pointer, the option "Creating new part" on the left column.
3. Press the [P.PROG] key. The bottom of the screen will request the number to be assigned to the new part-program and it will offer the first one available.



4. Enter the number of the desired program and press [ENTER].
It must be a number between 1 and 899999. Both included.
5. The CNC requests the comment to be associated with the part-program.
It is not necessary to associate a comment.



6. Press the [ENTER] or [ESC].
The CNC includes the new part-program in the list (left column).

From this moment on, all the desired operations may be saved in the desired order.

5.

SAVING PROGRAMS
Edit a new part-program

FAGOR 

FAGOR AUTOMATION

CNC 8055
CNC 8055i

·MC· OPTION
SOFT: V02.2X

5.4 Saving an ISO block or a cycle

The block or cycle may be added at the end of the program, after the last operation or insert it between 2 existing operations.

To save the block or cycle, proceed as follows:

1. Define the desired block or cycle assigning the relevant data to it.
2. Press [P.PROG] to access the list of part-programs stored.
3. Select, with the pointer, the desired program number on the left column and switch over to the right column.
4. Place the pointer on the operation after which the block or cycle is to be saved and press [ENTER].

Example:

Current program	Desired program
Bidirectional surface milling in X	Bidirectional surface milling in X
Rectangular pocket	Rectangular pocket
Circular pocket	Circular pocket
	Drilling 1 + linear positioning
Drilling 1 + grid pattern positioning	Drilling 1 + grid pattern positioning
Threading + Grid pattern positioning	Threading + Grid pattern positioning
	Profile 1

To insert the "Drilling 1 + linear positioning" operation, once the operation has been defined, place the pointer on the "Circular pocket" operation and press [ENTER].

To insert the "Profile 1" operation, once the operation has been defined, place the pointer on the last operation "Threading + Grid pattern positioning" operation and press [ENTER].

5.

SAVING PROGRAMS
 Saving an ISO block or a cycle



FAGOR AUTOMATION

CNC 8055
CNC 8055i

·MC· OPTION
 SOFT: V02.2X

5.5 Delete a new part program

To delete a part-program, proceed as follows:

1. Press [P.PROG] to access the list of part-programs stored.
2. Select, with the pointer, the part-program to be deleted from the left column.



3. Press [CLEAR].

The bottom of the screen will show a message requesting confirmation of the deleting operation.

- If [ENTER] is pressed, the CNC will delete the selected program and will update the list of saved programs.
- If [ESC] is pressed, the program will not be deleted and it will quit deleting operation.

5.

SAVING PROGRAMS
Delete a new part program

FAGOR 

FAGOR AUTOMATION

CNC 8055
CNC 8055i

·MC· OPTION
SOFT: V02.2X

5.6 Copying a part-program into another one

To copy a part-program into another one, proceed as follows:

1. Press [P.PROG] to access the list of part-programs stored.
2. Select, with the pointer, the part-program to be copied from the left column.
3. Press the [P.PROG] key.
The bottom of the screen will show a message requesting the number to be assigned to the copy.
4. Enter the number of the desired program and press [ENTER].
It must be a number between 1 and 899999. Both included.
5. If there is already a part-program with that number, the bottom of the screen will show a message asking to either replace it or cancel the operation?
If [ENTER] is pressed, the CNC will request a new program. If [ESC] is pressed, the CNC will not delete the current program and will copy the program.
6. The CNC requests the comment to be associated with the new part-program (the copy).
It is not necessary to associate a comment.
7. Press the [ENTER] or [ESC]. The CNC updates the list of saved part-programs.

5.

SAVING PROGRAMS

Copying a part-program into another one



FAGOR AUTOMATION

CNC 8055
CNC 8055i

·MC· OPTION
SOFT: V02.2X

5.7 Modify a part-program

To modify a part-program, proceed as follows:

1. Press [P.PROG] to access the list of part-programs stored.
2. Select, with the pointer, the part-program to be modified from the left column.

Once the program has been selected, the following operations are possible:

- To delete an operation.
- To move an operation to another position.
- To add or insert a new operation.
- To modify an existing operation.

5.

SAVING PROGRAMS
Modify a part-program

FAGOR 

FAGOR AUTOMATION

CNC 8055
CNC 8055i

·MC· OPTION
SOFT: V02.2X

5.7.1 Delete an operation

To delete an operation, proceed as follows:

1. Select, with the pointer, the operation to be deleted from the right column.
2. Press [CLEAR].

The bottom of the screen will show a message requesting confirmation of the deleting operation.

- If [ENTER] is pressed, the CNC will delete the selected operation and will update the right column.
- If [ESC] is pressed, the operation will not be deleted and it will quit deleting operation.

5.

SAVING PROGRAMS
Modify a part-program



FAGOR AUTOMATION

CNC 8055
CNC 8055i

·MC· OPTION
SOFT: V02.2X

5.7.2 Add or insert a new operation

To add or insert an operation follow the same steps as for saving an operation.

1. Define the desired block or cycle assigning the relevant data to it.
2. Press [P.PROG] to access the list of part-programs stored.
3. Place the pointer on the operation after which the block or cycle is to be saved and press [ENTER].

5.

SAVING PROGRAMS
Modify a part-program

FAGOR 

FAGOR AUTOMATION

CNC 8055
CNC 8055i

·MC· OPTION
SOFT: V02.2X

5.7.3 Move an operation to another position

To move an operation to another position, proceed as follows:

1. Select, with the pointer, the operation to be moved from the right column.



2. Press the two-color key.

The CNC will highlight that operation.

3. Place the cursor on the operation after which the operation is to be placed and press [ENTER].

Example:

Current program	Desired program
Bidirectional surface milling in X	Bidirectional surface milling in X
Rectangular pocket	Circular pocket
Circular pocket	Drilling 1 + linear positioning
Drilling 1 + linear positioning	Drilling 1 + grid pattern positioning
Drilling 1 + grid pattern positioning	Threading + Grid pattern positioning
Threading + Grid pattern positioning	Rectangular pocket
Profile 1	Profile 1

Select the "Rectangular pocket" operation and press the two-color key. Then position the cursor on the "Threading + Grid pattern positioning" operation and press [ENTER].

5.

SAVING PROGRAMS
Modify a part-program



FAGOR AUTOMATION

CNC 8055
CNC 8055i

·MC· OPTION
SOFT: V02.2X

5.7.4 Modify an existing operation

To modify an operation, proceed as follows:

1. Select, with the pointer, the block or cycle to be modified from the right column.
2. Press the [RECALL] key.
The CNC will show the editing page for that operation.
3. Modify all the desired data.

To save the modified operation, proceed as follows:

1. Press [P.PROG] to access the list of part-programs stored.
The CNC shows the pointer on the same operation. To select another position, use the [↑][↓] keys; the new operation will be inserted after the selected one.
2. Press the [ENTER] key.

To place the modified operation in its previous location, the CNC will show a message asking to either replace the previous operation or keep it inserting the new one after it.

The following example modifies the "rectangular pocket" operation.

Current program	Option "Replace"	Option "Insert"
1.- Rectangular pocket	1.- Rectangular pocket	1.- Rectangular pocket
2.- Circular pocket	2.- Circular pocket	2.- Rectangular pocket
		3.- Circular pocket



It is possible to select an existing operation, modify it and then insert it in another position and even in another part-program.

5.

SAVING PROGRAMS
Modify a part-program

5.8 Managing programs using the explorer

Windows Explorer may be accessed from the PPROG screen by placing the cursor in the "user programs" area and pressing [RECALL]. Pressing the [ESC] key returns to the PPROG screen.

Accessing the explorer displays a window divided in two areas (left panel and right panel) as shown in the next figure:

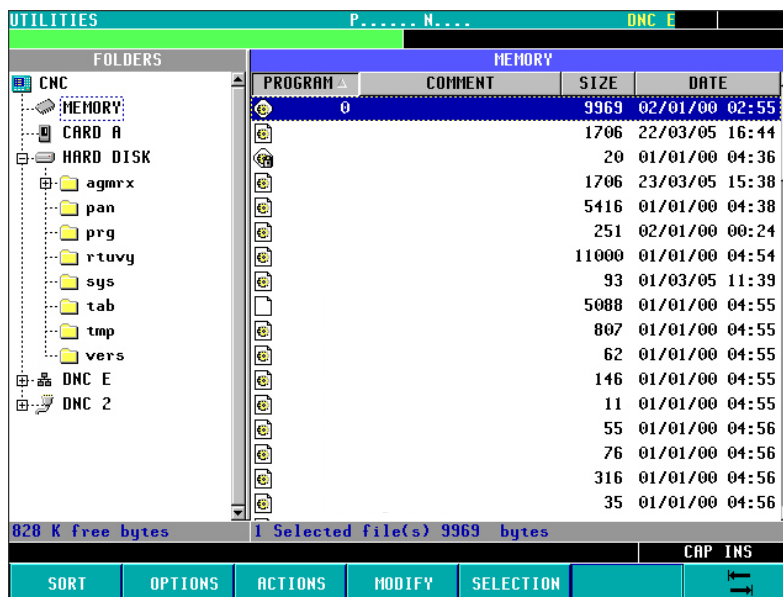

Once in the explorer, it will be possible to select any program of the Ram memory or hard disk (KeyCF) to edit it or execute it. When selecting the hard disk (KeyCF), the CNC will select the PRG folder automatically because it is the only folder where programs may be executed.



When selecting programs of the hard disk (KeyCF), only programs from the PRG folder may be selected.

When returning from the explorer to the PPROG screen with a different device, the CNC will display a message warning that the device has been changed and requesting confirmation.

Once out of the explorer, the CNC will show an indicator of the device that has been selected. This indicator will appear to the left of the selected program.



The subroutines and profiles defined in the profile cycles (the profiles defined in the cycle as well as the associated profile programs) must be in user RAM memory although the call to the cycle may be in a program of the hard disk (KeyCF).

Programs contained in USB or in DNC (infinite program) can be neither edited nor executed. The selected device will be maintained even after turning the CNC off or after a Shift/Reset.

The simulation may be used to graphically show a part-program or an operation with the data used to define it. This way, the simulation may be used to check the part-program or the operation before executing it or saving it and, therefore, correct or modify its data.



It is possible to execute or simulate a part-program or any operation. The simulation or execution may be done from beginning to end or step by step by pressing the [SINGLE] key.

It is possible to simulate or execute:

- An operation or Cycle.
- A part-program.
- An operation saved as part of a part-program.

Selecting a program for simulation or execution

When selecting a part-program or operation saved as part of a part-program for simulation or execution, the CNC selects that part-program and shows it highlighted next to the green "start" symbol in the top center window.

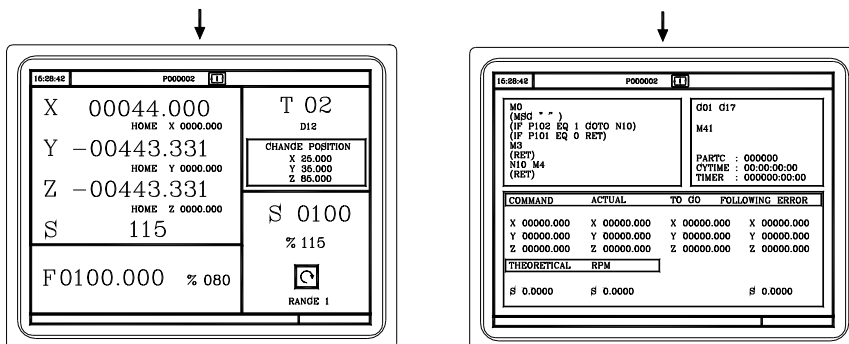

When the top center window shows the part-program selected next to the green "start" symbol, the CNC acts as follows:

- If [START] is pressed, the CNC executes the part-program that is selected.
- If [CLEAR] is pressed, the CNC de-selects the part-program and removes it from the top center window.



FAGOR AUTOMATION

CNC 8055
CNC 8055i

·MC· OPTION
SOFT: V02.2X

6.1 Simulating or executing an operation or cycle

All the operations or cycles have 2 work modes; execution and editing.

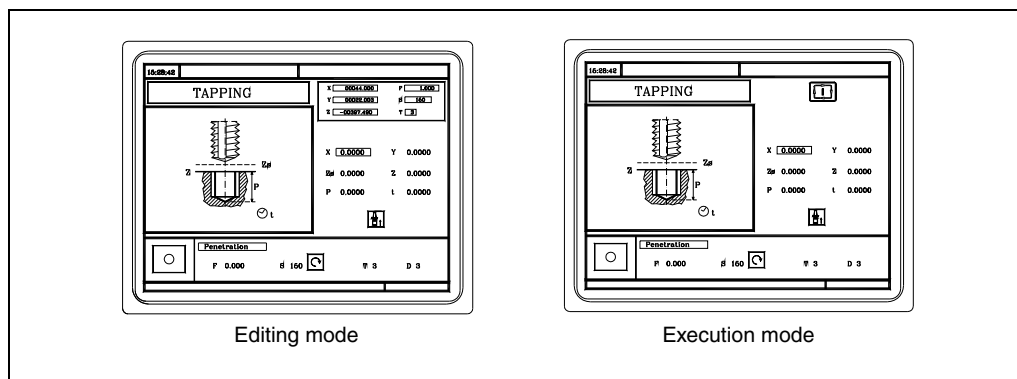

Simulation



The operation or cycle may be simulated in both work modes. To do that, press the [GRAPHICS] key. The CNC shows the graphic screen of the M model.

Execution

An operation or cycle can only be executed in the cycle execution mode.

The operation or cycle cannot be executed when the cycle editing mode is selected. Press [ESC] to quit the editing mode and switch to execution mode.



Press [START] to execute an operation or cycle.

6.2 Simulating or executing a part-program

Proceed as follows to simulate or execute a part-program:

1. Press [P.PROG] to access the list of part-programs stored.
2. Select on the left column the program to be simulated or executed.

Press [GRAPHICS] to simulate the part-program and [START] to execute it. When executing a program, the CNC executes the initial subroutine 9998 and the final subroutine 9999.

If an error occurs in a cycle during simulation or execution, when accessing the list of programs again, the cursor will be placed on the cycle that came up with the error. When program 999998 is displayed on the screen or the error is not an execution error, the cursor will go to the beginning or to the end of the program depending on its length.

6.

EXECUTION AND SIMULATION
Simulating or executing a part-program

FAGOR 

FAGOR AUTOMATION

CNC 8055
CNC 8055i

·MC· OPTION
SOFT: V02.2X

6.2.1 Simulating or executing a portion of a part-program

Proceed as follows to simulate or execute a portion of a part-program:

1. Press [P.PROG] to access the list of part-programs stored.
2. Select the program from the left column and the operation (on the right column) from which to begin executing or simulating the part program.

Press [GRAPHICS] to simulate the selected portion and [START] to execute it. When executing a portion of a program, the CNC does not execute the initial subroutine 9998, but it executes the final subroutine 9999. If the program is executed from the first operation on, it executes both subroutines.

6.

EXECUTION AND SIMULATION

Simulating or executing a part-program



FAGOR AUTOMATION

CNC 8055
CNC 8055i

·MC· OPTION
SOFT: V02.2X

6.3 Simulating or executing an operation that has been saved

Proceed as follows to simulate or execute an operation that has been saved as a part of program:

1. Press [P.PROG] to access the list of part-programs stored.
2. Select the program that contains it from the left column and the operation to be simulated or executed from the right column.
3. Press the [RECALL] key.

Press [GRAPHICS] to simulate the operation and [START] to execute it.

6.

EXECUTION AND SIMULATION

Simulating or executing an operation that has been saved

FAGOR 

FAGOR AUTOMATION

CNC 8055
CNC 8055i

·MC· OPTION
SOFT: V02.2X

6.4 Execution mode



When pressing [START] to execute an operation or part-program, the CNC shows the standard screen of the MC mode.

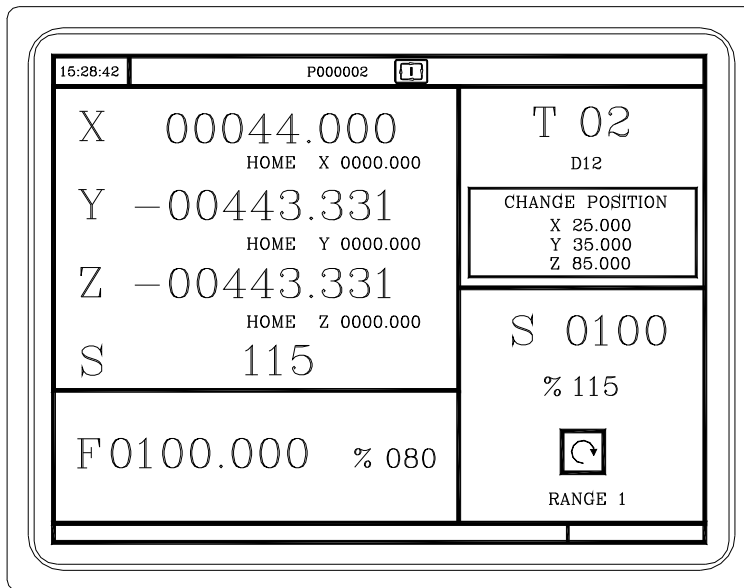

When pressing the two-color key, the CNC shows the special screen of the MC mode.

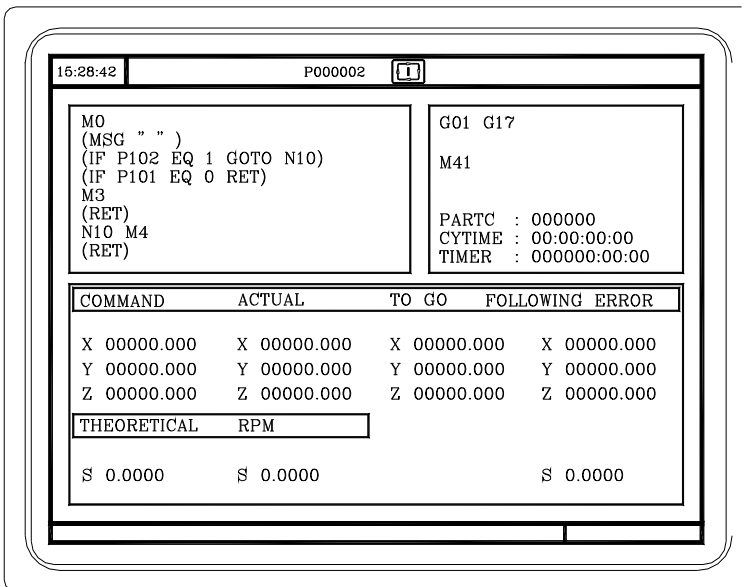

During execution, both screens show (in the top center window) the number of the program and the number of the cycle being executed. However, when detecting an RPT or GOTO instruction, the cycle number will disappear.



Once the operation or part has been selected, it may be executed as often as desired; to do that, once the execution has finished, pressed the [START] again.



To interrupt the execution, press [STOP]. Once the execution has been interrupted, a tool change may be done. See "6.4.1 Tool inspection" on page 153.



While executing an operation or a part, the [GRAPHICS] key may be pressed to access the graphics display mode.

6.4.1 Tool inspection

The PLC mark M5050 "TOOLINSP" determines when tool inspection is enabled.



TOOLINSP=0 Tool inspection is possible after pressing [STOP].

TOOLINSP=1 Pressing [STOP] interrupts the execution of the program. To move the axes and do a tool inspection, press the [T] key once the execution of the program has been interrupted.

Once tool inspection has been selected, it is possible:

- To move the axes to the tool change point.
- Select another tool.
- To modify the tool values.
- To resume program execution.

To move the axes to the tool change point.

To move the axes with the handwheels or the jog keypad to the point where the tool will be changed.

Select another tool.

The standard screen of the MC mode must be selected in order to be able to make a tool change.

Press the [T] key. The CNC highlights the tool number.



Type in the number of the tool to be selected and press [START] so the CNC selects the new tool. The CNC will manage the tool change.

Modifying the tool values (dimensions and geometry).



Press the key associated with tool calibration. The CNC shows the screen for tool calibration.

It is possible to modify the dimensions of the tool (offsets I, K to compensate for wear) or the values for tool geometry.

Press the [ESC] key to exit this screen and go back to the previous one (still in tool inspection).

Resuming program execution.



Press the [START] key to resume program execution. The CNC will reposition the tool by moving it to the point where tool inspection began.

There may be 2 cases; either only one axis moved or several did.

- Only one axis moved.
The CNC repositions it and resumes the execution.

- Several axes moved.

The CNC will show a window with the following options to choose the order the axes will be repositioned.

PLANE	The axes of the X-Y plane move at the same time.
Y-X	When moving the axes of the plane, the Y axis moves first and then the X.
X-Y	When moving the axes of the plane, the X axis moves first and then the Y.
Z	Move the Z axis.

For example, to move first the Z axis, then the Y and finally the X axis, select [Z] [Y-X].

6.5 Graphic representation



When the [GRAPHICS] key is pressed, the CNC displays the graphic representation page of the M model. To leave the graphic representation mode, press the [GRAPHICS] key or the [ESC] key.

During simulation, the top center window shows the number of the program and the number of the cycle being executed. However, when detecting an RPT or GOTO instruction, the cycle number will disappear.

The operating manual, M model, "Graphics" section of the "Execution / Simulation" chapter describes how to use the graphics display. However, here is a brief description of the softkeys.

Type of graphic

3D	It draws the part in three dimensions.
XY, XZ, YZ	They draw the part in the selected plane.
COMBINED VIEW	It divides the screen in four quadrants and draws the graph corresponding to each plane XY, XZ, YZ and the three-dimensional graph.
TOP VIEW	It draws a top view (XY plane) with different shades of gray that indicate the depth of the part. It also displays the XZ and YZ sections for the areas shown by the indicators of the top view (XY plane).
SOLID	It shows a three-dimensional block that will be "machined" as the part-program is being run.

Display area

With this option it is possible to re-define the display area by defining the maximum and minimum values for each axis.

Use the [▲][▼] keys to select the maximum and minimum values. Once all the data has been defined, press [ENTER].

When selecting a new display area, the CNC clears the screen and shows the axes or the part unmachined.



The display area cannot be changed while executing or simulating the part. If it is, interrupt the execution or simulation by pressing the [STOP] key.

Zoom

With this option, it is possible to enlarge or reduce the graphics display area.

It shows a window superimposed on the current graphics and another one over the drawing at the lower right-hand side of the screen. These new windows indicate the new display area being selected.

Use the [◀][▶][▲][▼] keys to move the window around, the softkeys "ZOOM+" "ZOOM-" to enlarge or shrink its size and press [ENTER] for those new values to be assumed.

6.

Every time a new display area is selected, the CNC keeps the current graphic representation. It does not delete it.



When pressing [START] to resume or re-start the execution or simulation, it deletes the current graphic representation and starts a new one with the new values.



The zoom function cannot be used while executing or simulating the part. If it is, interrupt the execution or simulation by pressing the [STOP] key.

Graphic parameters

- Simulation speed.

Select on the top right side of the screen the percentage of simulation speed to be applied.

Use the [←][→] keys to select the percentage and press [ENTER] for the CNC to assume that value.

- Tool path colors.

It only makes sense in line graphics (not in solid ones). It lets you choose the colors to represent rapid traverse, the tool path without compensation, the tool path with compensation and threading.

Use the [↑][↓] keys to select, on the right side of the screen, the type of path and use the s [←][→] keys to select the color to be applied.

Press [ENTER] for the CNC to assume those values.

- Colors of solid.

It only makes sense in solid graphics (not in line graphics). It lets you use the colors to represent the cutter, the part, the axes and the clamps.

Use the [←][→] keys to select, on the right side of the screen, the type of path and use the [↑][↓] keys to select the color to be applied.

Press [ENTER] for the CNC to assume those values.

Clear screen

When selecting this option, the CNC clears the screen and shows the axes or the part unmachined.



The screen cannot be cleared while executing or simulating the part. If it is, interrupt the simulation by pressing the [STOP] key.

Starting graphic simulation



Once the type of graphics, the display area, the graphic parameters, etc have been selected, press the [START] key to start graphic simulation.

During graphic simulation, the CNC takes into account the simulation speed and the position of the feedrate override switch (FEED 0%-120%).

When selecting a new simulation speed, the CNC applies 100% of it regardless of the position of the switch. Once the switch is turned, the CNC begins to apply the selected %.

To interrupt the simulation, press [STOP].



To quit the simulation mode, press either [GRAPHICS] or [ESC].

6.

EXECUTION AND SIMULATION
Graphic representation

FAGOR 

FAGOR AUTOMATION

CNC 8055
CNC 8055i

-MC- OPTION
SOFT: V02.2X

ISO

In the conversational mode of the CNC, it is possible to generate an ISO-coded program with some basic G functions as well as M and T functions from an operation (cycle) or on a part-program.

To enable this feature, set general machine parameter ISOSIMUL (P183) with a value other than zero. This parameter identifies the number of the ISO program generated in user RAM memory.

The program generated from the conversational program is an ISO-coded program created in RAM memory. This program may be later edited, copied or executed at the CNC itself.

To generate the ISO program, use the simulation in conversational mode through the "GRAPHICS" key. This can be done in a whole program on the PPROG screen or in any of the particular TC or MC cycles.

Once inside the graphic simulation screen, the ISO generation maybe selected using the <ISO> softkey. Then, pressing [CYCLE START] will generate the program defined by machine parameter ISOSIMUL (that will only contain ISO instructions) while it simulates it graphically.

When generating that program, parametric programming, rounding (G36), tangential entry (G37), tangential output (G38), chamfer (G39) and path tangent to previous path (G8) are resolved and generated only using G1, G2 and G3 blocks.

If the program already exists, it will be deleted without requesting confirmation. If the generated program exceeds the available user memory, the CNC will issue the corresponding error message, but it will keep in memory the portion of the ISO program generated so far.

Description of the functions used to generate an ISO-coded program:

The ISO-coded program is mainly generated to control axes. It provides information of the moving conditions and indications on feedrate using the following set of functions

- **G functions:** Motion preparatory functions to determine the geometry and work conditions.

Function	Meaning
G2 (G3) G6 X Y I J	In the circular interpolation, the center will be programmed with respect to the origin, not referred to the starting point of the circle.

Rigid tapping cycles G84 (mill) and G86 (lathe) only generate the equivalent ISO block.

- **F and S functions:** Functions to control the feedrate of the axes and the spindle turning speed.
- **T and D functions:** Tool control functions.

If the T function has an associated subroutine, the blocks of this subroutine are ignored when generating the program set by g.m.p. ISOSIMUL (P183).

- **M functions:** Complementary or auxiliary functions.

If the M functions have an associated subroutine, the blocks of this subroutine are ignored when generating the program set by g.m.p. ISOSIMUL (P183).

6.

EXECUTION AND SIMULATION
Graphic representation



FAGOR AUTOMATION

CNC 8055
CNC 8055i

·MC· OPTION
SOFT: V02.2X



6.



FAGOR AUTOMATION

CNC 8055
CNC 8055i

SOFT: V02.2x

6.



FAGOR AUTOMATION

CNC 8055
CNC 8055i

SOFT: V02.2X



FAGOR AUTOMATION

Fagor Automation S. Coop.

Bº San Andrés, 19 - Apdo. 144
E-20500 Arrasate-Mondragón, Spain

Tel: +34 943 719 200
+34 943 039 800

Fax: +34 943 791 712

E-mail: info@fagorautomation.es
www.fagorautomation.com

