

FAGOR AUTOMATION

MODULAR QUICK REFERENCE

Ref.1601

· *Original instructions* ·



FAGOR 

WARRANTY TERMS

INITIAL WARRANTY

All products manufactured or marketed by FAGOR carry a 12-month warranty for the end user.

In order to prevent the possibility of having the time period from the time a product leaves our warehouse until the end user actually receives it run against this 12-month warranty, the OEM or distributor must communicate to FAGOR the destination, identification and installation date of the machine by filling out the Warranty Form that comes with each product.

The starting date of the warranty for the user will be the one appearing as the installation date of the machine on the Warranty Form.

This system ensures the 12-month warranty period to the user.

FAGOR offers a 12-month period for the OEM or distributor for selling and installing the product. This means that the warranty starting date may be up to one year after the product has left our warehouse so long as the warranty control sheet has been sent back to us. This translates into the extension of warranty period to two years since the product left our warehouse.

If this sheet has not been sent to us, the warranty period ends 15 months from when the product left our warehouse.

FAGOR is committed to repairing or replacing its products from the time when the first such product was launched up to 8 years after such product has disappeared from the product catalog.

It is entirely up to FAGOR to determine whether a repair is to be considered under warranty.

EXCLUDING CLAUSES

The repair will take place at our facilities. Therefore, all shipping expenses as well as travelling expenses incurred by technical personnel are NOT under warranty even when the unit is under warranty.

This warranty will be applied so long as the equipment has been installed according to the instructions, it has not been mistreated or damaged by accident or negligence and has been handled by personnel authorized by FAGOR.

If once the service call or repair has been completed, the cause of the failure is not to be blamed the FAGOR product, the customer must cover all generated expenses according to current fees.

No other implicit or explicit warranty is covered and FAGOR AUTOMATION shall not be held responsible, under any circumstances, of the damage which could be originated.

SERVICE CONTRACTS

Service and Maintenance Contracts are available for the customer within the warranty period as well as outside of it.

SAFETY CONDITIONS

Read the following safety instructions in order to prevent harming people and damage to this product or to the products connected to it. FAGOR AUTOMATION shall not be held responsible of any physical or material damage originated from not complying with these basic safety rules.

MANDATORY. Always use the latest [man_dds_hard.pdf](#) manual reference, available on FAGOR's corporate website. <http://www.fagorautomation.com>.

To obtain detailed information regarding the safety system of the DDS system, read the section on **SAFETY CONDITIONS** of the [man_dds_hard.pdf](#) manual.

Refer to **CHAPTER 9** of the [man_dds_hard.pdf](#) manual for any information on **SAFETY FUNCTIONS** of the DDS system.



WARNING. Do not access the inside of this unit.

Only personnel authorized by Fagor Automation may access the interior of this unit.

Do not handle the connectors while the unit is connected to mains

Before handling the connectors (mains, moving power, feedback, etc.) make sure that the unit is not connected to mains.

Use the right mains cables

In order to avoid risks, use only the mains cables recommended for this unit.

Avoid electrical shocks

To avoid electric shocks and the risk of fire, do not apply electrical voltage beyond the range indicated in this manual.

Ground connection

In order to avoid electrical shocks, connect the ground terminal of this unit to the main ground point. Also, before connecting the inputs and outputs, make sure that the ground connection has been done.

Before turning the unit on, make sure that it is connected to ground

In order to avoid electrical shocks, make sure that it has been connected to ground.

Ambient conditions

Respect the limits of temperature and relative humidity indicated in the technical characteristics of this manual.

Do not operate this unit in explosive environments

In order to avoid risks, harm or damages, do not work in explosive environments.

Working environment

These electrical units are ready to be used in industrial environments and comply with the current Directives and regulations of the European Community.

Electrical cabinet. Diagrams

DANGER. The diagrams of this manual do not meet the **European Machinery Directive 2006/42/EC**. Complying with the European Machinery Directive usually requires PL d or SIL 2 (milling machines and lathes). The AXD/SPD reaches PL d or SIL 2 (see models in the Declaration of Conformity). An external safety controller PL d or SIL 2 is necessary as well as bearing in mind the concepts in **CHAPTER 9. SAFETY FUNCTIONS** of the [man_dds_hard.pdf](#).



DUAL-USE products

Products manufactured by Fagor Automation S. Coop. included on the list of dual-use products according to regulation (UE) Nr 1382/2014. Their product identification includes the text **MDU** and require an export license depending on destination.

SYNCHRONOUS MOTORS

ELECTRICAL CHARACTERISTICS

Electrical limitations for a synchronous motor

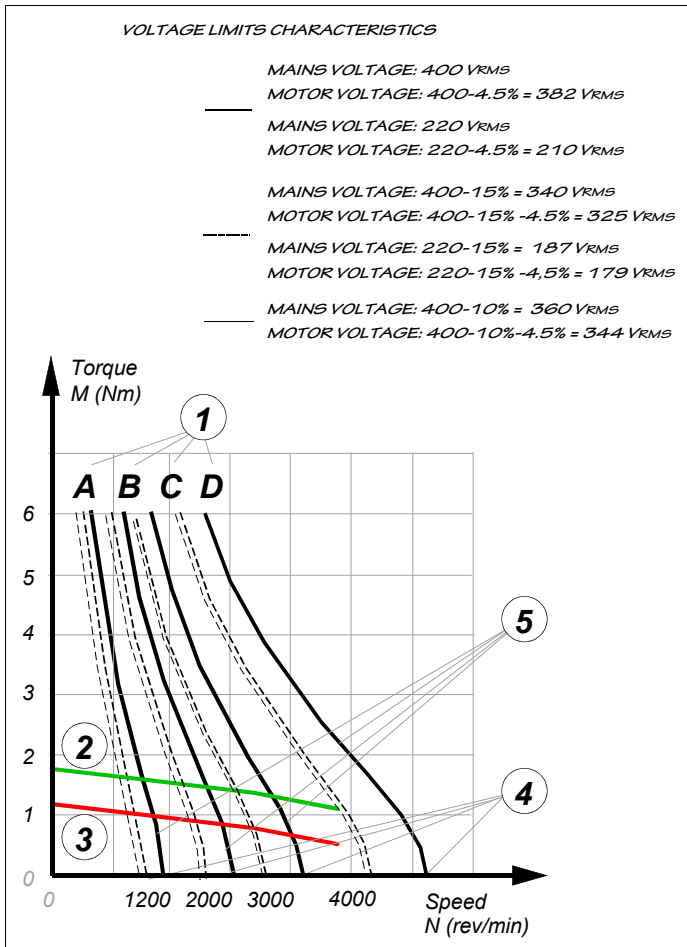

1. Curves for torque limitation by voltage depending on type of stator winding.
2. Curve for thermal torque limitation in continuous duty S1 (100 K) with fan where $\Delta T=100$ K at the winding.
3. Curve for thermal torque limitation in continuous duty S1 (100 K) without fan where $\Delta T=100$ K at the winding.
4. Maximum turning speed limitation (in voltage) N_{max} .
5. Voltage saturation curves.



WARNING. Note that this data is valid for ambient temperature or an average cooling temperature of 40°C (104°F).

Electrical limitations for a motor-drive combination

ZONE 1. Is the permanent duty area (S1 duty) and it is delimited by the stall motor torque and the torque at rated speed.

ZONE 2. Is the intermittent duty zone.

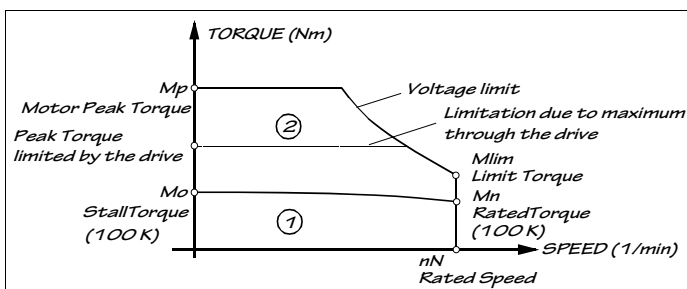

DEFINITIONS

Mo. Stall torque. Maximum torque that the motor can supply when the rotor is locked and is thermally limited by the temperature increase at the stator winding ($\Delta T=100$ K). This torque is available for a zero rotor turning speed for an unlimited time period. The stall torque M_o is always greater than the rated torque M_{nom} .

Io. Stall current. Current circulating through each phase of the stator winding required to generate the stall torque M_o . This current can circulate for an unlimited time.

Mn. Rated torque. Torque that the motor can supply continuously at its rated speed and is thermally limited by the temperature increase at the stator winding ($\Delta T=100$ K).

In. Rated current. Current circulating through each phase of the stator winding required to generate the rated torque M_{rated} .

Pn. Rated power. Power available at rated speed and rated torque. Its value is given in watts by expression: $M_n \cdot n_N / 9550$ where P_n (in kW), M_n (in Nm) and n_N (in rev/min).

Nmax. Maximum speed. Rotor turning speed limitation due to electrical restrictions (voltage limits). Note that the maximum value for this speed is shown in the torque-speed curves given in this manual.

Mp. Peak torque. Maximum torque (limited by current) generated by the maximum I_p current allowed at zero speed. It is available for dynamic operations such as accelerations, ... The value of this current is always limited by the control parameter (CP20) in face of the risk of exceeding the destruction temperature of the insulation of the stator winding.

tac. Acceleration time. Time it takes the motor to accelerate from zero speed to its rated speed with maximum torque.

kt. Torque constant. Torque generated according to the current supplied. Its value may be calculated with the division of the stall torque by the stall current (M_o/I_o).

nN. Rated turning speed.

Pcal. Power value given by the expression: $M_o \cdot n_N / 9550$ where P_{cal} (in kW), M_o (in Nm) and n_N (in rev/min).

R. Value of the resistance of a phase at an ambient temperature of 20°C (68°F). The stator winding has a star configuration.

L. Value of the inductance corresponding to a phase when using three-phase power supply. The stator winding has a star configuration.

J. Rotor moment of inertia.

P. Mass.

FXM 1/3/5/7 MOTORS

GENERAL CHARACTERISTICS

These motors have been manufactured in accordance with the European regulations EN 60204-1 and EN 60034 as instructed by the European Directive 2006/95/EC on Low Voltage (LVD).

Excitation	Permanent rare earth magnets (SmCo)
Temperature sensor	Thermistor PTC
Shaft end	Cylindrical with keyway Optionally: without keyway
Mounting	Face flange
Mounting methods	IM B5 - IM V1 - IM V3 (as recommended by IEC-34-3-72)
Mechanical tolerances	Normal class N (meets IEC-72/1971)
Balancing	Class N, (class R optional) (DIN 45665) (balanced with the wole key)
Roller bearing's life	20.000 hours
Type of winding	F winding (220 V AC) A winding (400 V AC)
Pairs of poles	P=3
Noise	DIN 45653
Vibration resistance	Withstands 1G along the shaft and 3G sideways (take G=9.81 m/s ²)
Stator winding insulation	Heating class F (150°C/302°F)
Insulation resistance	500 V DC, 10 MΩ or greater
Dielectric rigidity	1500 V AC, 1 min.
Degree of protection	Overall: IP 64 standard, IP 54 with fan Axis: IP 64 standard, IP 65 with oil seal
Storage temperature	-20°C/80°C (-4°F/176°F)
Permitted ambient temp.	0°C/40°C (32°F/104°F)
Working ambient humidity	From 20 % to 80 % (non condensing)
Brake	Optional on all models
Feedback	Sinewave encoder Incremental TTL encoder

Sinusoidal encoder. FXM models with A and F winding.

Incremental TTL encoder. FXM models with F winding.



WARNING.

The "F class" insulation on the motor keeps its dielectric properties as long as the temperature does not exceed 150°C (302°F) for a cooling temperature of 40°C (104 °F).

TEMPERATURE SENSOR

FXM motors have a thermistor PTC (positive temperature coefficient) sensitive in a temperature range between 130°C (266°F) and 160°C (320°F).

Sensor type	PTC thermistor (triple)
Resistance at 145°C (293°F)	550 Ω
Resistance at 155°C (311°F)	1330 Ω
Sensor connection	Feedback cable

RESISTANCE/TEMPERATURE CHARACTERISTICS OF «PTC» THERMISTOR

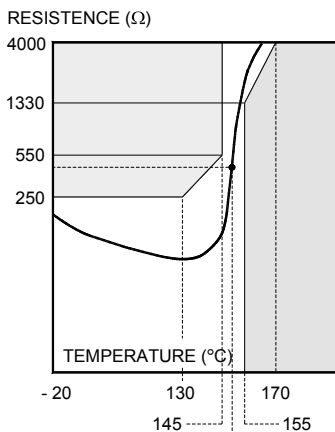

The following figure shows the resistance of the sensor as a function of the ambient temperature (average values).

The wires of the temperature sensor are included in the feedback cable.

OUTSIDE APPEARANCE

The following figure shows the location of the connectors for power and motor feedback connection:

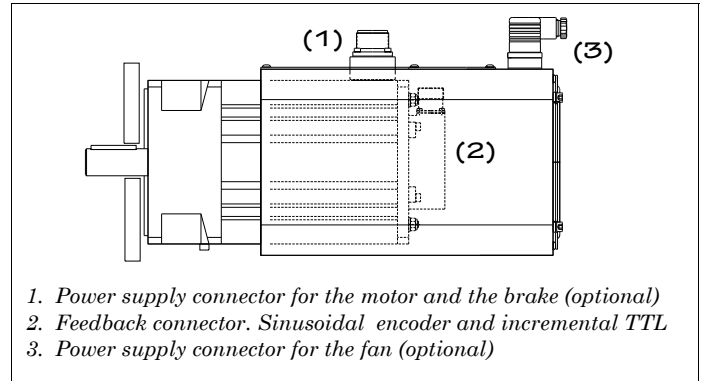

CHARACTERISTICS CURVES.

NON-VENTILATED FXM SERIES AT 400 V AC

FXM1 series and FXM3 series

—————	400 V
-----	400 V-15%
(A)	2000 min ⁻¹ , (B) 3000 min ⁻¹ , (C) 4000 min ⁻¹

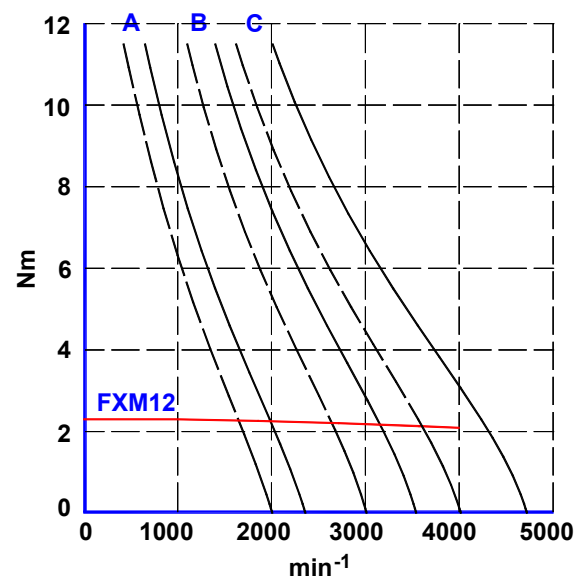
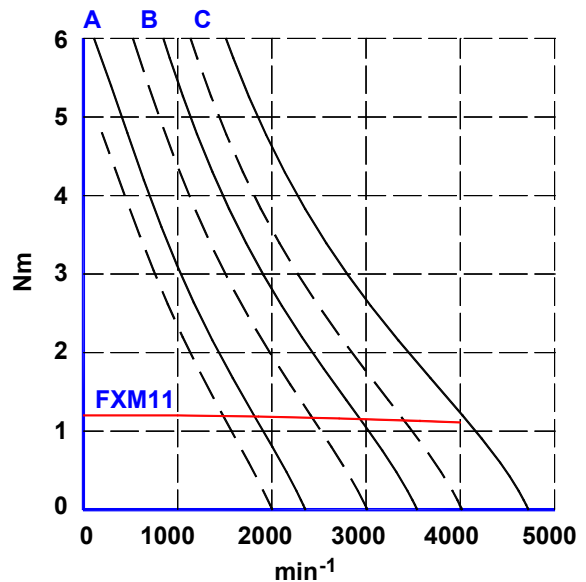

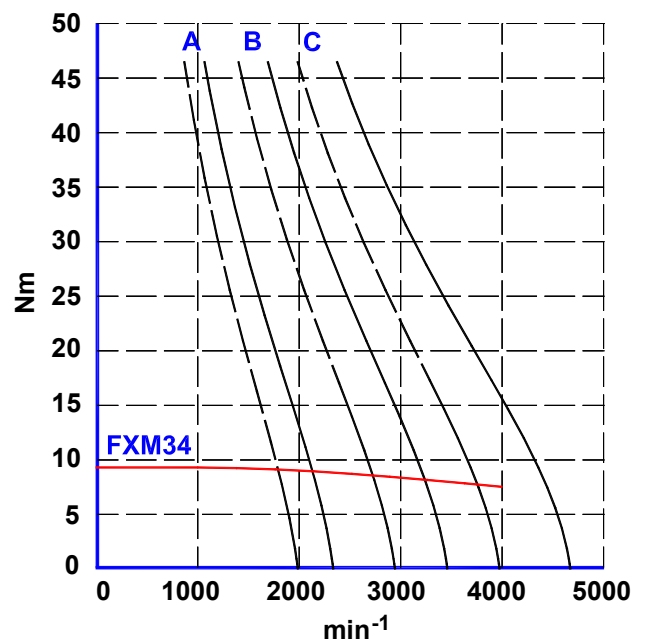
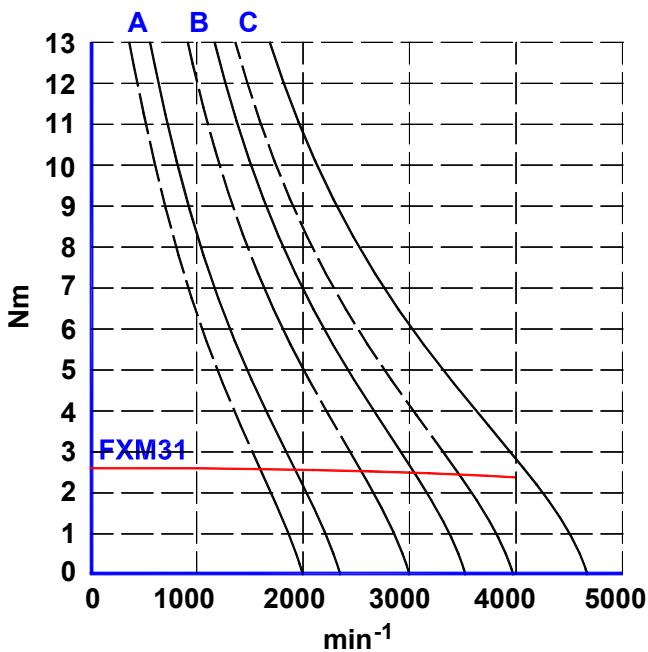
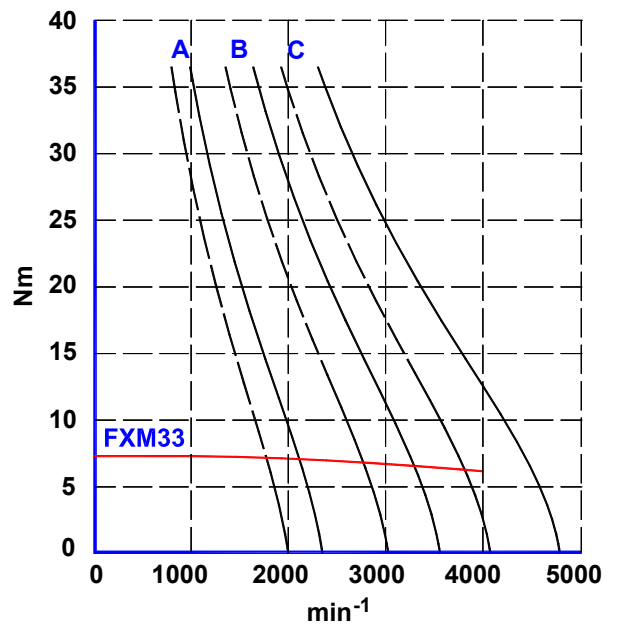
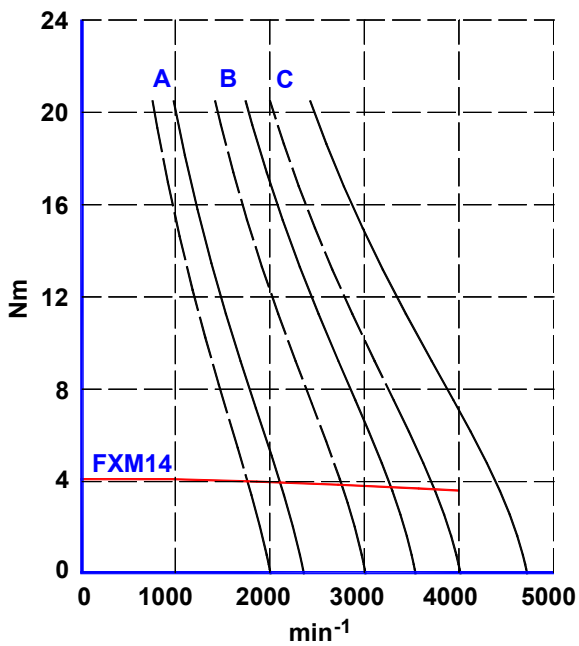
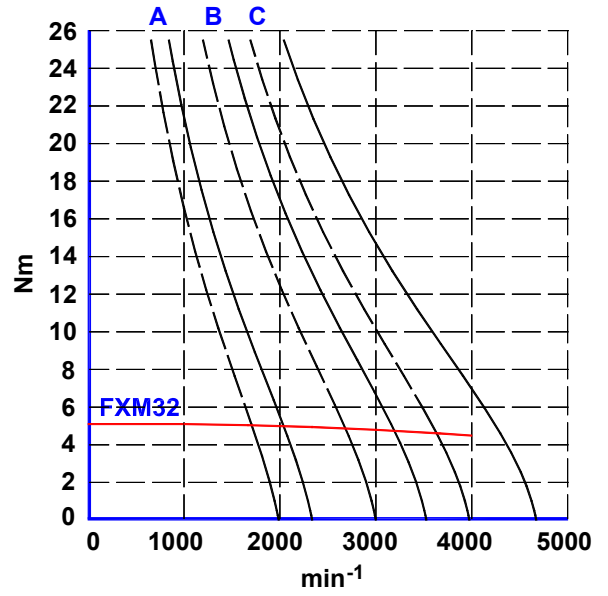
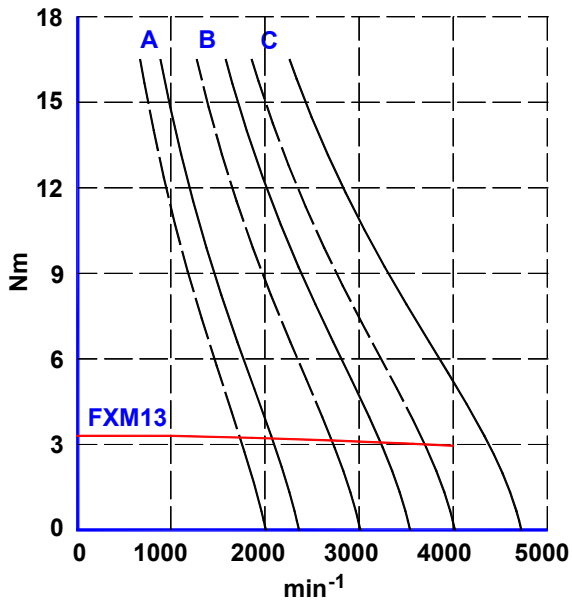

FXM5 series and FXM7 series

—————	400 V
-----	400 V-15%
(A) 1200 min ⁻¹ , (B) 2000 min ⁻¹ , (C) 3000 min ⁻¹ , (D) 4000 min ⁻¹	

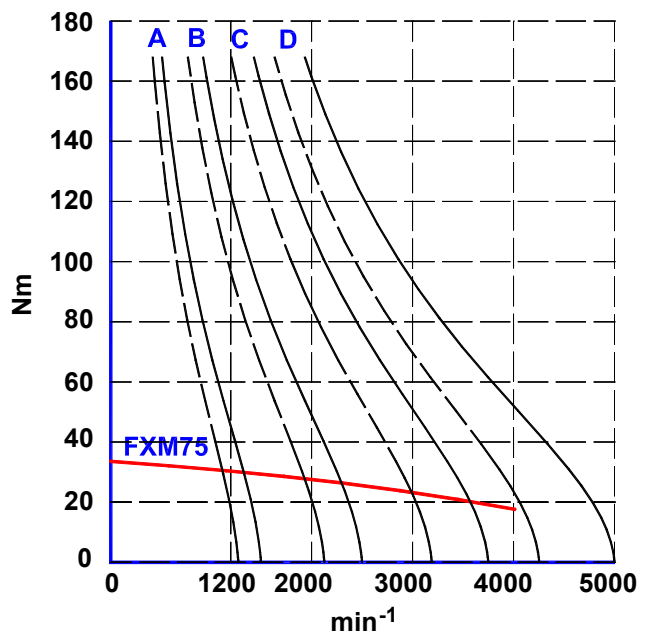
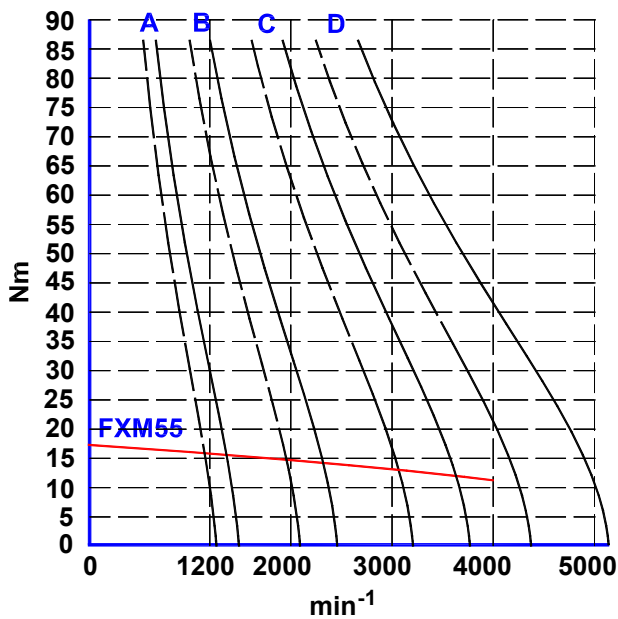
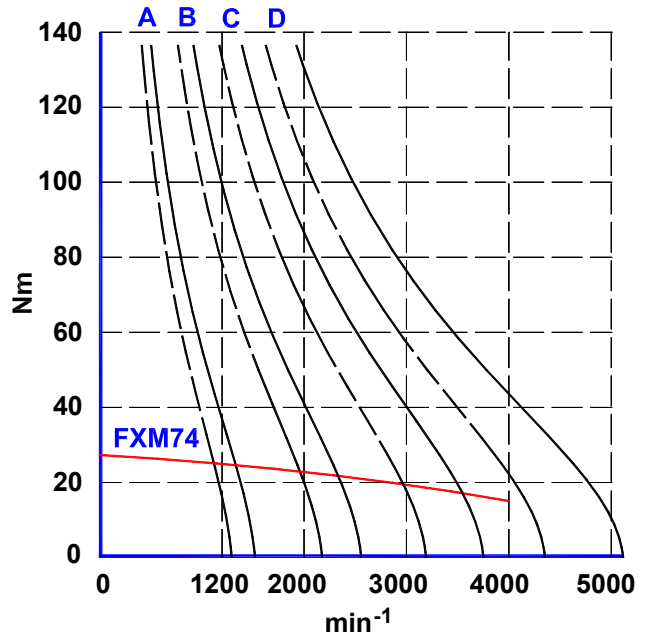
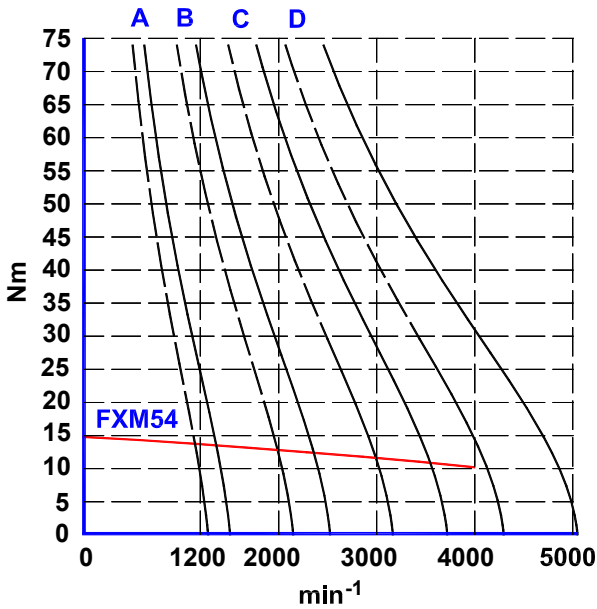
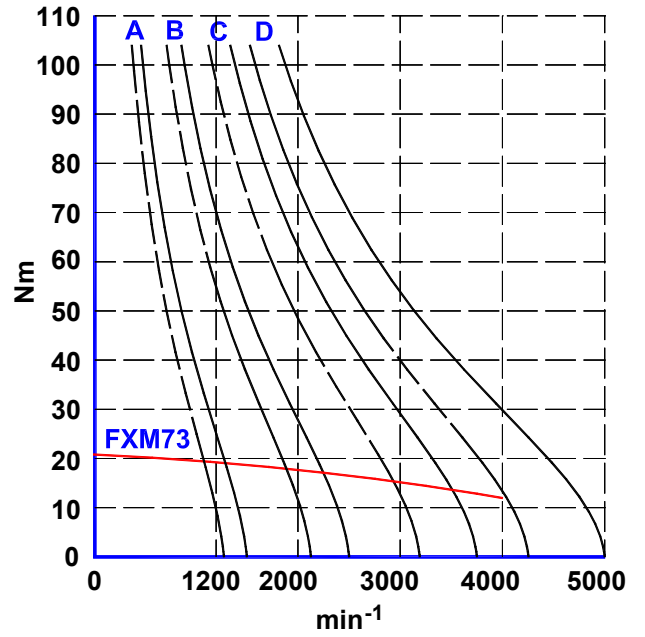
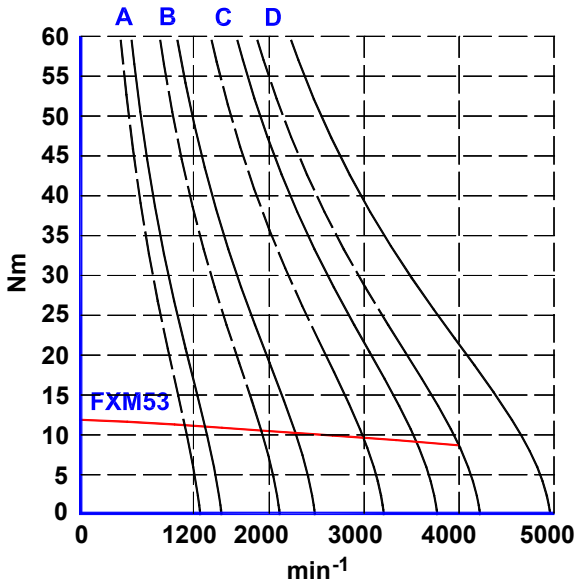

**CHARACTERISTICS CURVES.
VENTILATED FXM SERIES AT 400 V AC**

FXM5/V series and FXM7/V series

—————	400 V
- - - - -	400 V-15%
(A)	1200 min ⁻¹ , (B) 2000 min ⁻¹ , (C) 3000 min ⁻¹ , (D) 4000 min ⁻¹

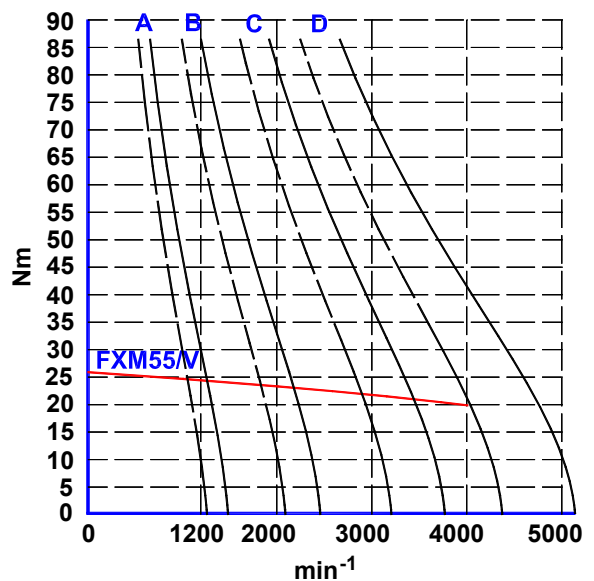
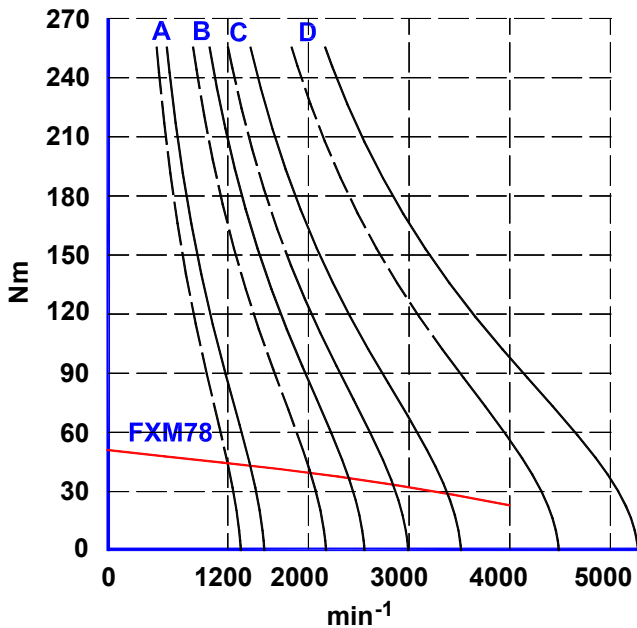
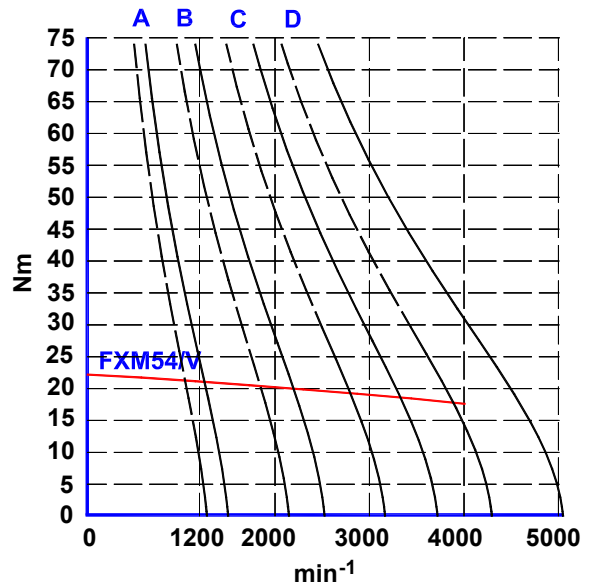
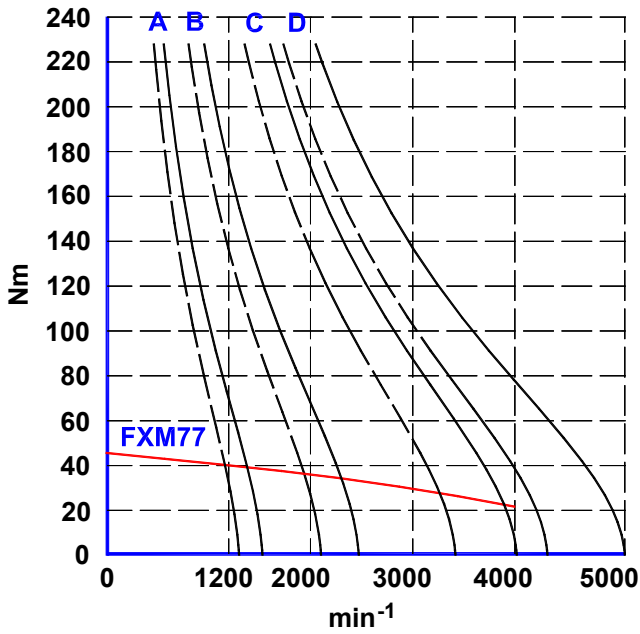
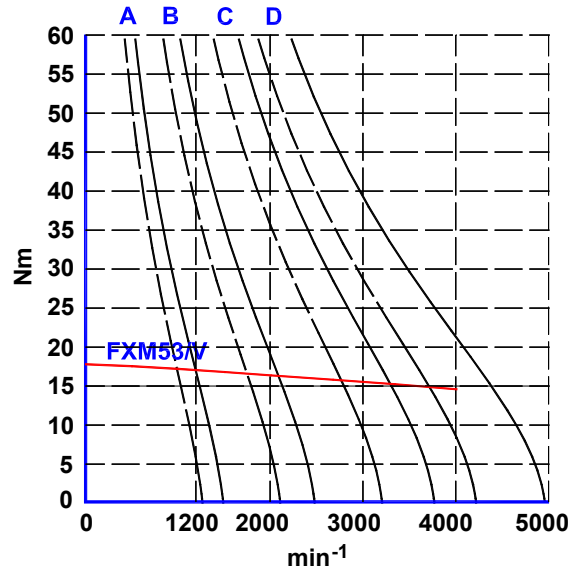
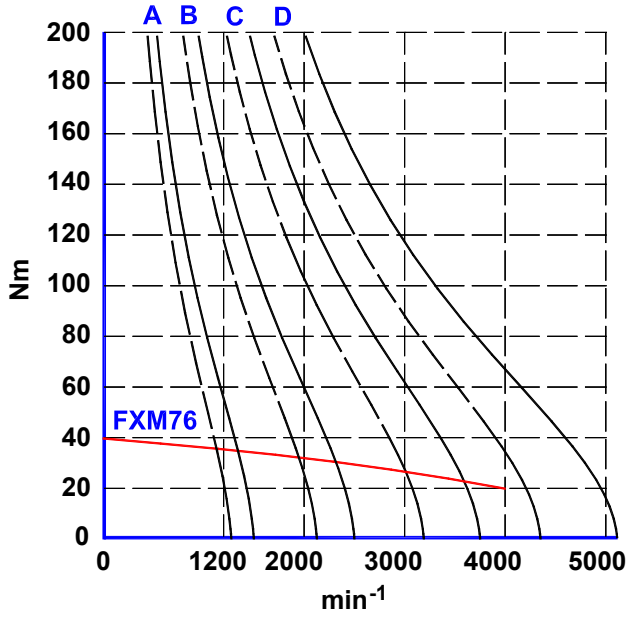

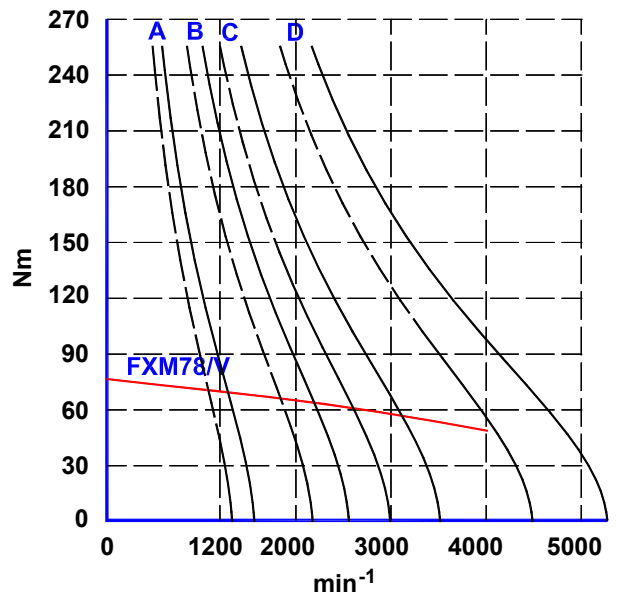
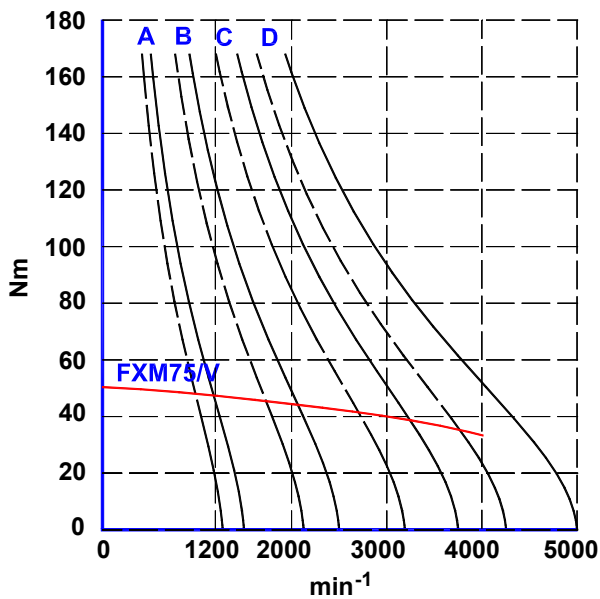
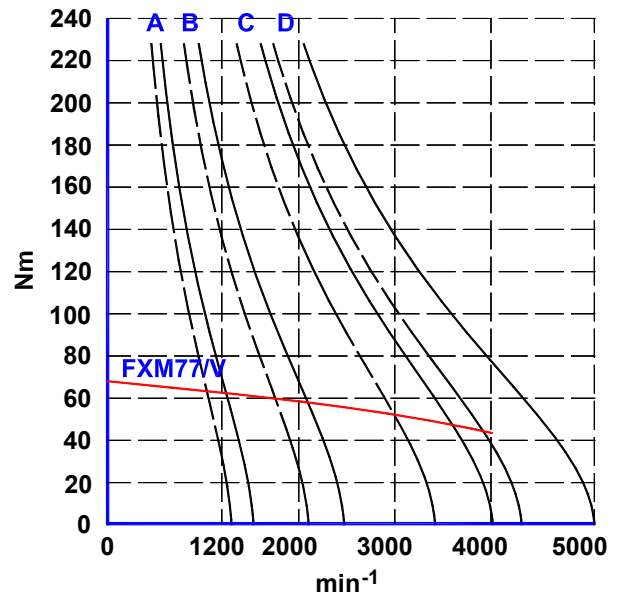
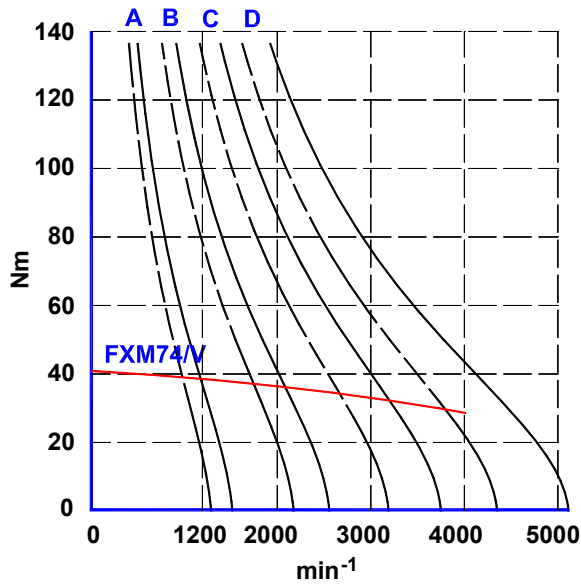
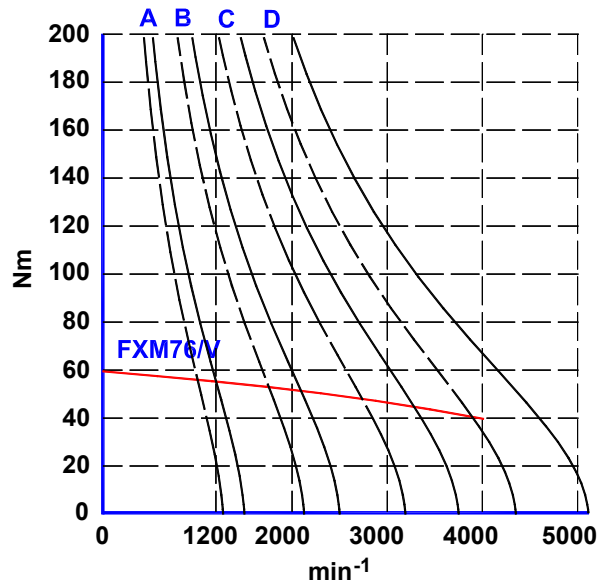
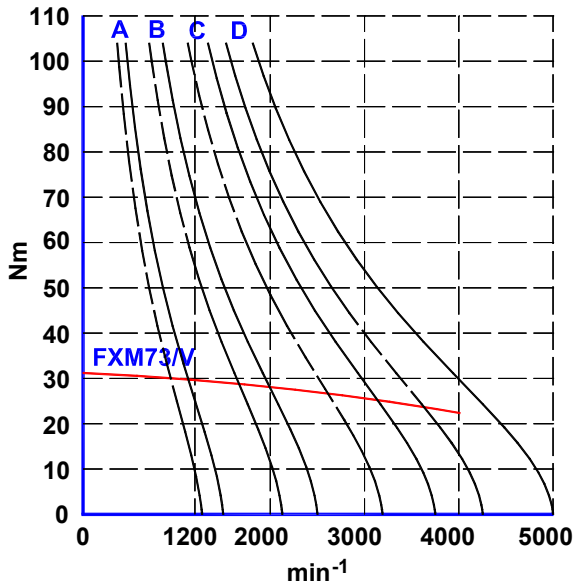

TECHNICAL DATA. VENTILATED FXM MOTORS

VENTILATED MOTORS	Stall torque	Peak torque	Rated speed	Stall current	Peak current	Power	torque constant	acceleration time	Inductance per phase	resistance per phase	Inertia ●●●	mass	Peak torque (Nm) for 0.5 s									
	Mo	Mp	n _N	Io	Imax	Pcal	Kt	tac	L	R	J	P	1.08	1.15	1.25	1.35	2.50	2.75	3.100	3.150		
	N·m	N·m	rpm	Arms	Arms	kW	Nm/Arms	ms	mH	Ω	kgcm ²	kg	N·m	N·m	N·m	N·m	N·m	N·m	N·m	N·m	N·m	
FXM53.12A.□□.□□1	17.8	59	1200	4.2	13.9	2.2	4.2	4.7	61	5.85	22	20										
FXM53.20A.□□.□□1	17.8	59	2000	7.0	23.2	3.7	2.5	7.8	22	2.15	22	20			59.0	-	-	-	-	-	-	-
FXM53.30A.□□.□□1	17.8	59	3000	10.6	35.1	5.6	1.7	11.7	9.6	0.91	22	20				42.5	59.0	-	-	-	-	-
FXM53.40A.□□.□□1	17.8	59	4000	14.0	46.4	7.5	1.3	15.6	5.6	0.55	22	20					45.5	59.0	-	-	-	-
FXM54.12A.□□.□□1	22.2	74	1200	5.3	17.7	2.8	4.2	4.9	44	3.7	29	22			63.0	74.0	-	-	-	-	-	-
FXM54.20A.□□.□□1	22.2	74	2000	8.9	29.7	4.6	2.5	8.2	16	1.35	29	22				62.5	74.0	-	-	-	-	-
FXM54.30A.□□.□□1	22.2	74	3000	13.1	43.7	7.0	1.7	12.3	7.3	0.64	29	22					59.5	74.0	-	-	-	-
FXM54.40A.□□.□□1	22.2	74	4000	17.7	59.0	9.3	1.2	16.4	3.9	0.35	29	22						65.0	74.0	-	-	-
FXM55.12A.□□.□□1	25.9	86	1200	6.1	20.2	3.2	4.2	5.3	36	2.95	36	24.2			63.0	86.0	-	-	-	-	-	-
FXM55.20A.□□.□□1	25.9	86	2000	10.1	33.5	5.4	2.6	8.8	13	1.05	36	24.2				65.0	86.0	-	-	-	-	-
FXM55.30A.□□.□□1	25.9	86	3000	15.4	51.1	8.1	1.7	13.1	5.6	0.45	36	24.2					59.5	85.0	86.0	-	-	-
FXM55.40A.□□.□□1	25.9	86	4000	21.1	70.1	10.8	1.2	17.5	3	0.25	36	24.2						60.0	86.0	-	-	-
FXM73.12A.□□.□□1	31.2	104	1200	7.4	24.7	3.9	4.2	7.4	46	3.05	61	33.2			63.0	104.0	-	-	-	-	-	-
FXM73.20A.□□.□□1	31.2	104	2000	12.3	41.0	6.5	2.5	12.3	17	1.10	61	33.2				62.5	87.5	104.0	-	-	-	-
FXM73.30A.□□.□□1	31.2	104	3000	18.5	61.7	9.8	1.7	18.4	7.4	0.49	61	33.2						85.0	104.0	-	-	-
FXM73.40A.□□.□□1 ●	31.2	104	4000	24.7	82.3	13.1	1.3	24.6	4.2	0.27	61	33.2						65.0	97.5	104.0	-	-
FXM74.12A.□□.□□1	40.9	135	1200	9.8	32.3	5.1	4.2	7.3	33	1.9	79	35.8				105.0	135.0	-	-	-	-	-
FXM74.20A.□□.□□1	40.9	135	2000	16.5	54.5	8.6	2.5	12.2	12	0.68	79	35.8					87.5	125.0	135.0	-	-	-
FXM74.30A.□□.□□1 ●	40.9	135	3000	24.3	80.2	12.8	1.7	18.4	5.4	0.31	79	35.8						85.0	127.5	135.0	-	-
FXM74.40A.□□.□□1 ●	40.9	135	4000	33.1	109.2	17.1	1.2	24.5	2.9	0.17	79	35.8							90.0	120.0	135.0	-
FXM75.12A.□□.□□1	50.4	165	1200	12.0	39.3	6.3	4.2	7.4	27	1.45	97	40.2				105.0	147.0	165.0	-	-	-	-
FXM75.20A.□□.□□1	50.4	165	2000	20.0	65.5	10.5	2.5	12.3	9.7	0.52	97	40.2					125.0	165.0	-	-	-	-
FXM75.30A.□□.□□1 ●	50.4	165	3000	29.9	97.9	15.8	1.7	18.5	4.3	0.23	97	40.2						127.5	165.0	-	-	-
FXM75.40A.□□.□□1 ●	50.4	165	4000	39.9	130.6	21.1	1.3	24.6	2.4	0.13	97	40.2								130.0	165.0	-
FXM76.12A.□□.□□1	59.5	195	1200	14.1	46.2	7.5	4.2	7.4	22	1.1	115	44.2				147.0	195.0	-	-	-	-	-
FXM76.20A.□□.□□1 ●	59.5	195	2000	23.5	77.0	12.5	2.5	12.3	8	0.4	115	44.2					125.0	187.5	195.0	-	-	-
FXM76.30A.□□.□□1 ●	59.5	195	3000	35.3	115.7	18.7	1.7	18.5	3.6	0.18	115	44.2						127.5	170.0	195.0	-	-
FXM76.40A.□□.□□1 ●●	59.5	195	4000	48.2	158.0	24.9	1.2	24.7	1.9	0.1	115	44.2								120.0	180.0	-
FXM77.12A.□□.□□1	68.4	225	1200	16.6	54.6	8.6	4.1	7.4	18	0.87	133	47.2				143.5	205.0	225.0	-	-	-	-
FXM77.20A.□□.□□1 ●	68.4	225	2000	26.8	88.2	14.3	2.5	12.4	7	0.33	133	47.2						195.0	225.0	-	-	-
FXM77.30A.□□.□□1 ●	68.4	225	3000	43.5	143.1	21.5	1.6	18.6	2.6	0.13	133	47.2								160.0	225.0	-
FXM77.40A.□□.□□1 ●●	68.4	225	4000	55.0	180.9	28.6	1.2	24.7	1.7	0.08	133	47.2									180.0	-
FXM78.12A.□□.□□1	76.6	255	1200	19.0	62.2	9.6	4.0	7.4	15	0.71	151	51.2				200.0	255.0	-	-	-	-	-
FXM78.20A.□□.□□1 ●	76.6	255	2000	31.0	103.2	16.0	2.5	12.4	5.7	0.27	151	51.2						187.5	250.0	255.0	-	-
FXM78.30A.□□.□□1 ●	76.6	255	3000	42.6	141.8	24.1	1.8	18.6	3	0.14	151	51.2								180.0	255.0	-
FXM78.40A.□□.□□1 ●●	76.6	255	4000	63.9	212.7	32.1	1.2	24.8	1.3	0.07	151	51.2									180.0	-

- Motors with a power “base” which need to be connected via MC 46 type socket.
- Motors with a power “base” which need to be connected via MC 80 type socket. All the others with MC 23. In bold, the drive recommended for each motor.
- When adding a mechanical brake (optional) to the motor, the moment of inertia values of the brake will also have to be taken into account.

DIMENSIONS

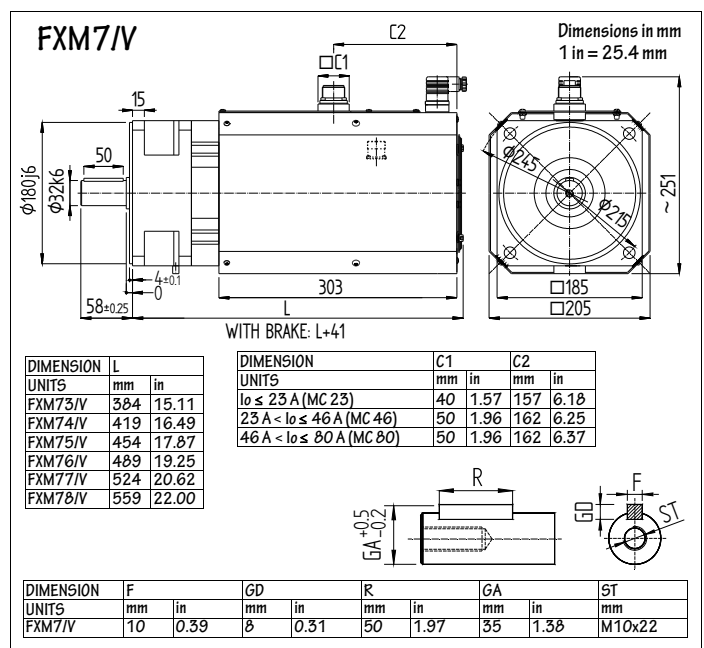
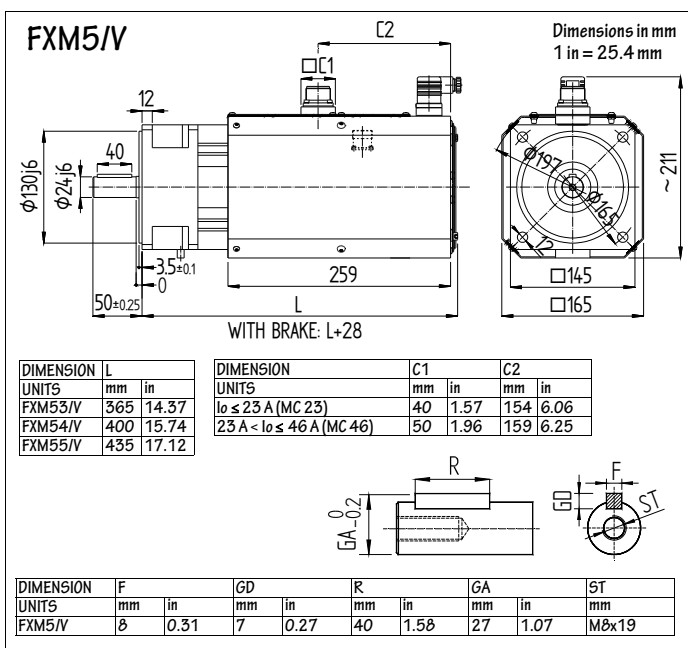
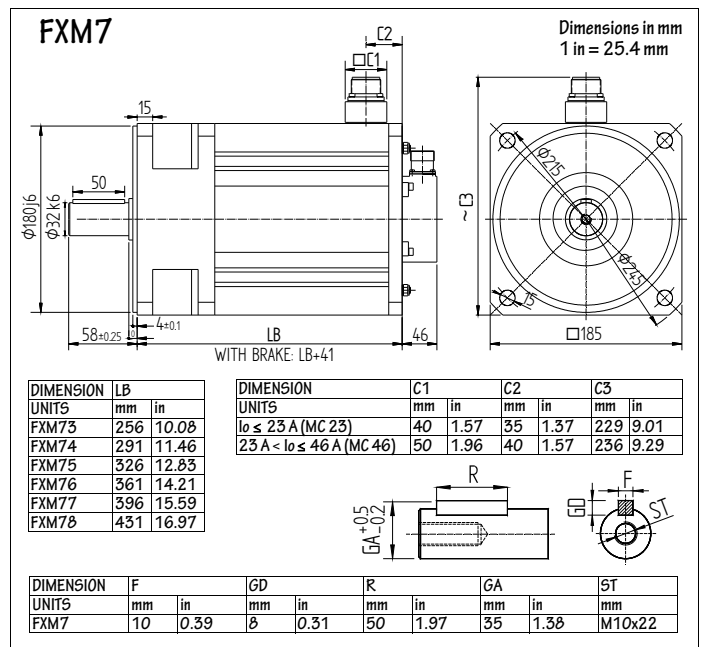
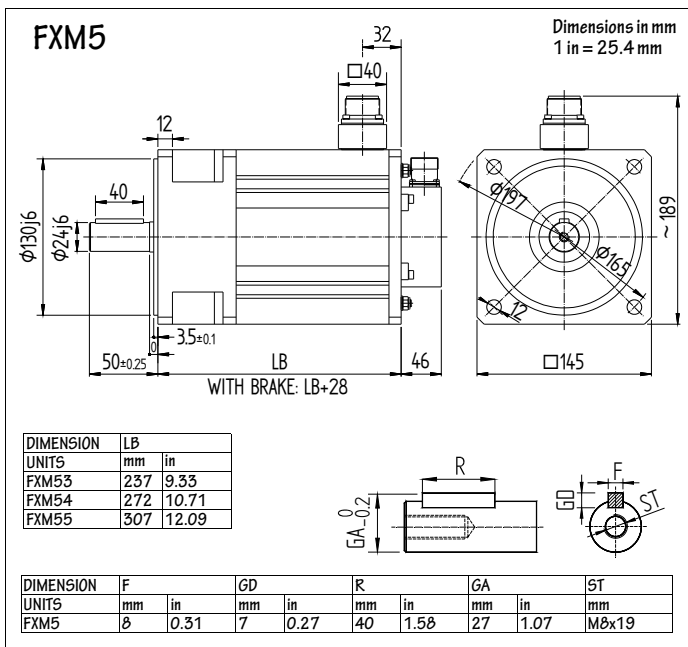
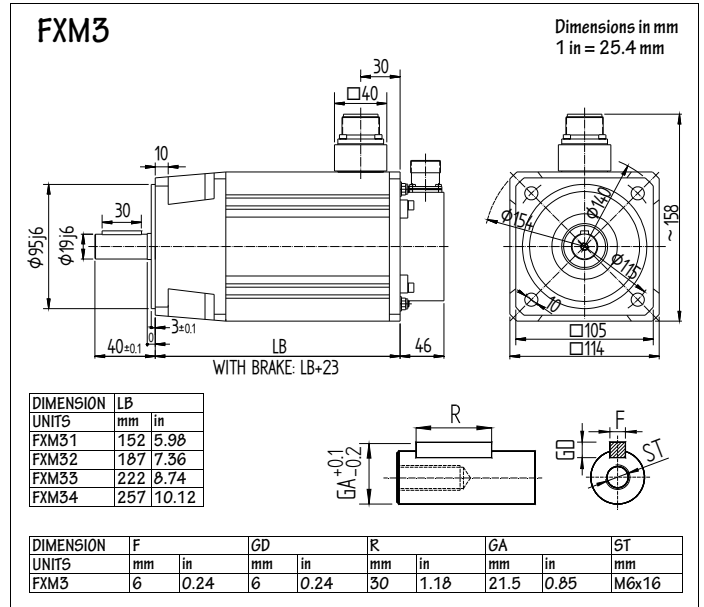
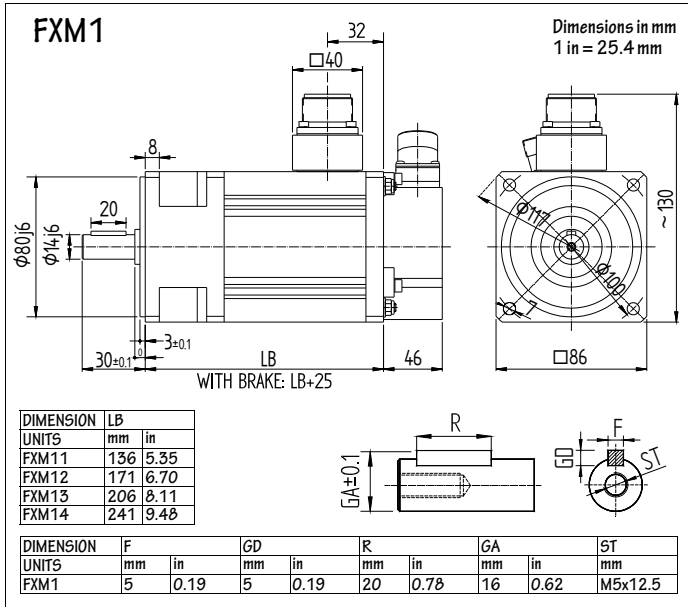

POWER CONNECTORS

MC 23, AMC 23 SEALING: IP 67	
PIN	SIGNAL
A	U PHASE
B	V PHASE
C	W PHASE
D	PE
E	BRAKE [+]
F	BRAKE [-]

MC 46, AMC 46 SEALING: IP 67	
PIN	SIGNAL
A	U PHASE
B	V PHASE
C	W PHASE
D	PE
E	BRAKE [-]
F	BRAKE [-]

MC 80 SEALING: IP 65 STAND	
PIN	SIGNAL
C	U PHASE
H	V PHASE
G	W PHASE
B	PE
A	BRAKE [+]
E	BRAKE [-]

FEEDBACK CONNECTORS

EOC-12 SEALING: IP65 STAND	
PIN	SIGNAL
1	REFCOS
2	+485
3	PTC THERMIST.
4	PTC THERMIST.
5	SIN
6	REFSIN
7	-485
8	COS
9	CHASSIS
10	GND
11	N. C.
12	+ 8 VDC

IOC-17 SEALING: IP65 STAND	
PIN	SIGNAL
1	A+
2	A-
3	+ 5 VDC
4	GND
5	B+
6	B-
7	Z+
8	Z-
9	PTC THERMIST.
10	PTC THERMIST.
11	U+
12	U-
13	V+
14	V-
15	W+
16	W-
17	SHIELD+CHASSIS

BRAKE CHARACTERISTICS

The brake (motor shaft) must never exceed its maximum speed. Voltage over 22-26 V DC will lock the axis.

Motor	Holding torque	Power consumption	Time on/off	Inertia	Mass
Units	N·m (lbf·ft)	W (HP)	ms	kg·cm ²	kg (lbf)
FXM1	Motor Mo	12 (0.016)	19/29	0.38	0.3 (0.66)
FXM3	Motor Mo	16 (0.021)	20/29	1.06	0.6 (1.32)
FXM5	Motor Mo	18 (0.024)	25/50	3.60	1.1 (2.42)
FXM7	Motor Mo	35 (0.047)	53/97	31.80	4.1 (9.03)

Note. The maximum speed is 10000 rev/min, for all of them except for the brake for the FXM7 series that is 8000 rev/min.

FAN CHARACTERISTICS

FXM5 and FXM7 motors have an optional fan whose characteristics are:

Motor	Frequency	Supply voltage	Power	Flow	Noise	Speed
Units	Hz	V	W	m ³ /h	dBA	1/min
FXM5/V	50	230	45	325	48	2800
FXM7/V	50	230	45	325	48	2800
FXM5/V	60	230	39	380	52	3250
FXM7/V	60	230	39	380	52	3250

PIN	SIGNAL
1	230 VAC 45 W
2	0.25 A 50/60 Hz
3	CHASSIS

GENERAL MOUNTING CONDITIONS

Before installing in onto the machine, the anti-rust paint should be removed from the rotor shaft and the flange. It must always be in a dry and clean place. Mounted so it is easily inspected, cleaned and maintained. Free of corrosive atmosphere and/or explosive gasses or liquids. If the motor is going to be continuously exposed to oil splashes, it should be protected with a guard.

CAUTION!



When installing pulleys or gears for transmission, avoid hitting the shaft. Use some tool that is supported in the threaded hole on the shaft to insert the pulley or the gear.

AXIAL AND RADIAL LOADS

A poor alignment between the motor shaft and the machine axis increases vibration of the shaft and reduces the useful life of bearings and couplings. Likewise, exceeding certain maximum radial load values on the bearings has a similar effect.

Follow these considerations in order to avoid these problems:

- ❑ Use flexible couplings for direct coupling.
- ❑ Avoid radial and axial loads on the motor shaft making sure not to exceed the limit values.



MANDATORY. When applying a combined axis and radial load, decrease the maximum radial force allowed $\cdot Fr \cdot$ to 70% of the value indicated in the table.

Series	Axial force $\cdot Fax \cdot$		Radial force $\cdot Fr \cdot$		Distance $\cdot d \cdot$	
	N	lb	N	lb	mm	in
FXM1	105	23.60	500	112.40	15	0.59
FXM3	138	31.02	660	148.37	20	0.78
FXM5	157	35.29	745	167.48	25	0.98
FXM7	336	75.53	1590	357.44	29	1.14

SALES MODEL

The sales model is stored in the motor encoder. The drive software can automatically adjust the motor parameters by reading that "sales model" from the encoder memory.

MOTOR MODEL NOMENCLATURE

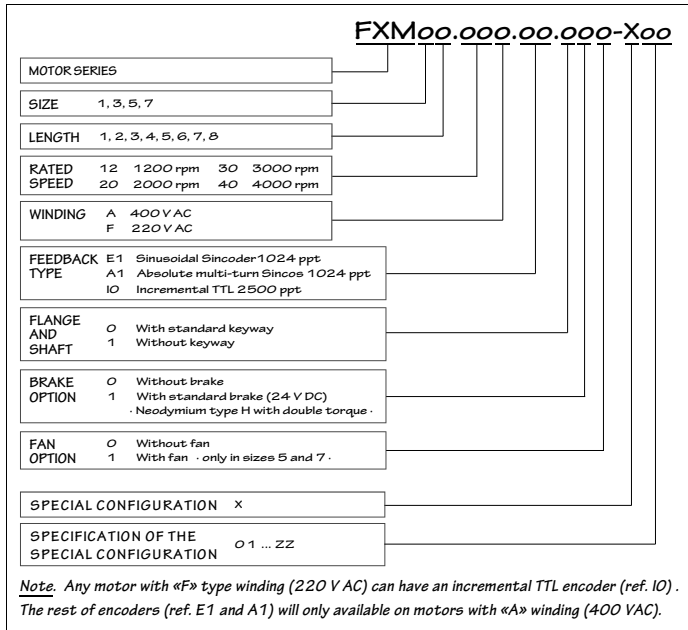

MOUNTING METHODS KEY

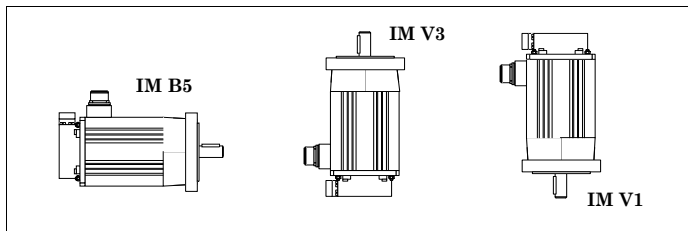

RATING PLATE DATA

The specifications label stuck on FXM servo motors supplied by Fagor Automation S. Coop. offers the necessary data to identify the motor for the user.

8		4		2		3		1	
6		7		15		5		9 13 14	
Mo		7.5 Nm		Io		6 A		Nominal Speed: 4000 rpm	
Mmax		30 Nm		Imax		24 A		B.E.M.F.: 300	
Brake		24 Vdc / 16 W		IP 64		W: 8.5 kg		Bal.d.: N	

1	Serial Nr
2	Version
3	Manufacturing date
4	Stall current
5	Maximum current
6	Stall torque
7	Maximum torque
8	Motor model reference
9	Degree of protection of motor
10	Insulation class
11	Rated speed
12	Level of vibration
13	Weight (mass)
14	BEMF (Back Electro Motor Force)
15	Holding brake (unlocking voltage/power absorbed)

FKM 2/4/6/8 MOTORS

GENERAL CHARACTERISTICS

These motors have been manufactured in accordance with the European regulations EN 60204-1 and EN 60034 as instructed by the European Directive 2006/95/EC on Low Voltage (LVD).

Excitation	Permanent rare earth magnets (Nd-Fe-B)
Temperature sensor	PTC thermistor, KTY-84-130
Shaft extension	Cylindrical without keyway Option: with keyway
Mounting	Face flange with through holes
Mounting methods	IM B5, IM V1, IM V3 meets IEC-34-3-72
Mechanical tolerances	Normal class N, meets IEC-72/1971
Balancing	Class N (class R option) meets DIN 45665 Half-key balancing
Usefull life of bearings	20000 hours
Type of winding **	F winding (220 V AC) A winding (400 V AC)**
Pairs of poles	FKM2, FKM4, FKM6: P=3 FKM8: P=4
Noise emission	DIN 45653
Vibration resistance	Withstands 1g along the shaft and 3g sideways (take $g=9.81 \text{ m/s}^2$)
Stator winding insulation class	Heating class F (150°C/302°F)
Insulation resistance	500 V DC, 10 MΩ or greater
Dielectric rigidity	1500 V AC, 1 minute.
Protection degree	Standard configuration IP 64. Seal option: IP 65.
Storage temperature	-20°C/80°C (-4°F/176°F)
Ambient temperature allowed	0°C/40°C (32°F/104°F)
Working ambient humidity	From 20 % to 80 % (non condensing)
Ventilation ***	Optional only in the FKM8 series. See fan characteristics
Holding brake	Optional on all models
Feedback *	Sinusoidal encoder. Incremental TTL encoder

- * Sinusoidal encoder (FKM with "A" winding) and incremental TTL encoder (FKM with "F" winding).
- ** The FKM8 series only has the "A" winding.
- *** Only the FKM8 series offers the "with fan" option.



WARNING. The F class insulation on the motor keeps its dielectric properties as long as the temperature does not exceed 150°C (302°F) for a cooling temperature of 40°C (104°F).

TEMPERATURE SENSOR

All FKM motors have a KTY84-130 thermistor as thermal protection of the motor and it is located in the stator winding. It has a positive temperature coefficient (PTC) and they should be used in control and measurement systems within a range between -40°C (-40°F) and 300°C (572°F).

Sensor type	KTY-84-130
Resistance at 20°C (68°F)	581 Ω
Resistance at 100°C (212°F)	1000 Ω
Sensor connection	Feedback cable
Response temperature	Break at 145°C ±10°C

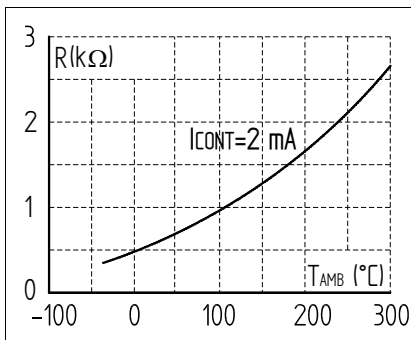

The following figure shows the resistance of the sensor as a function of the ambient temperature (average values).

The wires of the temperature sensor are included in the feedback cable.

The temperature sensor KTY-84-130 has polarity. Therefore, watch its polarity when connecting it!

OUTSIDE APPEARANCE

The following figure shows the location of the connectors for power and motor feedback connection:

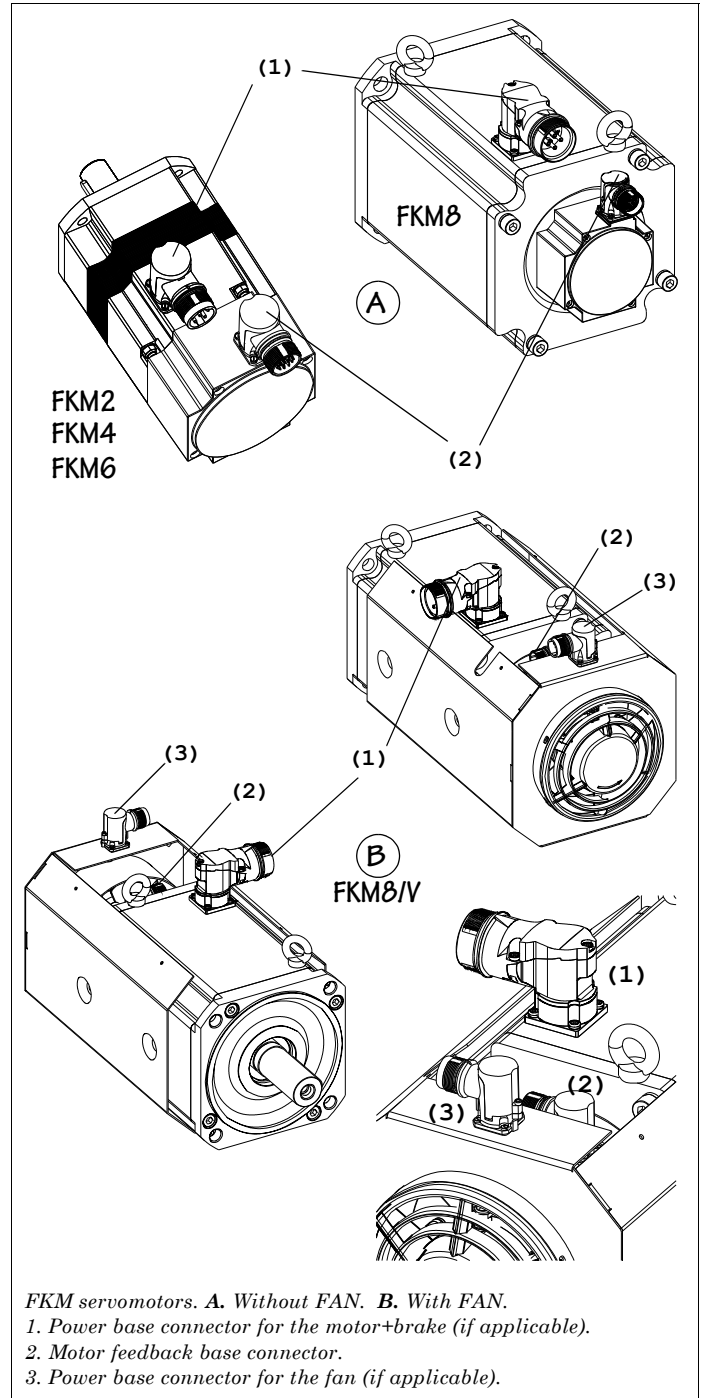

FKM servomotors. A. Without FAN. B. With FAN.

1. Power base connector for the motor+brake (if applicable).
2. Motor feedback base connector.
3. Power base connector for the fan (if applicable).

Rotary connectors

Note that both the power connector and the feedback connector are rotary making it easier to connect the cable when the installation so requires. The possible rotating angles are:

CONNECTOR	MOTOR	Amax	Hmax
POWER (1)	FKM	150°	180°
SIGNAL (2)	FKM2	150°	180°
	FKM4	115°	110°
	FKM6	110°	105°

Note. Certain positions cannot be reached by rotating with the based mounted.

Approx. maximum rotating torque, 8 Nm. Only 5 rotations are allowed in order to keep the degree of protection.

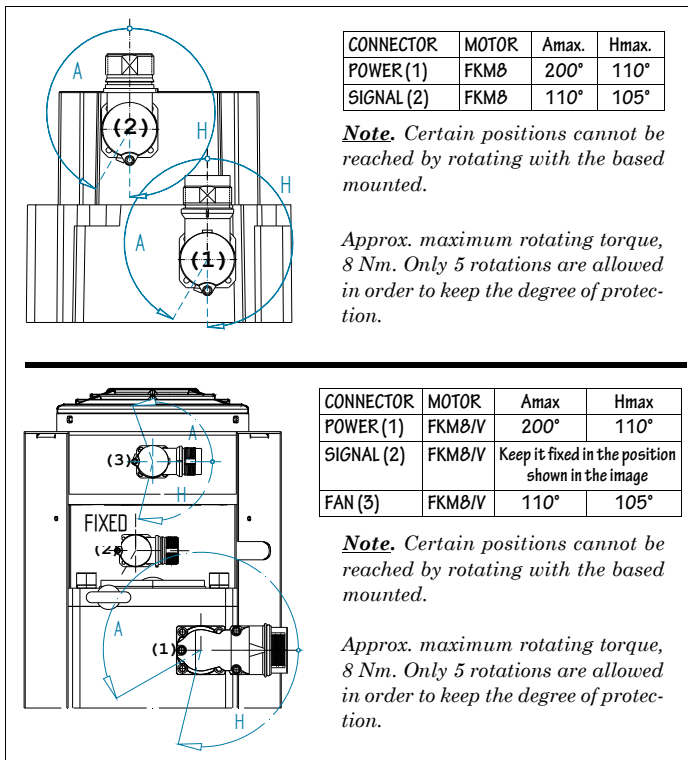

FKM22.50A

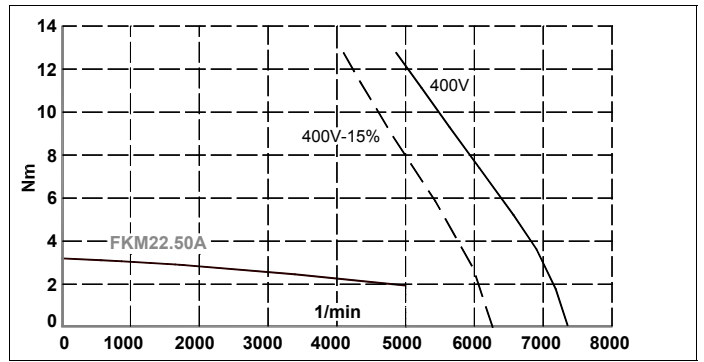

FKM22.60A

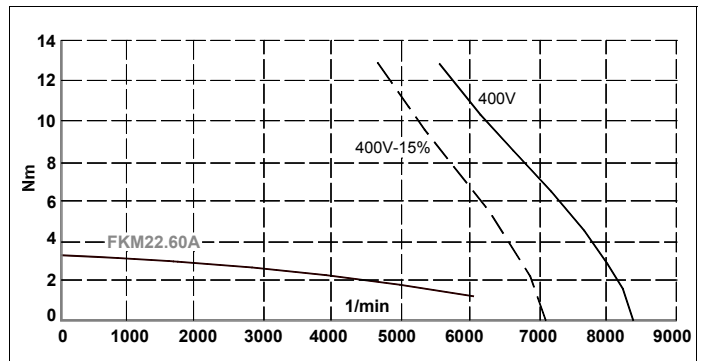

MANDATORY. The indicated rotating angle values must be exceeded. We recommend to rotate both connectors only when necessary and not too often. The more times they are rotated, the torque necessary to rotate them will decrease. They must not be forced permanently.

WARNING. Note that the corresponding cable must be installed on each connector. Remember that each cable has a specific flexibility and, therefore, when handling the connector with the cable installed, its maximum bending radius must not be exceeded.

FKM42.30A

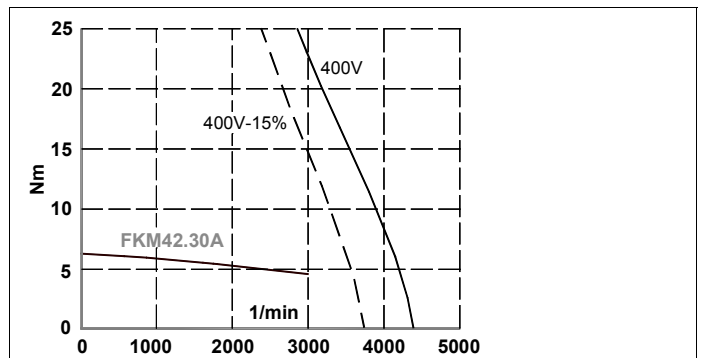

CHARACTERISTICS CURVES. FKM SERIES AT 400 V AC

FKM21.60A

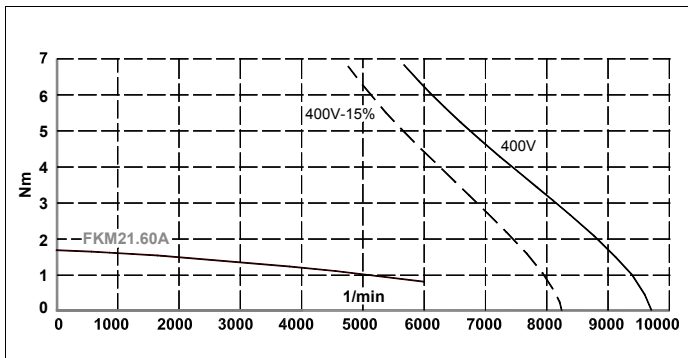

FKM42.45A

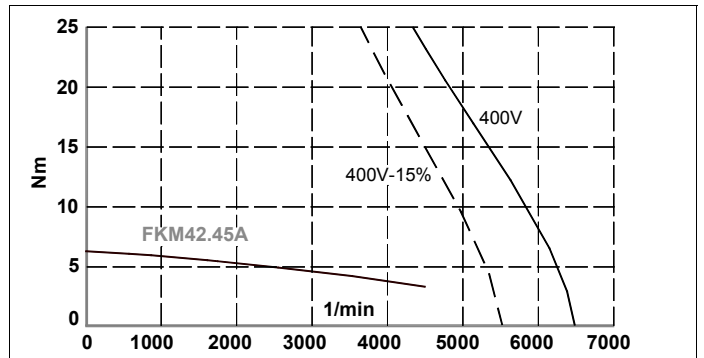

FKM22.30A

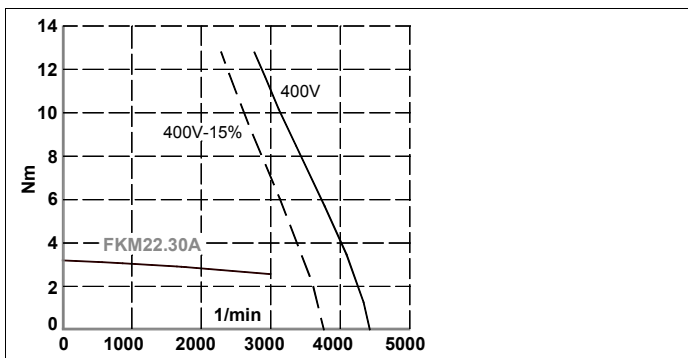

FKM42.60A

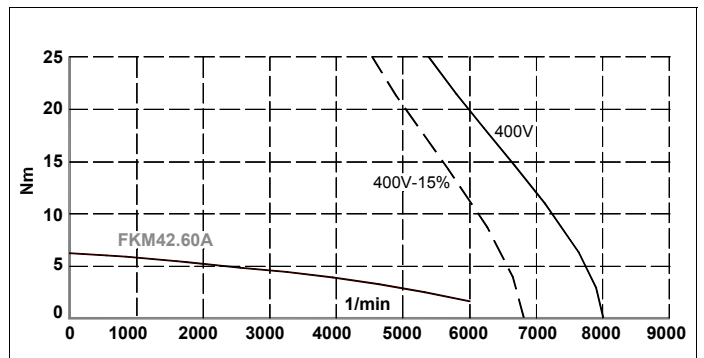

FKM43.20A

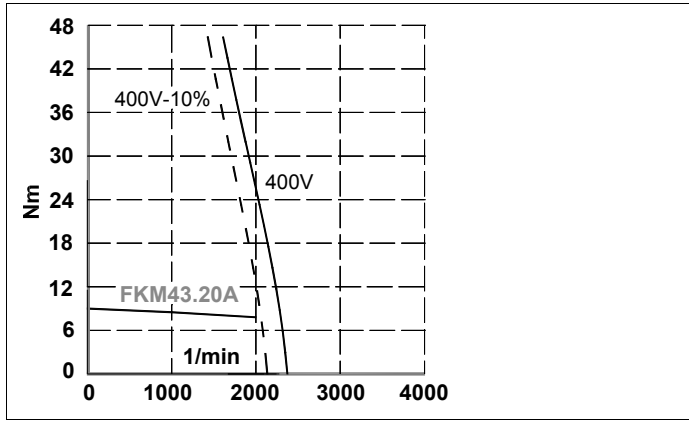

FKM44.30A

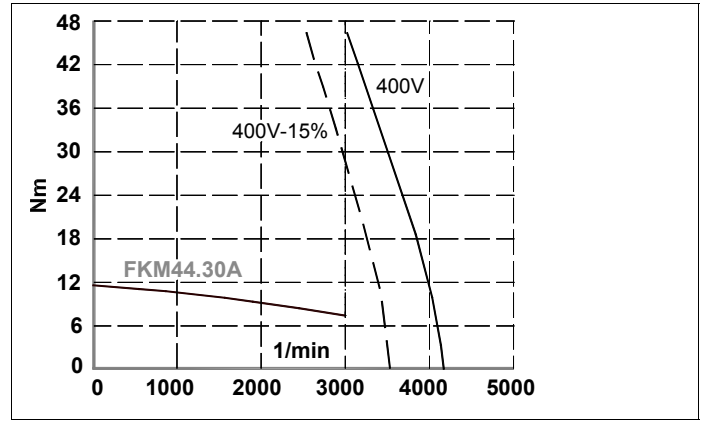

FKM43.30A

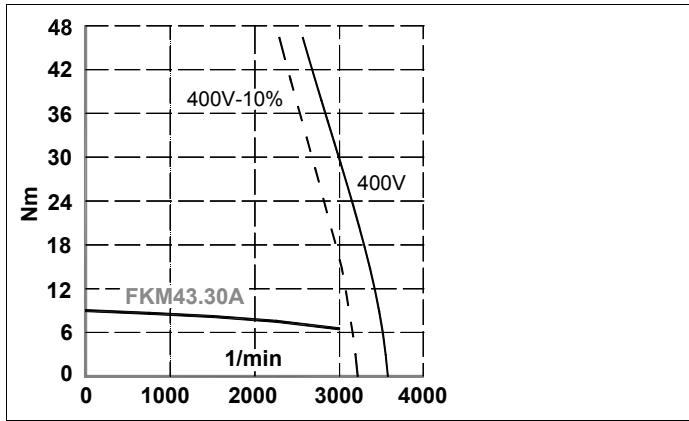

FKM44.30A...-2

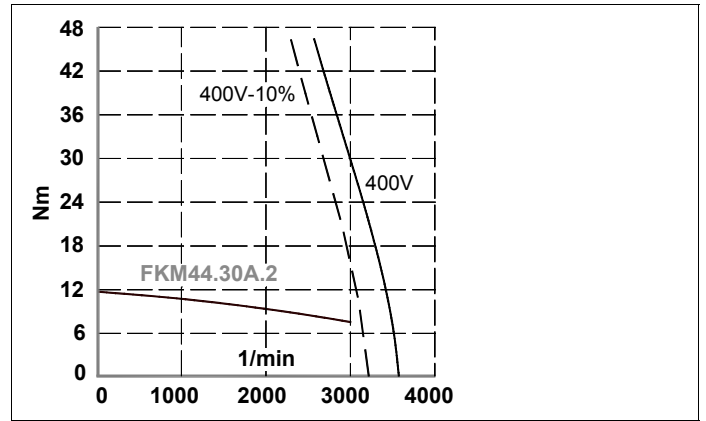

FKM43.40A

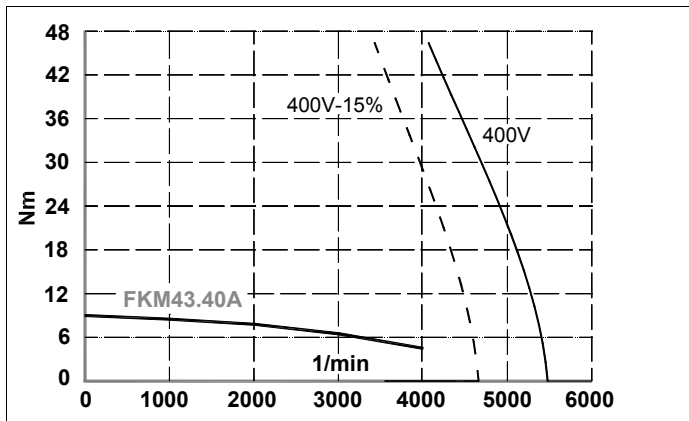

FKM44.40A

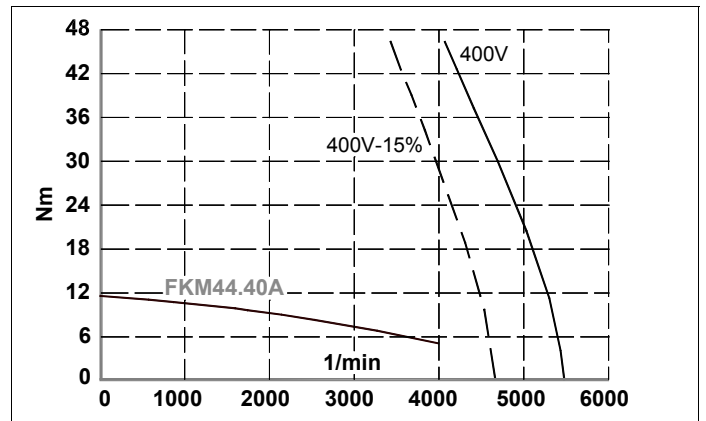

FKM44.20A

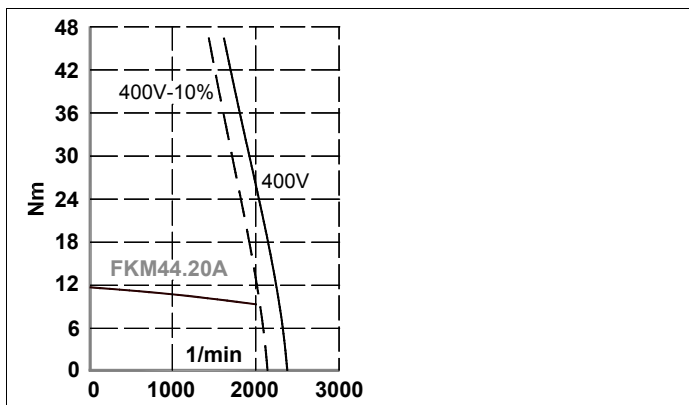

FKM62.30A

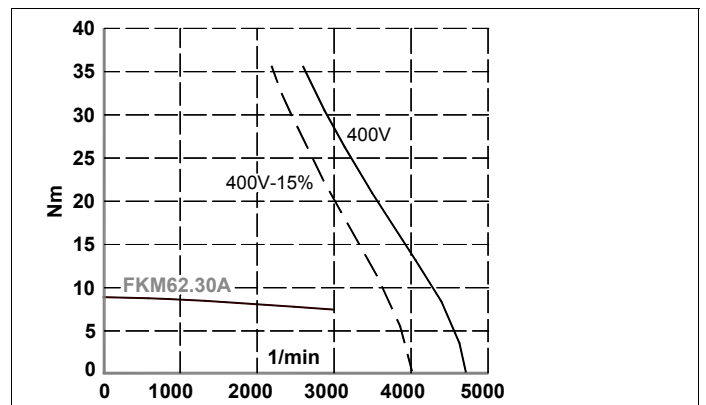

FKM62.40A

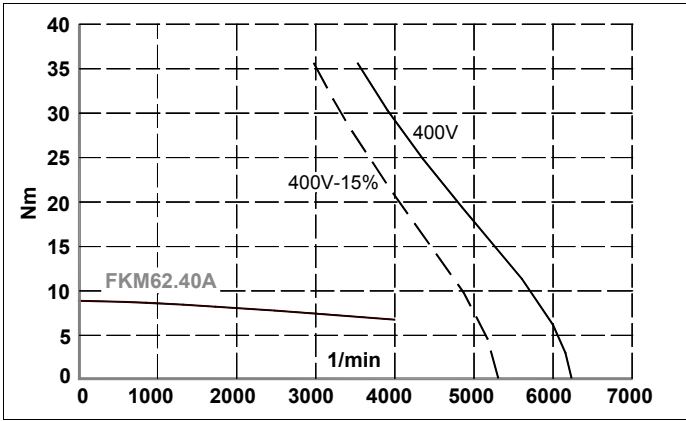

FKM63.40A

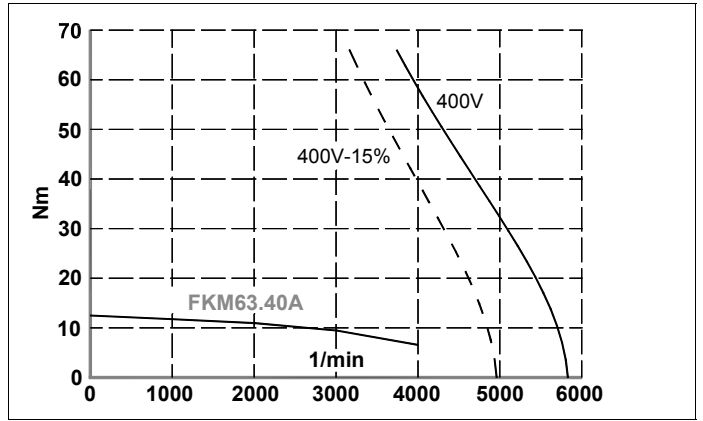

FKM62.60A

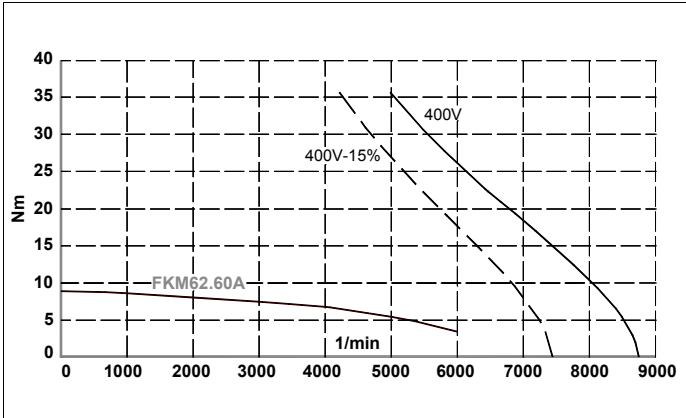

FKM64.20A

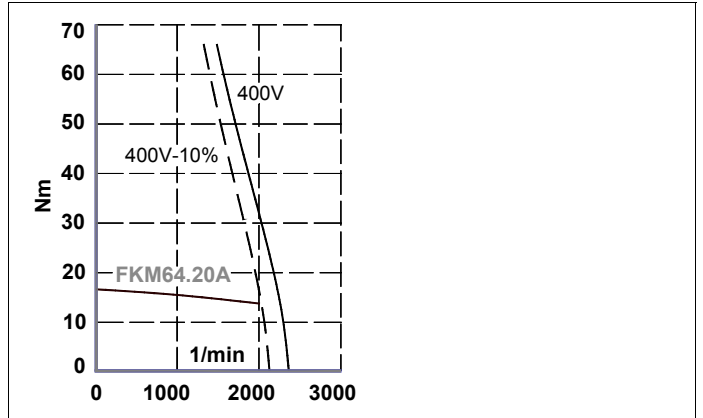

FKM63.20A

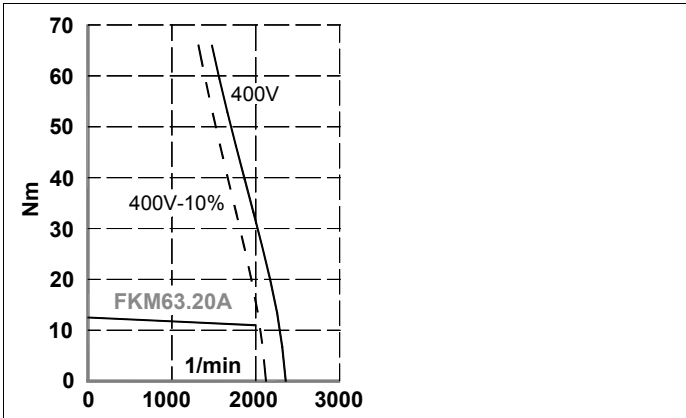

FKM64.30A

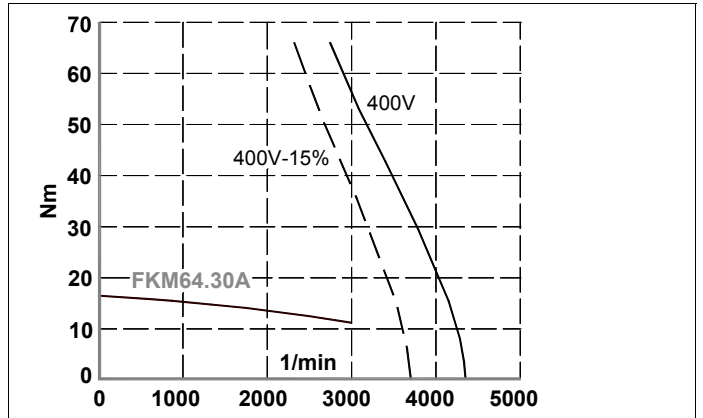

FKM63.30A

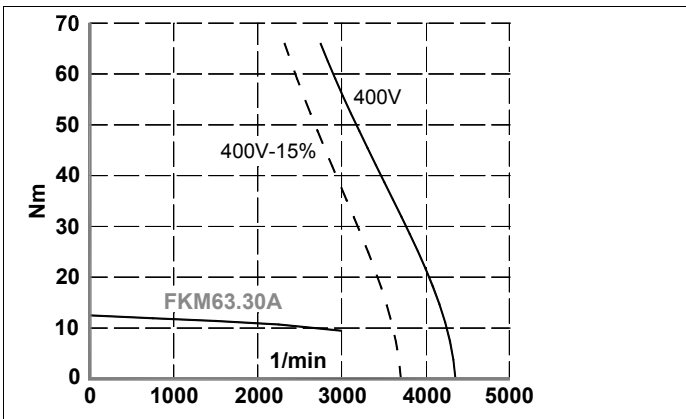

FKM64.40A

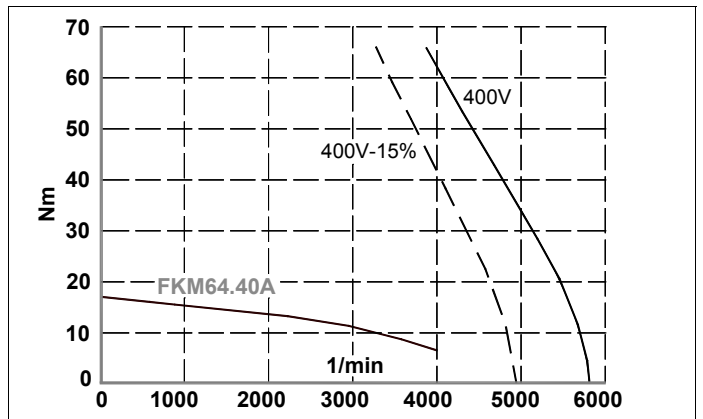

FKM66.20A

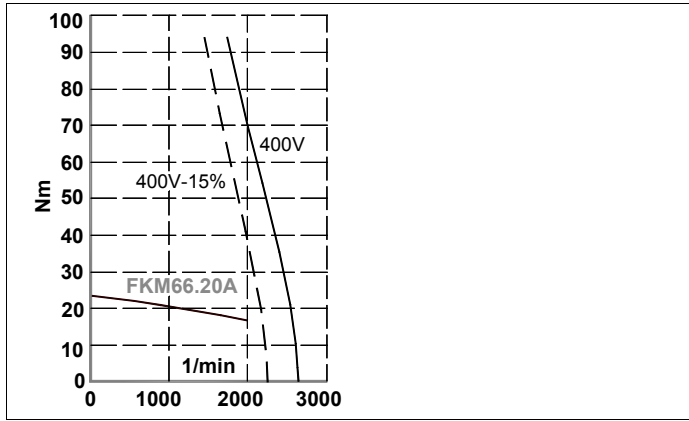

FKM82.30A

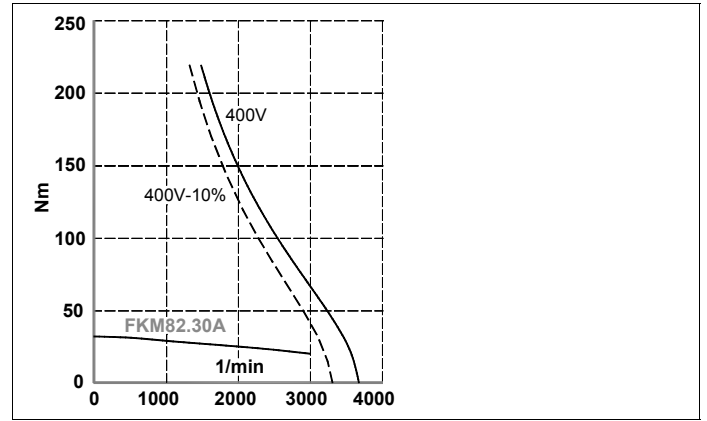

FKM66.20A...-2

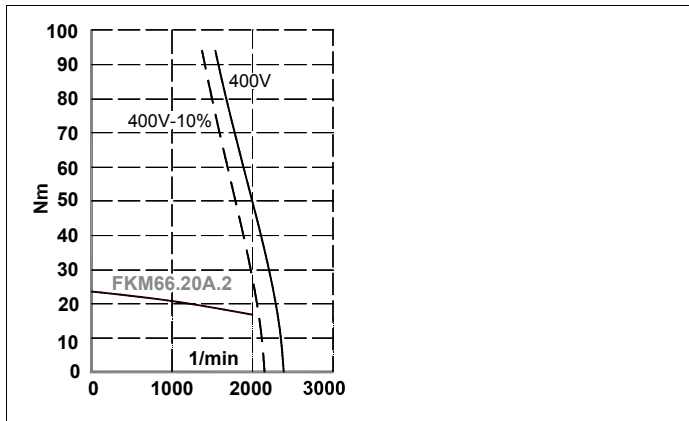

FKM82.40A

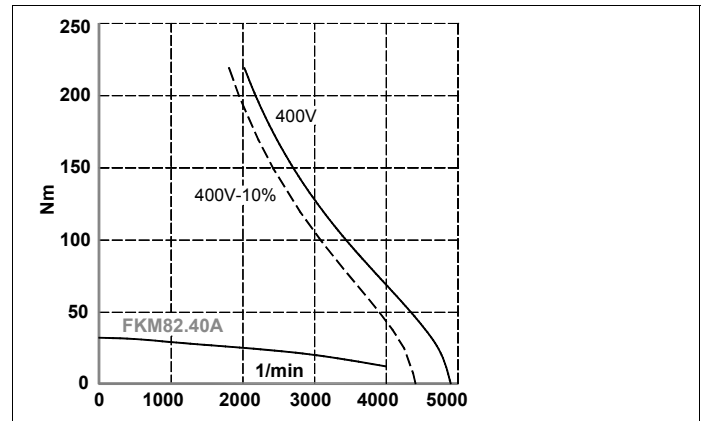

FKM66.30A

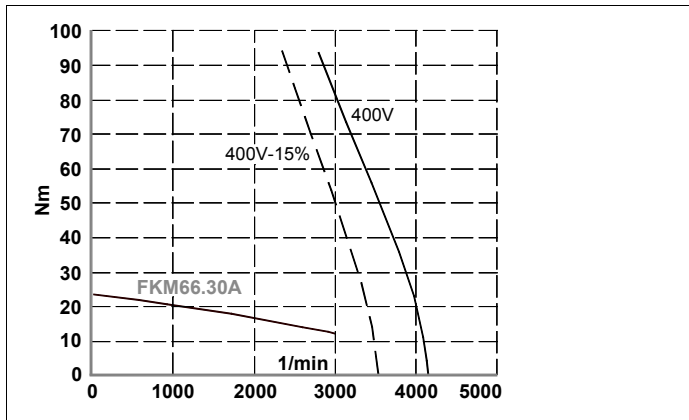

FKM83.20A

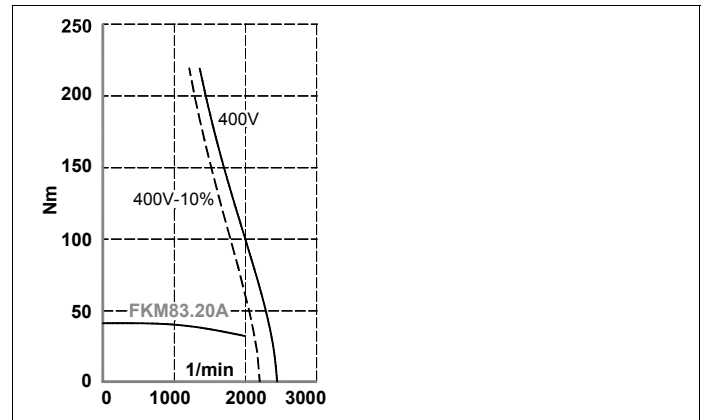

FKM82.20A

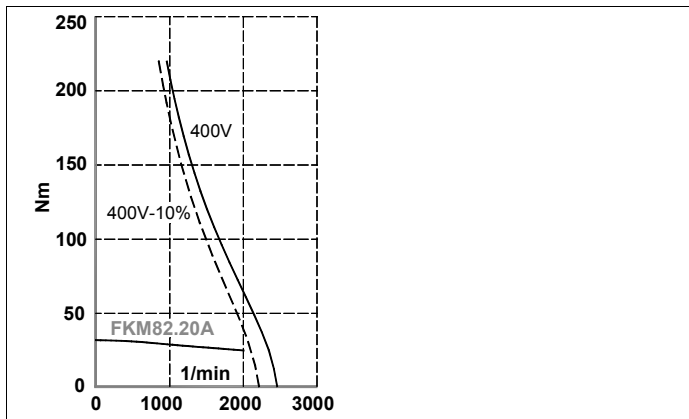

FKM83.30A

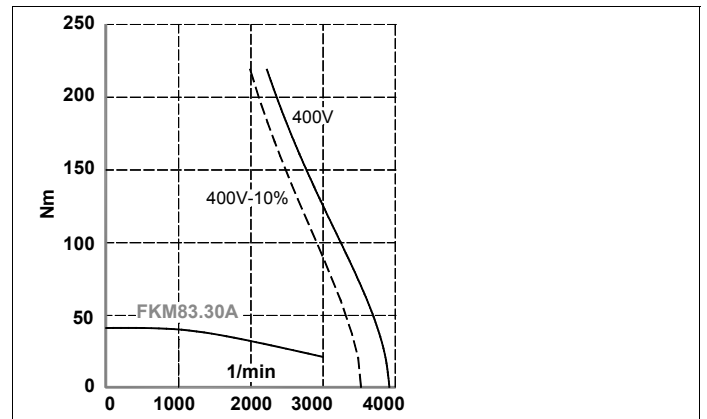

FKM84.20A

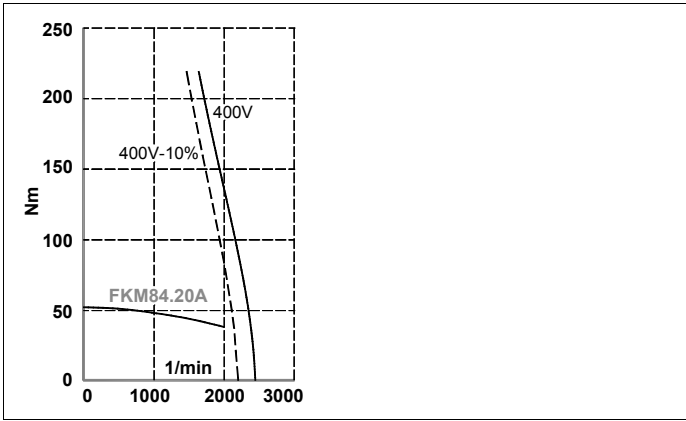

FKM82.30A-V

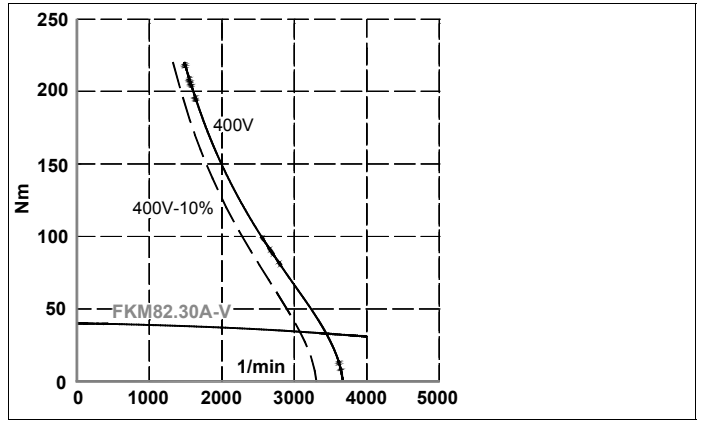

FKM84.30A

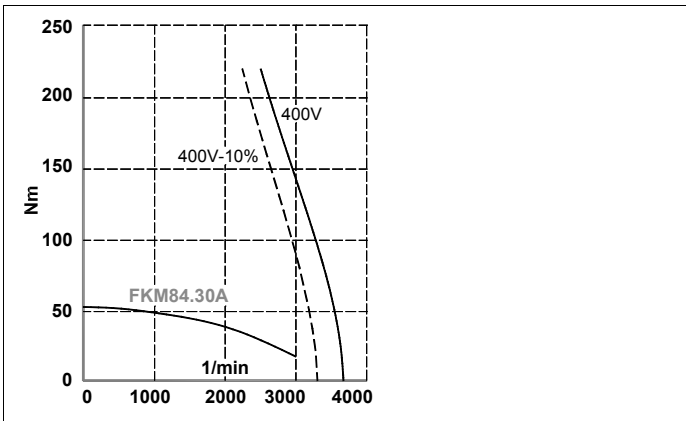

FKM82.40A-V

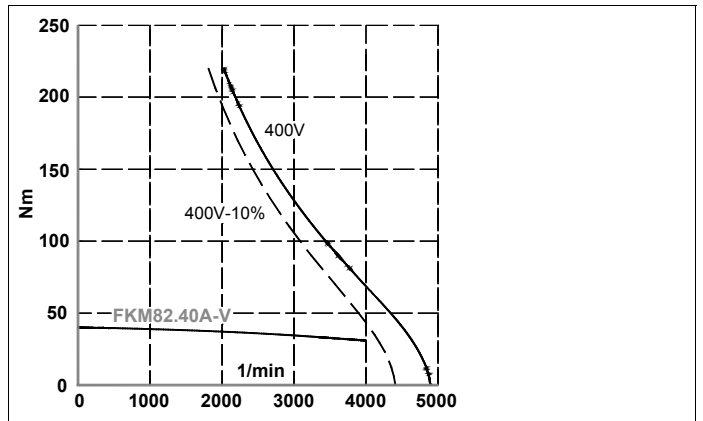

FKM85.20A

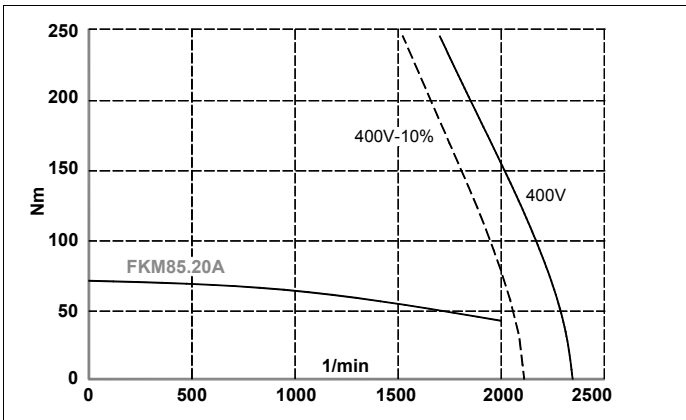

FKM83.20A-V

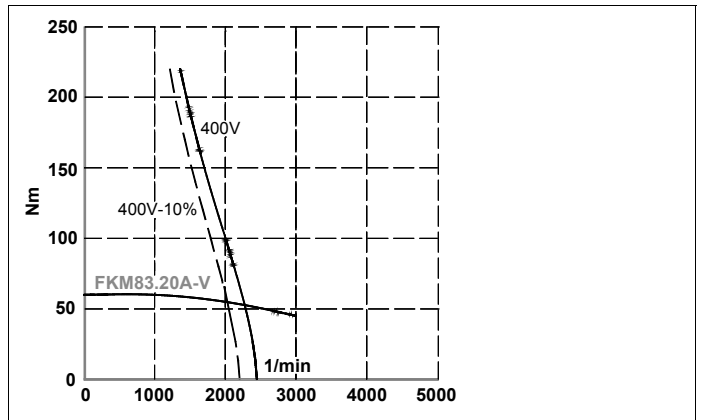

FKM82.20A-V

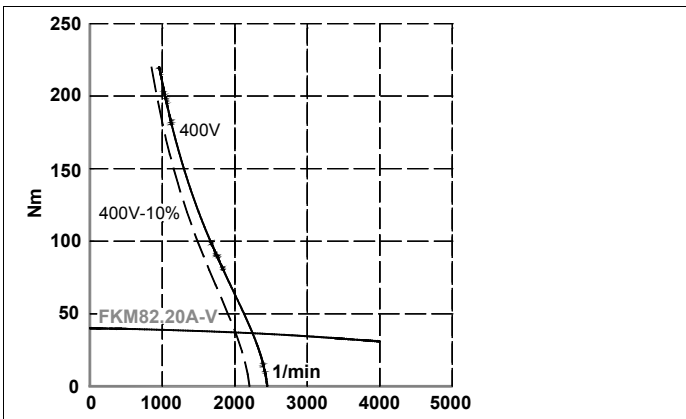

FKM83.30A-V

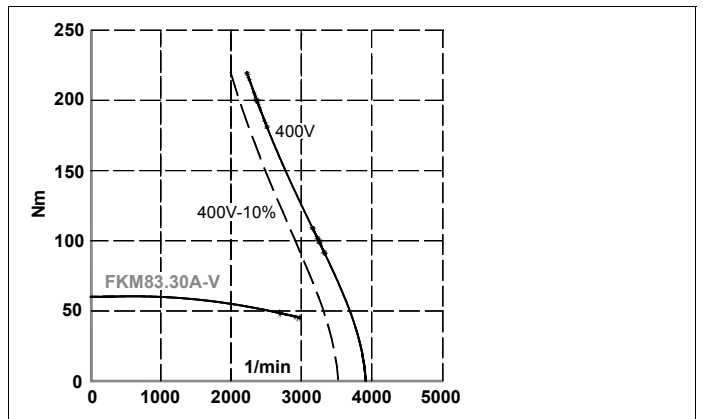

FKM84.20A-V

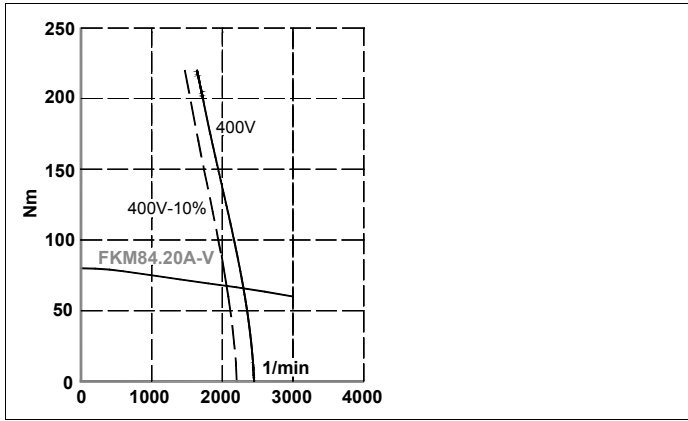

FKM85.20A-V

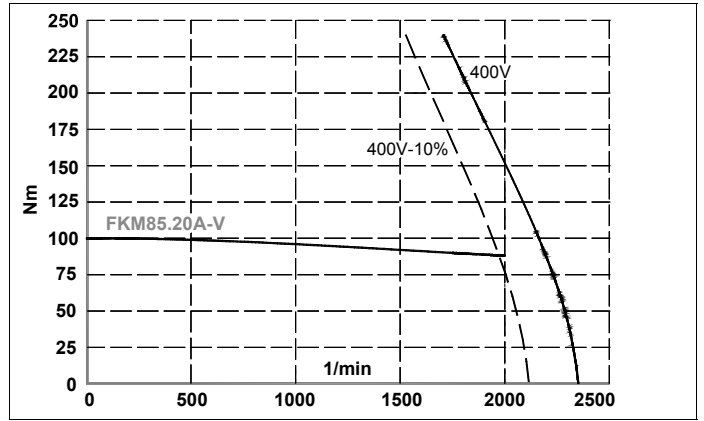

FKM84.30A-V

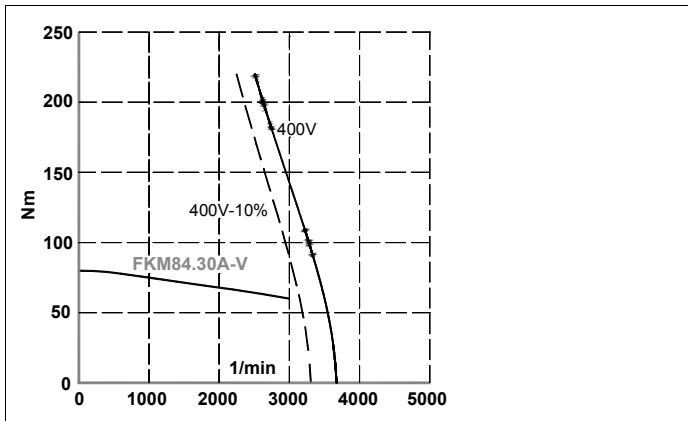

FKM85.30A-V

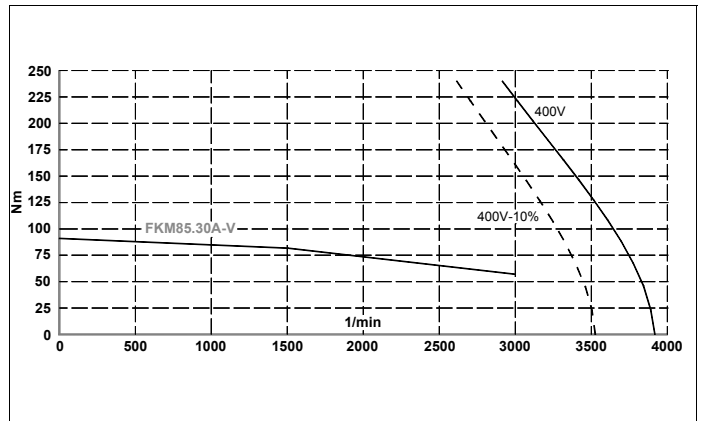

Technical data

MOTORS	Stall torque	Peak torque	Rated speed	Stall current	Peak current	Calculation power	Torque constant	Acceleration time	Inductance per phase	Resistance per phase	Inertia*	Mass**	AXD Peak torque (Nm) for 0.5 seconds							
	Mo	Mp	n _N	Io	I _{max}	P _{cal}	kt	tac	L	R	J	P	1.08	1.15	1.25	1.35	2.50	2.75	3.100	3.150
	N·m	N·m	rpm	Arms	Arms	kW	Nm/A	ms	mH	Ω	kg·cm ²	kg	N·m	N·m	N·m	N·m	N·m	N·m	N·m	N·m
FKM21.60A.□□.□□0	1.7	7	6000	2.8	11	1.1	0.6	14.4	7.7	2.6	1.6	4.2	4.8	7.0	-	-	-	-	-	-
FKM22.30A.□□.□□0	3.2	13	3000	2.4	10	1.0	1.3	7.0	16	3.95	2.9	5.3	10.6	13.0	-	-	-	-	-	-
FKM22.50A.□□.□□0	3.2	13	5000	4.0	16	1.7	0.8	11.7	5.8	1.4	2.9	5.3	6.4	12.0	13.0	-	-	-	-	-
FKM22.60A.□□.□□0	3.2	13	6000	4.5	18	2.0	0.7	14.0	4.6	1.1	2.9	5.3		10.5	13.0	-	-	-	-	-
FKM42.30A.□□.□□0	6.3	25	3000	4.6	19	2.0	1.3	10.7	8.6	1.45	8.5	7.8		20.1	25.0	-	-	-	-	-
FKM42.45A.□□.□□0	6.3	25	4500	6.9	28	3.0	0.9	16.0	3.9	0.675	8.5	7.8		13.5	22.5	25.0	-	-	-	-
FKM42.60A.□□.□□0	6.3	25	6000	8.5	34	3.9	0.7	21.3	2.6	0.45	8.5	7.8			17.5	25.0	-	-	-	-
FKM43.20A.□□.□□0	9.0	36	2000	3.9	15.7	1.88	2.30	9.7	14.5	1.720	16.7	11.7	18.4	34.5	36.0	-	-	-	-	-
FKM43.30A.□□.□□0	9.0	36	3000	6.2	25	2.82	1.45	14.5	6.2	0.755	16.7	11.7		21.7	36.0	-	-	-	-	-
FKM43.40A.□□.□□0	9.0	36	4000	9.4	38	3.77	0.95	19.4	2.4	0.315	16.7	11.7			23.7	33.2	36.0	-	-	-
FKM44.20A.□□.□□0	11.6	47	2000	4.6	19	2.4	2.5	7.4	14.51	1.72	16.7	11.7		37.5	47.0	-	-	-	-	-
FKM44.30A.□□.□□0	11.6	47	3000	8.2	33	3.6	1.4	11.2	4.2	0.54	16.7	11.7			35.0	47.0	-	-	-	-
FKM44.30A.□□.□□0.2	11.6	47	3000	7.0	28	3.6	1.65	11.1	6.16	0.755	16.7	11.7		24.7	41.2	47.0	-	-	-	-
FKM44.40A.□□.□□0	11.6	47	4000	10.7	43	4.9	1.1	14.9	2.4	0.315	16.7	11.7			27.5	38.5	47.0	-	-	-
FKM62.30A.□□.□□0	8.9	35	3000	7.1	28	2.8	1.2	14.3	7.2	0.77	16.0	11.9		18.0	30.0	35.0	-	-	-	-
FKM62.40A.□□.□□0	8.9	35	4000	9.3	37	3.7	0.9	19.1	4.1	0.44	16.0	11.9			22.5	31.5	35.0	-	-	-
FKM62.60A.□□.□□0	8.9	35	6000	13.1	52	5.6	0.6	28.7	2.1	0.225	16.0	11.9				23.8	34.0	35.0	-	-
FKM63.20A.□□.□□0	12.5	51	2000	5.3	21.3	2.6	2.35	12.1	13.2	0.935	29.5	17.1		35.2	51.0	-	-	-	-	-
FKM63.30A.□□.□□0	12.5	51	3000	10.3	40.6	3.9	1.21	18.1	3.8	0.280	29.5	17.1			30.2	42.3	51.0	-	-	-
FKM63.40A.□□.□□0	12.5	51	4000	16.2	64.0	5.2	0.77	24.2	2.1	0.160	29.5	17.1				26.9	38.5	51.0	-	-
FKM64.20A.□□.□□0	16.5	66	2000	6.5	26	3.4	2.53	9.3	13.16	0.935	29.5	17.1		38.0	63.2	66.0	-	-	-	-
FKM64.30A.□□.□□0	16.5	66	3000	12.1	48	5.2	1.4	14.0	3.8	0.285	29.5	17.1			34.0	47.6	66.0	-	-	-
FKM64.40A.□□.□□0	16.5	66	4000	16.2	64	6.9	1.0	18.7	2.1	0.16	29.5	17.1				35.0	50.0	63.0	66.0	-
FKM66.20A.□□.□□0	23.5	94	2000	10.5	42	4.9	2.23	9.5	4.6	0.31	43.0	22.3			55.9	78.0	94.0	-	-	-
FKM66.20A.□□.□□0.2	23.5	94	2000	9.4	37	4.9	2.5	9.57	8.82	0.41	43.0	22.3			62.5	87.5	94.0	-	-	-
FKM66.30A.□□.□□0	23.5	94	3000	16.4	66	7.4	1.4	14.3	2.6	0.17	43.0	22.3				50.1	70.0	94.0	-	-
FKM82.20A.□□.□□0	32.0	96	2000	13.2	39	6.7	2.42	22.4	7.0	0.48	103.0	31.0				84.7	96.0	-	-	-
FKM82.30A.□□.□□0	32.0	96	3000	19.8	59	10.1	1.61	33.6	3.1	0.21	103.0	31.0					80.5	96.0	-	-
FKM82.40A.□□.□□0	32.0	96	4000	26.4	79	13.4	1.21	44.9	1.8	0.12	103.0	31.0						90.9	96.0	-
FKM82.40A.□□.□□1	40.0	96	4000	33.0	79	16.7	1.21	44.9	1.8	0.12	103.0	36.0						90.7	96.0	-
FKM83.20A.□□.□□0	41.0	123	2000	17.0	51	8.6	2.41	25.5	4.6	0.265	150.0	41.0				84.3	120.5	123.0	-	-
FKM83.30A.□□.□□0	41.0	123	3000	27.1	81	12.9	1.51	38.3	1.8	0.100	150.0	41.0						113.4	123.0	-
FKM83.30A.□□.□□1	60.0	123	3000	39.6	81	18.8	1.51	38.3	1.8	0.100	150.0	46.0							123.0	-
FKM84.20A.□□.□□0	52.0	156	2000	21.5	64	10.9	2.41	26.4	3.4	0.18	197.0	50.0					120.5	156.0	-	-
FKM84.20A.□□.□□1	80.0	156	2000	33.0	64	16.7	2.42	26.4	3.4	0.18	197.0	55.0							156.0	-
FKM84.30A.□□.□□0	52.0	156	3000	32.2	96	16.3	1.61	39.6	1.5	0.08	197.0	50.0						121.1	123.0	-
FKM84.30A.□□.□□1	80.0	156	3000	49.5	96	25.1	1.61	39.6	1.5	0.08	197.0	55.0							156.0	-
FKM85.20A.□□.□□0	74.0	222	2000	29.3	87	15.5	2.52	22.91	2.9	0.14	243.0	60.0						189.4	222.0	-
FKM85.20A.□□.□□1	100.0	222	2000	39.6	87	20.9	2.52	22.91	2.9	0.14	243.0	65.0							222.0	-
FKM85.30A.□□.□□1	91.0	222	3000	60.0	145	28.6	1.51	34.37	0.99	0.052	243.0	65.0								222.0

In bold, the drive recommended for each motor.

* When adding a mechanical brake (optional) to the motor, the inertia and mass values of the brake will also have to be taken into account.

DIMENSIONS

FKM2

Dimensions in mm
1 in = 25.4 mm

DIMENSION	LB		L	
UNITS	mm	in	mm	in
FKM21	106	4.17	208	8.19
FKM22	130	5.11	232	9.13

DIMENSION	ØD j6
UNITS	mm in
FKM2	19 0.74

DIMENSION	F		GD		R		GA		ST
UNITS	mm	in	mm	in	mm	in	mm	in	mm
FKM2	6	0.23	6	0.23	30	1.18	21.5	0.84	M6x16

FKM6

Dimensions in mm
1 in = 25.4 mm

DIMENSION	LB		L	
UNITS	mm	in	mm	in
FKM62	136	5.35	260	10.24
FKM63	172	6.77	296	11.65
FKM64	172	6.77	296	11.65
FKM66	208	8.18	332	13.07

DIMENSION	ØD j6
UNITS	mm in
FKM6	32 1.26

DIMENSION	F		GD		R		GA		ST
UNITS	mm	in	mm	in	mm	in	mm	in	mm
FKM6	10	0.39	8	0.31	50	1.96	35	1.37	M10x22

FKM4

Dimensions in mm
1 in = 25.4 mm

DIMENSION	LB		L	
UNITS	mm	in	mm	in
FKM42	133	5.23	247	9.72
FKM43	175	6.88	289	11.38
FKM44	175	6.88	289	11.38

DIMENSION	ØD j6
UNITS	mm in
FKM4	24 0.94

DIMENSION	F		GD		R		GA		ST
UNITS	mm	in	mm	in	mm	in	mm	in	mm
FKM4	8	0.31	7	0.27	40	1.57	27	1.06	M8x19

FKM8

Dimensions in mm
1 in = 25.4 mm

DIMENSION	WITHOUT BRAKE		L		WITH BRAKE		L	
UNITS	mm	in	mm	in	mm	in	mm	in
FKM82	246	9.68	388	15.27	296	11.65	438	17.24
FKM83	296	11.65	438	17.24	346	13.62	488	19.21
FKM84	346	13.62	488	19.21	396	15.59	538	21.18
FKM85	396	15.59	538	21.18	446	17.55	588	23.14

DIMENSION	ØD k6
UNITS	mm in
FKM8	38 1.49

DIMENSION	F		GD		R		GA		ST
UNITS	mm	in	mm	in	mm	in	mm	in	mm
FKM8	10	0.39	8	0.31	70	2.75	41	1.61	M12x30

FKM8/V

Dimensions in mm
1 in = 25.4 mm

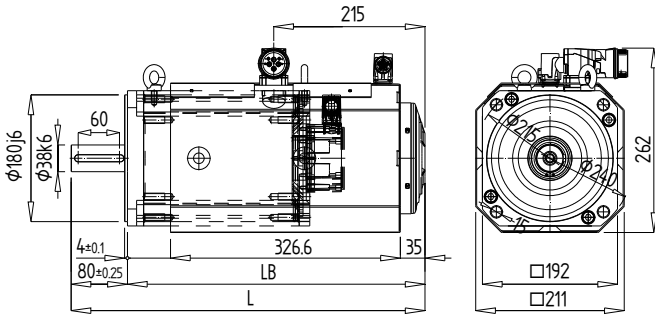

DIMENSION	WITHOUT BRAKE				WITH BRAKE			
	LB		L		LB		L	
UNITS	mm	in	mm	in	mm	in	mm	in
FKM82/V	423	16.65	503	19.80	473	18.62	553	21.77
FKM83/V	473	18.62	553	21.77	523	20.59	603	23.74
FKM84/V	523	20.59	603	23.74	573	22.55	653	25.70
FKM85/V	573	22.55	653	25.70	623	24.52	703	27.67

DIMENSION	ØD k6
UNITS	mm in
FKM8/V	38 1.49

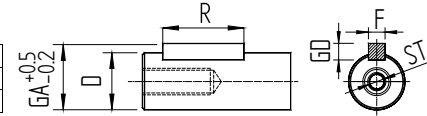

DIMENSION	F	GD	R	GA	ST
UNITS	mm	in	mm	in	mm
FKM8/V	10	0.39	8	0.31	70
					2.75
				41	1.61
					M12x30

HOLDING BRAKE CHARACTERISTICS

The holding brake (motor shaft) must never exceed its maximum speed. Voltage over 22-26 V DC will lock the axis.

Motor	Holding torque	Power consumption	Time on/off	Inertia	Mass
Units	N·m (lbf·ft)	W (hp)	ms	kg·cm ²	kg (lbf)
FKM2	4.5 (3.31)	12 (0.016)	7/35	0.18	0.30 (0.66)
FKM4	9.0 (6.63)	18 (0.024)	7/40	0.54	0.48 (1.06)
FKM6	18.0 (13.27)	24 (0.032)	10/50	1.66	0.87 (1.92)
FKM8 FKM8/V	80.0 (59.00)	35 (0.046)	53/97	31.8	4.10 (9.03)

Note. The max. turning speed of the brake for the FKM2, FKM4 and FKM6 series is 10000 rpm and 8000 rpm for the FKM8 and FKM8/V series.

POWER AND FEEDBACK CONNECTORS

FKM2/4/6

OUTSIDE VIEW OF THE MOTOR POWER CONNECTOR

PIN	SIGNAL
1	U PHASE
2	V PHASE
6	W PHASE
3	PE
4	BRAKE [+]
5	BRAKE [-]

FKM8

OUTSIDE VIEW OF THE MOTOR POWER CONNECTOR

PIN	SIGNAL
U	U PHASE
V	V PHASE
⊖	PE
+	BRAKE [+]
-	BRAKE [-]
W	W PHASE

FKM2/4/6/8

OUTSIDE VIEW OF THE MOTOR FEEDBACK CONNECTOR

PIN	SIGNAL	PIN	SIGNAL
1	REFCOS	7	-485
2	+ 485	8	COS
3	KTY84-	9	CHASSIS
4	KTY84+	10	GND
5	SIN	11	N.C.
6	REFSIN	12	+ 8 VDC

FKM8/V

OUTSIDE VIEW OF THE MOTOR FEEDBACK CONNECTOR

PIN	SIGNAL	PIN	SIGNAL
1	REFCOS	7	-485
2	+ 485	8	COS
3	KTY84-	9	CHASSIS
4	KTY84+	10	GND
5	SIN	11	N.C.
6	REFSIN	12	+ 8 VDC

FKM8

SW: KEY WIDTH

FKM8/V

OUTSIDE VIEW OF THE MOTOR POWER CONNECTOR

PIN	SIGNAL
U	U PHASE
V	V PHASE
⊖	PE
+	BRAKE [+]
-	BRAKE [-]
W	W PHASE

FKM8/V

OUTSIDE VIEW OF THE MOTOR FEEDBACK CONNECTOR

FAN CHARACTERISTICS

The "with fan" option is only available on the FKM8 motor series.

GENERAL MOUNTING CONDITIONS

Before installing in onto the machine, the anti-rust paint should be removed from the rotor shaft and the flange. It must always be in a dry and clean place. Mounted so it is easily inspected, cleaned and maintained. Free of corrosive atmosphere and/or explosive gasses or liquids. If the motor is going to be continuously exposed to oil splashes, it should be protected with a guard.

CAUTION!



When installing pulleys or gears for transmission, avoid hitting the shaft.

Use some tool that is supported in the threaded hole on the shaft to insert the pulley or the gear.

AXIAL AND RADIAL LOADS

A poor alignment between the motor shaft and the machine axis increases vibration of the shaft and reduces the useful life of bearings and couplings. Likewise, exceeding certain maximum radial load values on the bearings has a similar effect.

Follow these considerations in order to avoid these problems:

- ❑ Use flexible couplings for direct coupling.
- ❑ Avoid radial and axial loads on the motor shaft making sure not to exceed the limit values.



MANDATORY. When applying a combined axis and radial load, decrease the maximum radial force allowed $\cdot Fr \cdot$ to 70% of the value indicated in the table.

Series	Axial force $\cdot Fax \cdot$		Radial force $\cdot Fr \cdot$		Distance $\cdot d \cdot$		
	Units	N	lb	N	lb	mm	in
FKM2		125	28.10	668	150.17	20	0.78
FKM4		140	31.47	737	165.68	25	0.98
FKM6		240	53.95	1342	301.69	29	1.14
FKM8		440	98.91	1616	363.29	40	1.57

CAUTION!



Note that the surface of the motor can reach very high temperatures when it is running or it just stopped running. This label warns about this danger.

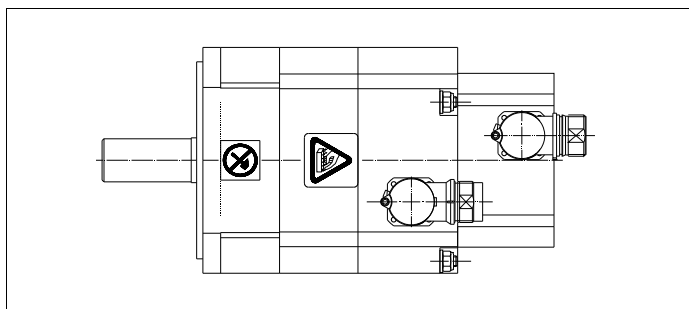

MOUNTING METHODS KEY

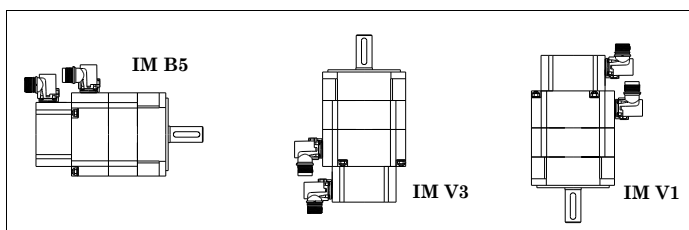

SALES MODEL

The sales model is stored in the motor encoder. The drive software can automatically adjust the motor parameters by reading that "sales model" from the encoder memory.

MOTOR MODEL NOMENCLATURE

FKM00.000.00.000.0-K00	
FAGOR SYNCHRONOUS MOTOR	
SIZE	2, 4, 6, 8
LENGTH	1, 2, 3, 4, 6, 2, 3, 4, 5
RATED SPEED	20 2000 rpm, 45 4500 rpm, 30 3000 rpm, 50 5000 rpm, 40 4000 rpm, 60 6000 rpm
WINDING	A 400 V AC, F 220 V AC
FEEDBACK TYPE	E3 SinCos 1024 ppt, A3 Absolute multi-turn SinCos 1024 ppt, I0 Incremental TTL 2500 ppt
FLANGE AND SHAFT	0 With keyway (half-key balancing), 1 Cylindrical (with no keyway), 2 Shaft with key and seal, 3 Keyless shaft with seal
BRAKE OPTION	0 Without brake, 1 With standard brake (24 V DC)
CONNECTION	0 Rotating angled connectors, 1 With standard fan, 9 Special, 2 Optimized for ACSB-16H
SPECIAL CONFIGURATION	K
SPECIFICATION OF THE SPECIAL CONFIGURATION	01 ... ZZ

Note. Any motor with «F» type winding (220 V AC) can have an incremental TTL encoder (Ref. I0). The rest of encoders (Ref. E3 and A3) will only available on motors with «A» winding (400 V AC).

RATING PLATE DATA

The specifications label stuck on synchronous servomotors supplied by FAGOR offers the necessary data to identify the motor for the user. On series 2, 4, 6 and 8 of the FKM motor family, they correspond with:

8		4		2		3		1	
FAGOR		Fagor Automation S. Coop.(Spain)						CE	
AC BRUSHLESS SERVOMOTOR									
Type XXX XX.XXX.XX.XXX.X				Ver: 00		Date: 03/02		SN.: OF-87789	
Mo 7.5 Nm		Io 6 A		Nominal Speed: 4000 rpm					
Mmax 30 Nm		Imax 24 A		B.E.M.F.: 300		Iso.cl.: F			
Brake 24 Vdc / 16 W		IP 64		W: 8.5 kg		Bal.cl.: N			
15		5		9		13		14	

This characteristics plate of the motor is located on the right side of the motor viewed from its shaft. The items shown on this plate are:

1	Serial Nr
2	Version
3	Manufacturing date
4	Stall current
5	Maximum current
6	Stall torque
7	Maximum torque
8	Motor model reference
9	Degree of protection of motor
10	Insulation class
11	Rated speed
12	Level of vibration
13	Weight (mass)
14	BEMF (Back Electro Motor Force)
15	Holding brake (unlocking voltage/power absorbed)

FKM9 MOTORS

GENERAL CHARACTERISTICS

These motors have been manufactured in accordance with the European regulations EN 60204-1 and EN 60034 as instructed by the European Directive 2006/95/EC on Low Voltage (LVD).

Excitation	Permanent Neodymium magnets
Temperature sensor	PTC thermistor KTY84-130
Shaft end	Cylindrical without keyway Optionally: with keyway
Mounting	Face flange
Mounting methods	IM B5 - IM V1 - IM V3 (as recommended by IEC-34-3-72)
Mechanical tolerances	Normal class N (meets IEC-72/1971)
Balancing	Class N, (class R optional) (DIN 45665)
Type of winding	A winding (400 V AC)
Pairs of poles	P=3
Noise	DIN 45653
Stator winding insulation	Heating class F (150°C/302°F)
Storage temperature	-20°C/80°C (-4°F/176°F)
Ambient temperature	-20°C/40°C (-4°F/104°F)
Working ambient humidity	From 15 % to 85 % (non condensing)
Fan	Not available
Holding brake	Optional only on FKM94 & FKM95 models
Feedback	Sinusoidal encoder



WARNING. The F class insulation of the windings keeps its dielectric properties as long as the temperature stays under 150°C (302°F).

TEMPERATURE SENSOR

KTY-84-130 series sensors have a positive temperature coefficient (PTC) and they should be used in control and measurement systems within a range between -40°C (-40°F) and 300°C (572°F).

Sensor type	KTY-84-130
Resistance at 20 °C (68 °F)	581 Ω
Resistance at 100 °C (212 °F)	1000 Ω
Sensor connection	Feedback cable
Motor series	FKM9

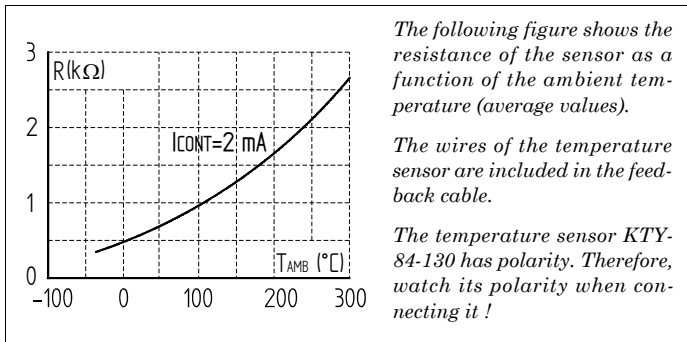

OUTSIDE APPEARANCE

The following figure shows the location of the connectors for power and motor feedback connection:

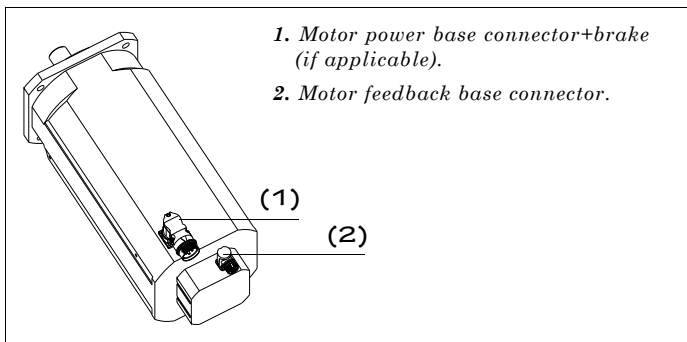

Note that both the power connector and the feedback connector are rotary making it easier to connect the cable when the installation so requires.

Rotary connectors

CONNECTOR	MOTOR	A _{max}	H _{max}
POWER (1)	FKM9	200°	110°
SIGNAL (2)	FKM9	110°	105°

Note. Certain positions cannot be reached by rotating with the based mounted.

Approx. maximum rotating torque, 8 Nm. Only 5 rotations are allowed in order to keep the degree of protection.



MANDATORY. Do not try to exceed the indicated rotating angle values. We recommend to rotate both connectors only when necessary and very seldom. Remember that the more often it is rotated the less torque will be needed to rotate it.



WARNING. Note that the corresponding cable must be installed on each connector. Remember that each cable has a specific flexibility and, therefore, when handling the connector with the cable installed, its maximum bending radius must not be exceeded.

CHARACTERISTICS CURVES. FKM9 SERIES AT 400 V AC

FKM94.20A

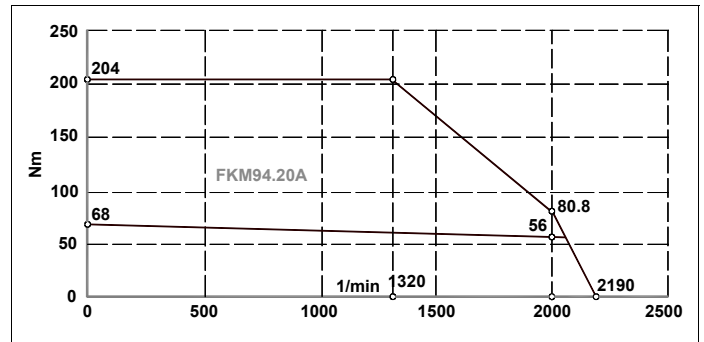

FKM95.20A

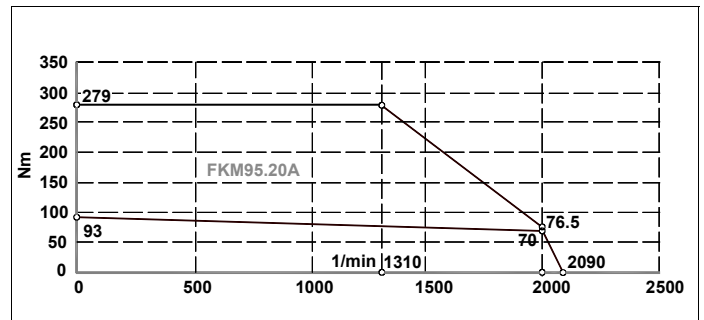

FKM96.20A

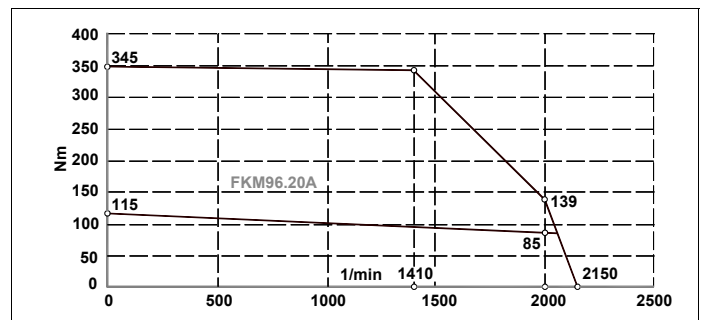

Technical data

MOTORS	Stall torque	Peak torque	Rated speed	Stall current	Peak current	Calculation power	torque constant	acceleration time	inductance per phase	resistance per phase	Inertia*	mass	Peak torque (Nm) for 0.5 seconds		
	Mo	Mp	n _N	Io	Imax	Pow	kt	tac	L	R	J	P	2.75	3.100	3.150
	N·m	N·m	rpm	Arms	Arms	kW	Nm/Arms	ms	mH	Ω	kg·cm ²	kg	N·m	N·m	N·m
FKM94.20A.□□.□□0	68	204	2000	25.4	99	14.2	2.7	11.69	3.15	0.120	430	56	170.1	204	-
FKM95.20A.□□.□□0	93	279	2000	33.1	129	19.5	2.8	11.48	2.40	0.075	550	73	176.4	279	-
FKM96.20A.□□.□□0	115	345	2000	42.1	164	24.0	2.7	11.52	1.70	0.055	660	89		270	334.8

In bold, the drive recommended for each motor.

* When adding a mechanical brake (optional) to the motor, the inertia values of the brake will also have to be taken into account.

DIMENSIONS

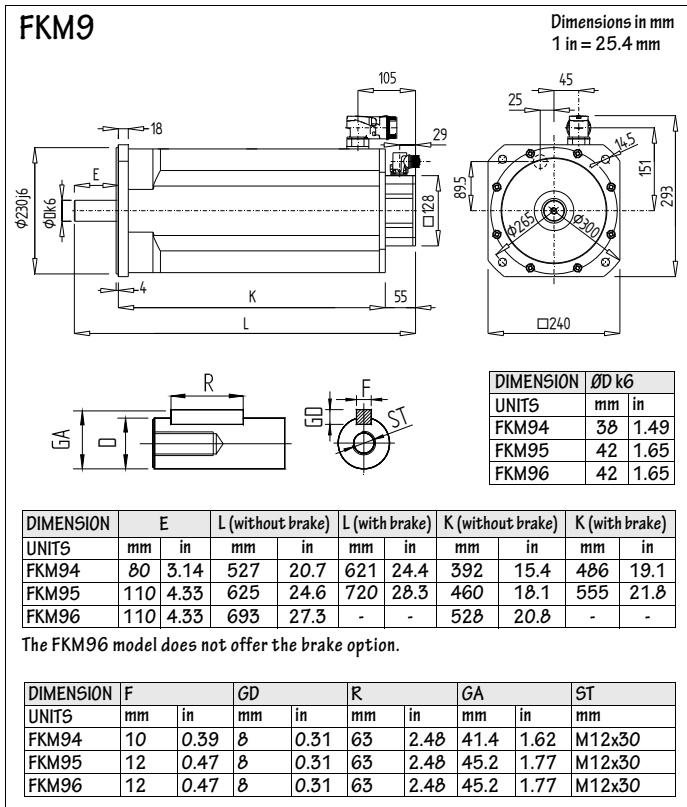

POWER CONNECTOR

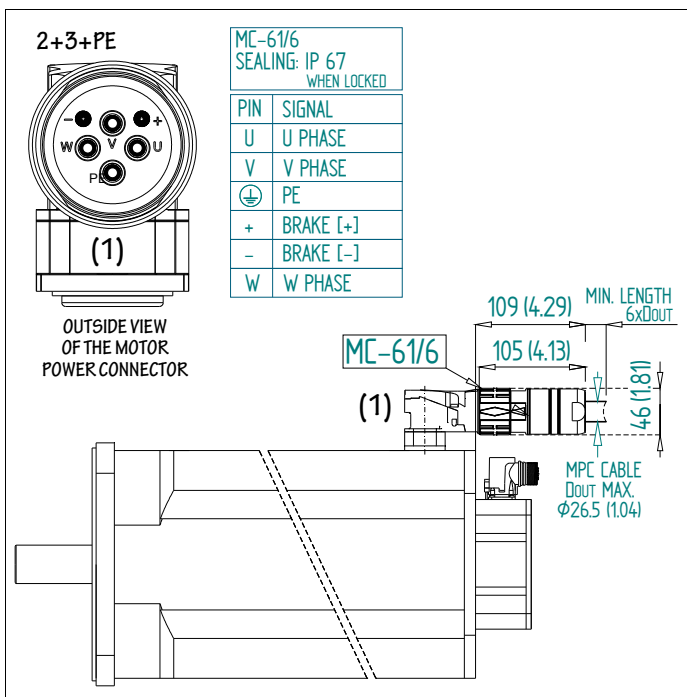

FEEDBACK CONNECTOR

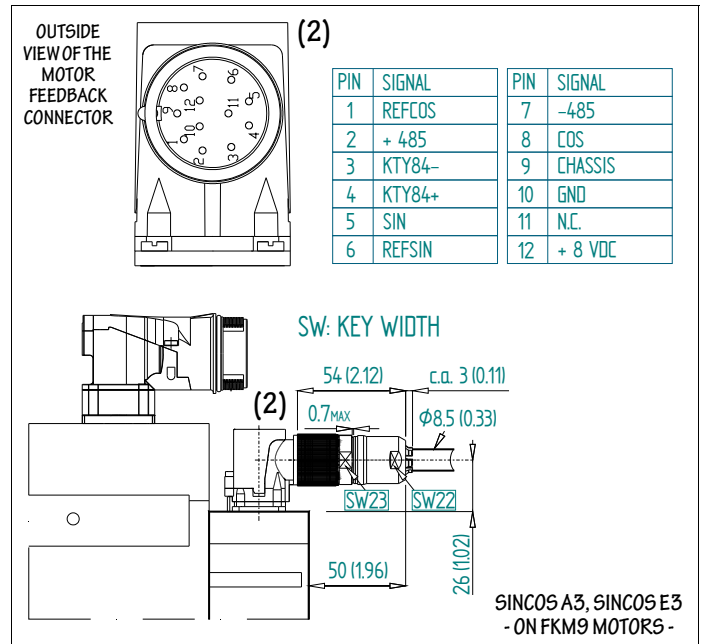

BRAKE CHARACTERISTICS

The brake (motor shaft) must never exceed its maximum speed. Voltage over 26 V will lock the axis.

Motor	Holding torque	Power consumption	Time on/off	Releasing voltage	Inertia	Mass
Units	N·m (lbf·ft)	W (hp)	ms	V DC	kg·cm ²	kg (lbf)
FKM9	145.0 (106.9)	50 (0.067)	65/190	22-26	0.53	5.35 (11.79)

The FKM96 model does not offer the brake option.

FAN CHARACTERISTICS

FKM9 motors do not offer the fan in any of their models.

GENERAL MOUNTING CONDITIONS

Before installing in onto the machine, the anti-rust paint should be removed from the rotor shaft and the flange. It must always be in a dry and clean place. Mounted so it is easily inspected, cleaned and maintained. Free of corrosive atmosphere and/or explosive gasses or liquids. If the motor is going to be continuously exposed to oil splashes, it should be protected with a guard.

CAUTION!



When installing pulleys or gears for transmission, avoid hitting the shaft. Use some tool that is supported in the threaded hole on the shaft to insert the pulley or the gear.

AXIAL AND RADIAL LOADS

A poor alignment between the motor shaft and the machine axis increases vibration of the shaft and reduces the useful life of bearings and couplings.

Likewise, exceeding certain maximum radial load values on the bearings has a similar effect.

Follow these considerations in order to avoid these problems:

- Use flexible couplings for direct coupling.
- Avoid radial and axial loads on the motor shaft making sure not to exceed the limit values.



MANDATORY. When applying a combined axis and radial load, decrease the maximum radial force allowed $\cdot Fr \cdot$ to 70% of the value indicated in the table.

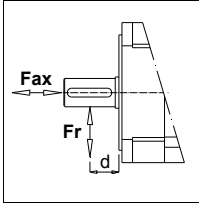

Series	Axial force $\cdot Fax \cdot$		Radial force $\cdot Fr \cdot$		Distance $\cdot d \cdot$	
	N	lb	N	lb	mm	in
FKM9	339	76.21	1775	399.03	E/2*	E/50.8*

* E, length in mm of the shaft end on FKM9 servomotors. See dimension according to model in the dimensions drawing.

MOUNTING METHODS KEY

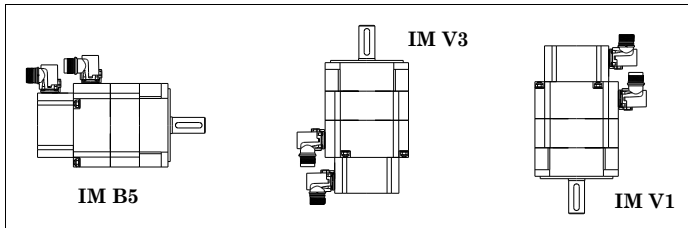

SALES MODEL

The sales model is stored in the motor encoder. The drive software can automatically adjust the motor parameters by reading that "sales model" from the encoder memory.

MOTOR MODEL NOMENCLATURE

FKM00.000.00.000	
FAGOR SYNCHRONOUS MOTOR	
SIZE	9
LENGTH	4, 5, 6
RATED SPEED	20 2000 rpm
WINDING	A 400 V AC
FEEDBACK TYPE	E3 SinCos 1024 ppt A3 Absolute multi-turn SinCos 1024 ppt
FLANGE AND SHAFT	2 With keyway (standard) / IP 65 3 Cylindrical (with no keyway) / IP 65
BRAKE OPTION	0 Without brake 1 With brake
FAN OPTION	0 Without fan

Note. The «FKM96» model does not offer the brake option.

RATING PLATE DATA

The specifications label stuck on FKM9 servo motors supplied by Fagor Automation S. Coop. offers the necessary data to identify the motor for the user.

FAGOR		2	3	7 7 5 5 6 0	CE
6	Typ	FKM96.20A.E3.210			42/08
1	SN	775560	Art.Nr.		
4	M_b	115Nm	U_{dc}	560V	Iso.-Kl. F
5	N_n	2000r/min	I_n	32.36A	IP65
Made in EU					
9					

1	Serial Nr
2	Item number
3	DC voltage of the intermediate circuit
4	Stall torque
5	Rated speed
6	Motor model reference. Motor name.
7	Degree of protection of the motor
8	Insulation class
9	Rated current

ASYNCHRONOUS MOTORS

OPERATING MODES

Next, the motor operating modes are described showing the different zones in the diagram below (power-torque/speed). The motor behavior characteristics are different in each of them. For spindle motors it is crucial to have an ample constant power zone. Three operating zones are established in order to analyze this characteristic. The following graph shows each zone and the motor operating mode in each of them.

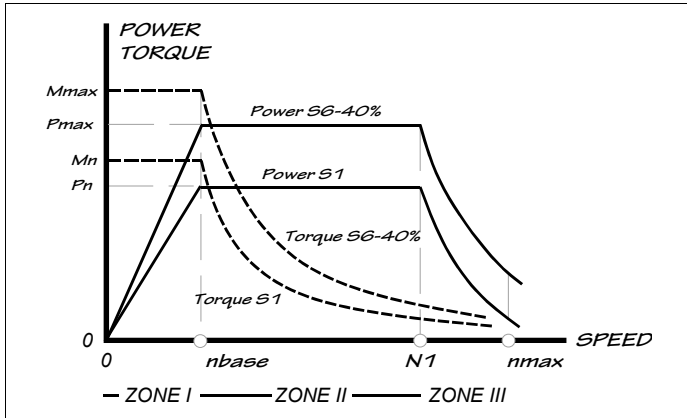

OPERATING ZONES

ZONE I. This zone is established from the rest state - null speed (0 rev/min) - to the nominal operation (rated or base speed). The torque developed by the motor coincides with the rated torque (M_{rated}) and is constant in the whole zone. Its value is obtained as the product of the power generated by the motor (directly proportional to the current circulating through its rotor up to the rated operation point) times its corresponding turning speed. The power developed by the motor is directly proportional to the speed up to the rated operation point where it reaches the rated power (P_{rated}).

ZONE II. This zone is defined as the constant power zone and covers from the nominal operating point to where the motor reaches its maximum available voltage. The torque decreases proportional as the speed increases. The power remains constant.

ZONE III. This zone begins when the voltage at the motor terminals has reached the maximum voltage that the drive can provide. The torque decreases with the square of the speed. The power decreases as the speed increases.

INFLUENCE OF THE SUPPLY VOLTAGE

The supply voltage of the bus sets the electrical limitation on how the motor will run.

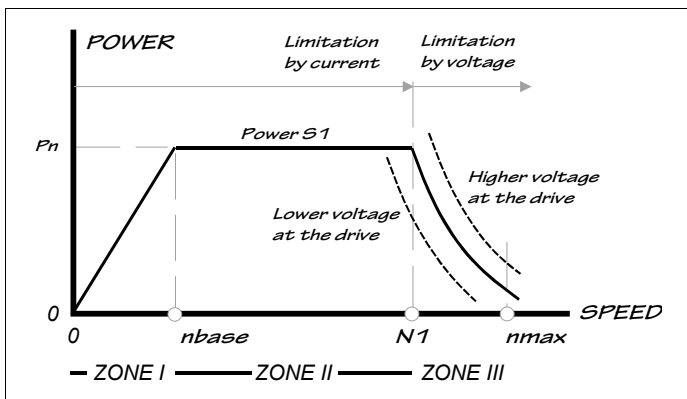

DEFINITIONS

n_{max}. Maximum turning speed allowed. The maximum speed n_{max} depends on the mechanical design (roller bearings life, short-circuit ring of the squirrel cage) and electrical design (voltage limiting characteristics).

n1. Maximum permanent speed. It is the maximum speed allowed permanently (regardless of the speed duty cycle).

S1. S1 duty cycle (continuous). Operation with constant load enough to stabilize the temperature of the motor.

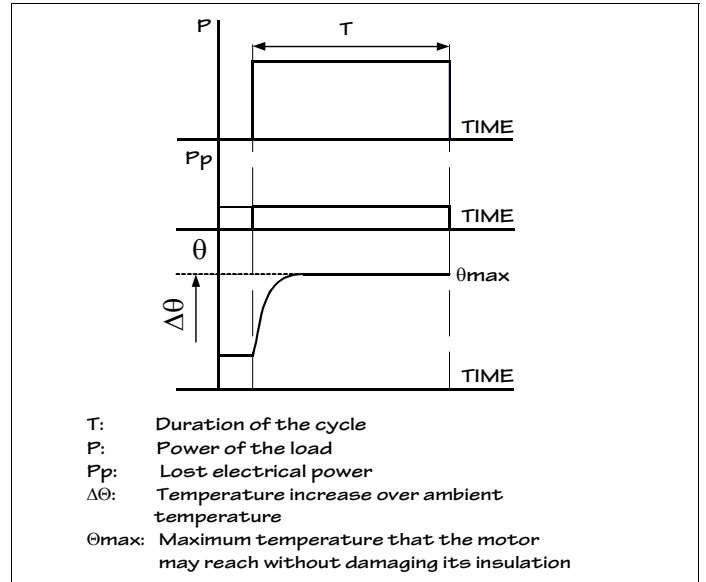

S6. S6 duty cycle (intermittent operation). Uninterrupted periodic service with intermittent load, also called "continuous cycle with intermittent load". It consists of a series of identical cycles that have a constant load time and another one without load. There is no resting (stopped) intervals. If no other value is indicated, the duty cycle with load will be referred to a time period of 10 minutes. Thus, S6-40% indicates:

tc=4 minutes with load
tv=6 minutes without load

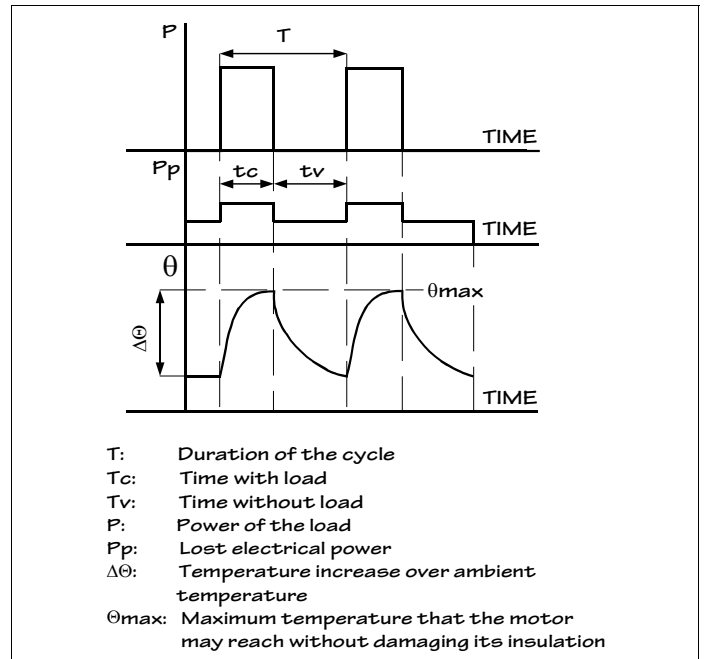

Motor limits. For induction motors, the speed and power values are limited for thermal and mechanical reasons. The maximum current is only limited by thermal characteristics of the motor windings.

❑ **Thermal limit.** Heat loss is stored in the motor and dissipated by cooling systems. The motor temperature depends, among other things, on the duty cycle with load. This critical motor temperature must never be exceeded. The characteristics for continuous cycle S1 and intermittent cycle S6-40% define the outputs allowed for an ambient temperature of up to 40°C. For this case, the winding temperature increase is about 100°C.

❑ **Mechanical limit.** The mechanical speed limit must never be exceeded. Exceeding this value may damage the roller bearings, the short-circuit ring of the rotor, ...

FM7 MOTORS

GENERAL CHARACTERISTICS

These motors have been manufactured in accordance with the European regulations EN 60204-1 and EN 60034 as instructed by the European Directive 2006/95/EC on Low Voltage (LVD).

Motor type	Induction. Squirrel cage
Thermal protection	NTC thermistor
Balancing	On E01 and E02 series Standard degree of vibration: V5/V10 Optional degree of vibration: V3/V5 On E03 and HS3 series Standard degree of vibration: V3
Mounting	On E01 and E02 series Horizontal: IM B3 - IM B5 - IM B35 Vertical: IM V1 - IM V5 - IM V15 On E03 and HS3 series Horizontal: IM B5 Vertical: IM V1
Electric winding insulation	Class F (155°C/311°F)
Degree of protection	IP 44
Storage temperature	0°C/60°C (32°F/140°F)
Permitted ambient temp.	0°C/40°C (32°F/104°F)
Working ambient humidity	95% max (non condensing)
Recommended maximum altitude	1000 m (3281 ft) max. over sea level
Fan	400 V AC three-phase (50/60 Hz). Independent supply voltage
Resistance of the isolation voltage	1800 V AC in 1 min.
Isolation resistance	500 V DC, 10 MΩ min.
Feedback	Magnetic encoder (standard) "C" axis encoder (optional)
Meets EC regulation	IEC 34-1

The "F" classification of the winding insulation is based on its capability to run at maximum temperature.

This temperature 155°C (311°F) represents the maximum running temperature for the winding. In other words, if the motor ran 40 hrs a week in a clean and dry environment, its life expectancy would be 10 to 20 years before the insulation deteriorates due to the point that it can no longer withstand the applied voltage.

TEMPERATURE SENSOR

The temperature sensor have a negative temperature coefficient (NTC) and they should be used in control and measurement systems within a range between -50°C (-58°F) and 200°C (392°F).

Sensor type	NTC thermistor
Resistance at 20°C (68°F)	10 kΩ
Resistance at 100°C (212°F)	750 Ω
Sensor connection	Feedback cable

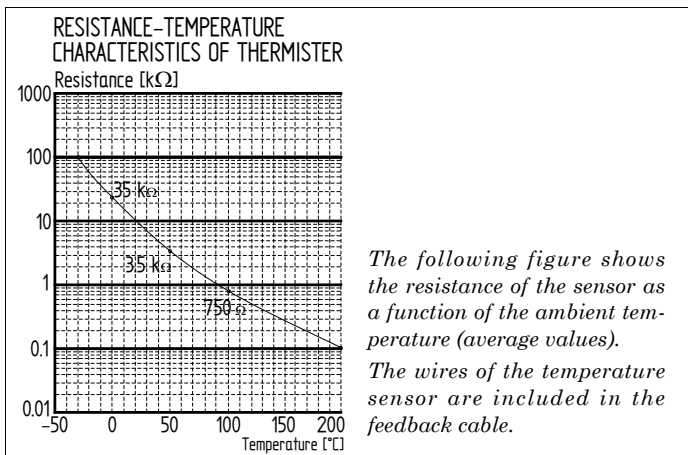

STRUCTURE

The structure of the motor is shown below.

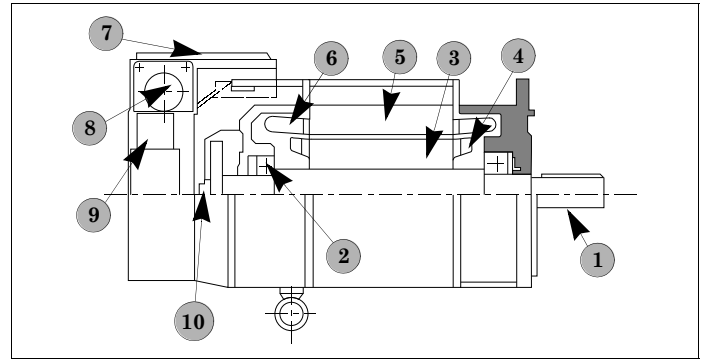

1	Shaft	6	Stator winding
2	Ball bearing	7	Terminal box
3	Rotor	8	Power connector
4	Short-circuit ring of the rotor	9	Cooling fan
5	Stator	10	Encoder

TERMINAL BOX. LAYOUT OF THE CONNECTION TERMINAL

The layout of the terminals in the box on top of the motor depends on the type of motor. The top image shows the terminal box on the motor series FM7-□□□□-□□□□-E01 and FM7-□□□□-□□□□-E02. The bottom image shows the terminal box on the motor series FM7-D□□□-S1D0-E03 and FM7-D□□□-S1D0-HS3.

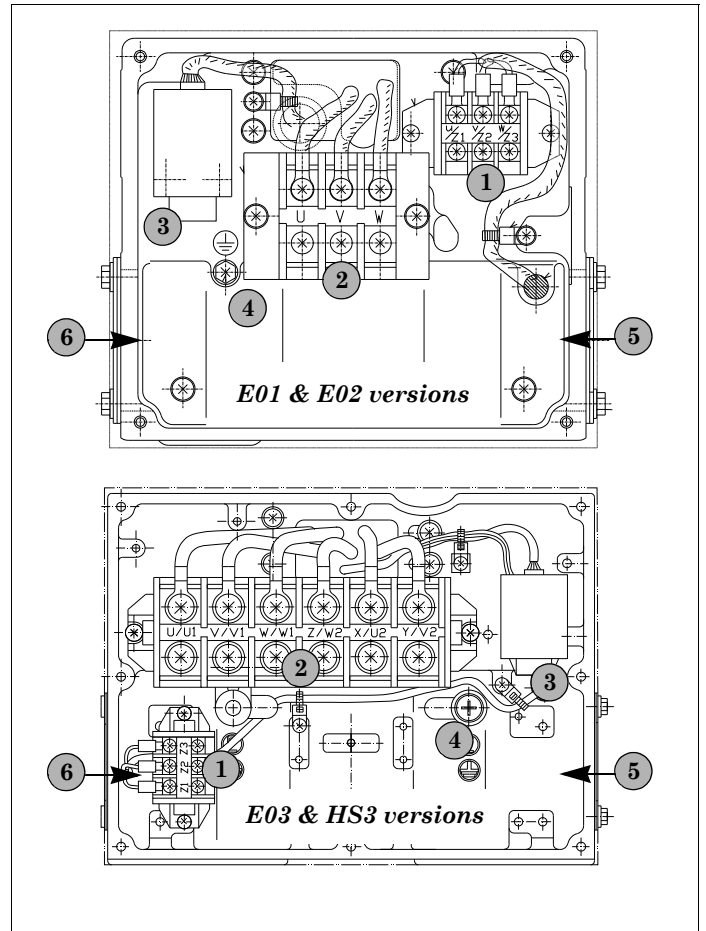

1	FAN connection	4	Ground bolt
2	MOTOR connection	5	Cable input-1
3	ENCODER connection	6	Cable input-2

TECHNICAL DATA AND CHARACTERISTICS CURVES

E01 and E02 series

The following figures show the torque and power characteristics for motor versions E01 and E02. Version E02 differs from E01 in the maximum number of rpm that the motor can reach. Thus, the graph are whose shaded area is lighter represents the behavior for version E01 and the darker area expands its rpm range.

Note that not all motor models have both versions; some of them only come in version E01 (FM7-A110, FM7-A300, FM7-A370, FM7-B220, FM7-B280 and FM7-E600). The rest come in both versions.

Note that the value of weight B/P (flange/foot) indicated in the data table indicates the weight depending on whether it is a flange or foot mounted model.

Motors whose **maximum speed ≥ 8000 rev/min** are recommended to have a keyless shaft and be balanced under these conditions.

Their power and torque graphs are shown here for duty cycles S1 and S6-40% (duty cycle of 10 minutes). The tables accompanying the graphs show the technical data for each model.

The AC motors of the FM7 series for main-spindle drives must be fanned all the time while running regardless of their duty cycles.

FM7-A075-□□□□-E0□

Rated power	Rated speed	Rated torque	Rated current	Max. speed		Inertia	Weight B/P
				E01	E02		
P_N (kW)	n_N (1/min)	M_N (N·m)	I_N (Arms)	n_{max} (1/min)		J (kg·cm ²)	P (kg)
7.5	1500	47.7	19.8	9000	10000	260	59/64

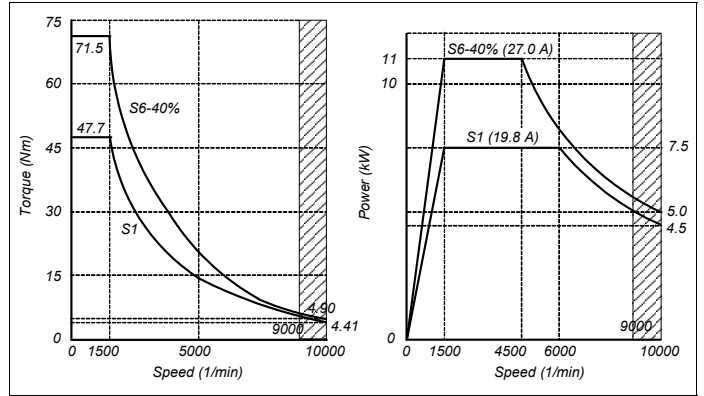

FM7-A037-□□□□-E0□

Rated power	Rated speed	Rated torque	Rated current	Max. speed		Inertia	Weight B/P
				E01	E02		
P_N (kW)	n_N (1/min)	M_N (N·m)	I_N (Arms)	n_{max} (1/min)		J (kg·cm ²)	P (kg)
3.7	1500	23.5	12.4	9000	12000	140	47/49

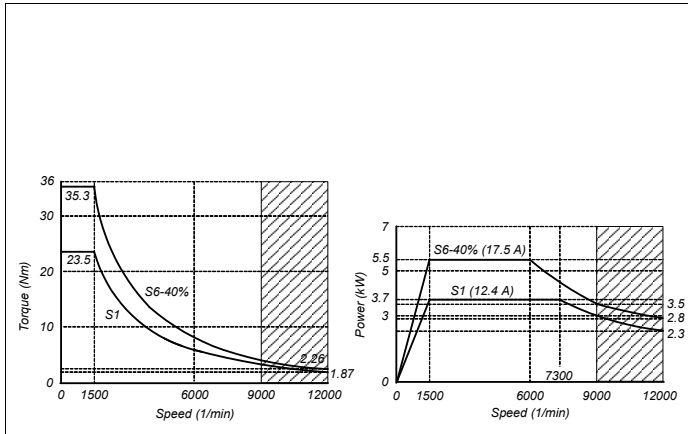

FM7-A090-□□□□-E0□

Rated power	Rated speed	Rated torque	Rated current	Max. speed		Inertia	Weight B/P
				E01	E02		
P_N (kW)	n_N (1/min)	M_N (N·m)	I_N (Arms)	n_{max} (1/min)		J (kg·cm ²)	P (kg)
9.0	1500	57.4	25.1	9000	10000	330	68/73

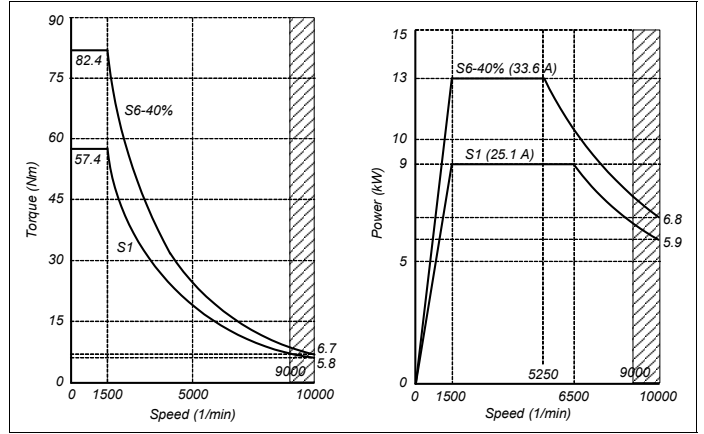

FM7-A055-□□□□-E0□

Rated power	Rated speed	Rated torque	Rated current	Max. speed		Inertia	Weight B/P
				E01	E02		
P_N (kW)	n_N (1/min)	M_N (N·m)	I_N (Arms)	n_{max} (1/min)		J (kg·cm ²)	P (kg)
5.5	1500	35.0	14.6	9000	10000	210	52/56

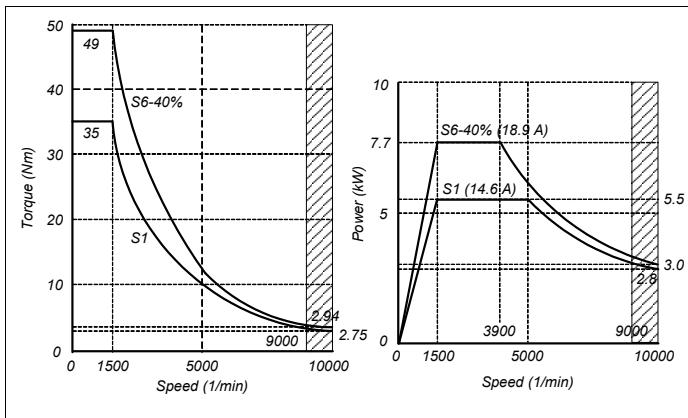

FM7-A110-□□□□-E0□

Rated power	Rated speed	Rated torque	Rated current	Max. speed		Inertia	Weight B/P
				E01	E02		
P_N (kW)	n_N (1/min)	M_N (N·m)	I_N (Arms)	n_{max} (1/min)		J (kg·cm ²)	P (kg)
11.0	1500	70.0	28.0	9000	10000	690	94/110

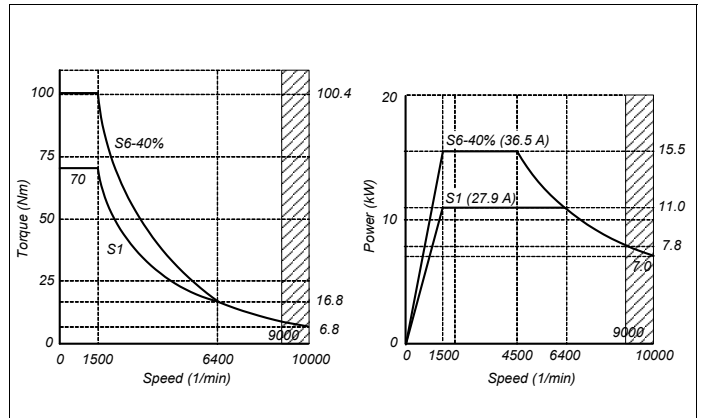

FM7-A150-□□□□-E0□

Rated power	Rated speed	Rated torque	Rated current	Max. speed		Inertia	Weight B/P
				E01	E02		
P_N (kW)	n_N (1/min)	M_N (N·m)	I_N (Arms)	n_{max} (1/min)		J (kg·cm ²)	P (kg)
15.0	1500	95.5	39.3	8000	9000	690	94/110

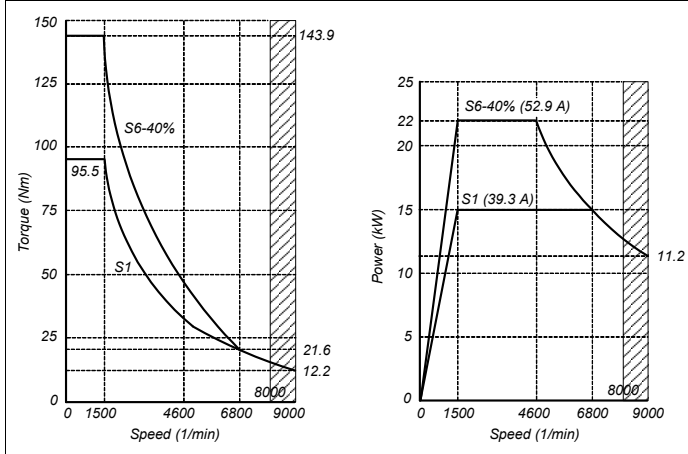

FM7-A300-□□□□-E01

Rated power	Rated speed	Rated torque	Rated current	Max. speed		Inertia	Weight B/P
				E01	E02		
P_N (kW)	n_N (1/min)	M_N (N·m)	I_N (Arms)	n_{max} (1/min)		J (kg·cm ²)	P (kg)
30.0	1500	191.0	82.1	6500	-	2310	220/230

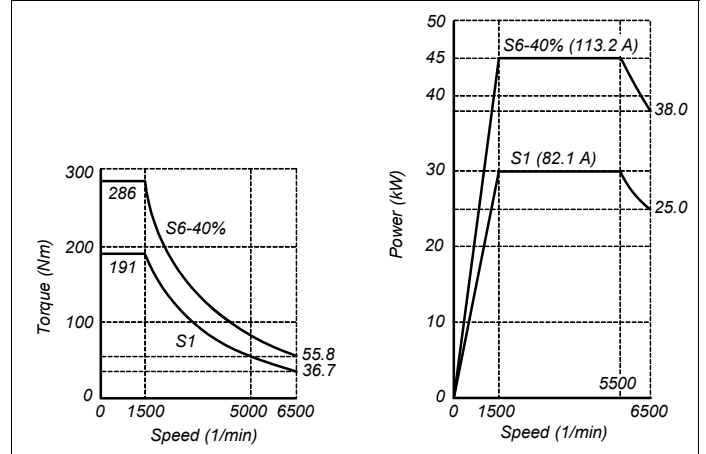

FM7-A185-□□□□-E0□

Rated power	Rated speed	Rated torque	Rated current	Max. speed		Inertia	Weight B/P
				E01	E02		
P_N (kW)	n_N (1/min)	M_N (N·m)	I_N (Arms)	n_{max} (1/min)		J (kg·cm ²)	P (kg)
18.5	1500	117.8	47.4	8000	9000	890	120/130

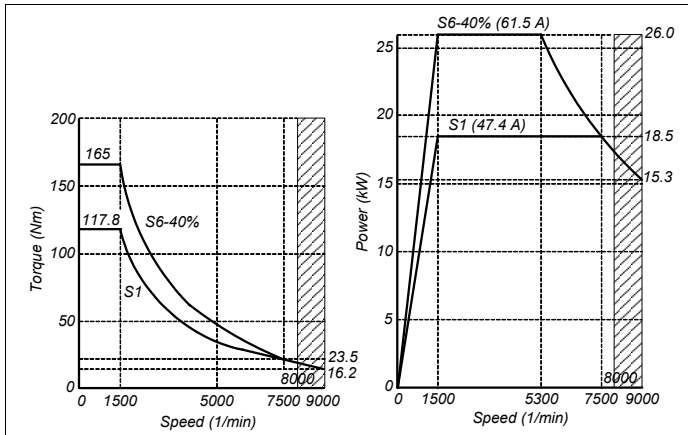

FM7-A370-□□□□-E01

Rated power	Rated speed	Rated torque	Rated current	Max. speed		Inertia	Weight B/P
				E01	E02		
P_N (kW)	n_N (1/min)	M_N (N·m)	I_N (Arms)	n_{max} (1/min)		J (kg·cm ²)	P (kg)
37.0	1500	235.0	90.0	6500	-	2660	250/260

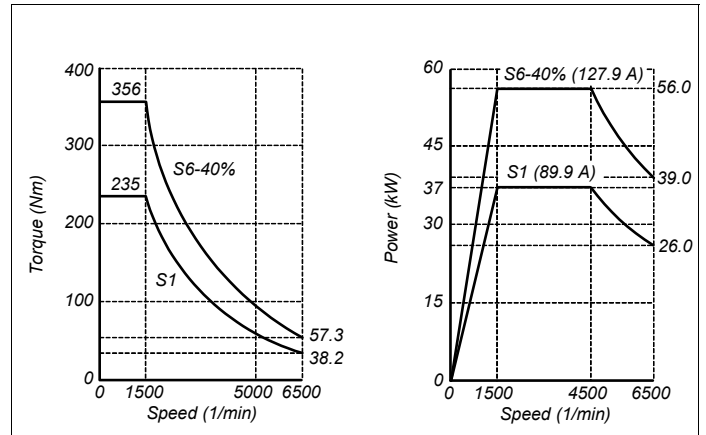

FM7-A220-□□□□-E0□

Rated power	Rated speed	Rated torque	Rated current	Max. speed		Inertia	Weight B/P
				E01	E02		
P_N (kW)	n_N (1/min)	M_N (N·m)	I_N (Arms)	n_{max} (1/min)		J (kg·cm ²)	P (kg)
22.0	1500	140.0	61.4	8000	9000	1080	135/145

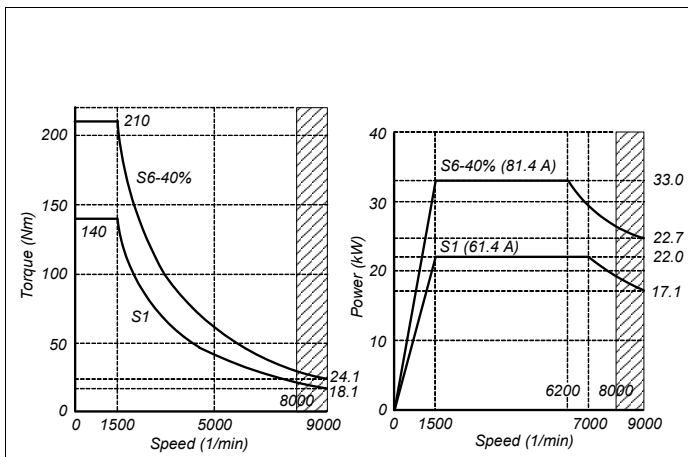

FM7-A510-□□□□-E0□

Rated power	Rated speed	Rated torque	Rated current	Max. speed		Inertia	Weight B/P
				E01	E02		
P_N (kW)	n_N (1/min)	M_N (N·m)	I_N (Arms)	n_{max} (1/min)		J (kg·cm ²)	P (kg)
51.0	1500	325.0	115.1	5000	6000	4730	340/350

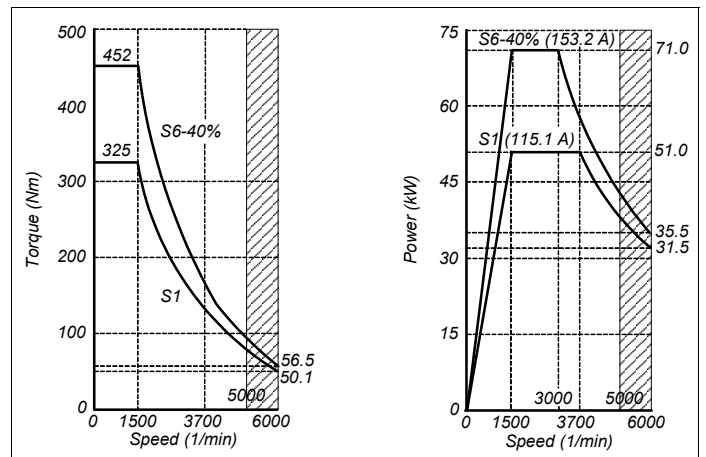

FM7-B120-□□□□-E0□

Rated power	Rated speed	Rated torque	Rated current	Max. speed		Inertia	Weight B/P
				E01	E02		
P_N (kW)	n_N (1/min)	M_N (N·m)	I_N (Arms)	n_{max} (1/min)		J (kg·cm ²)	P (kg)
12.0	1000	114.6	35.0	8000	9000	890	120/130

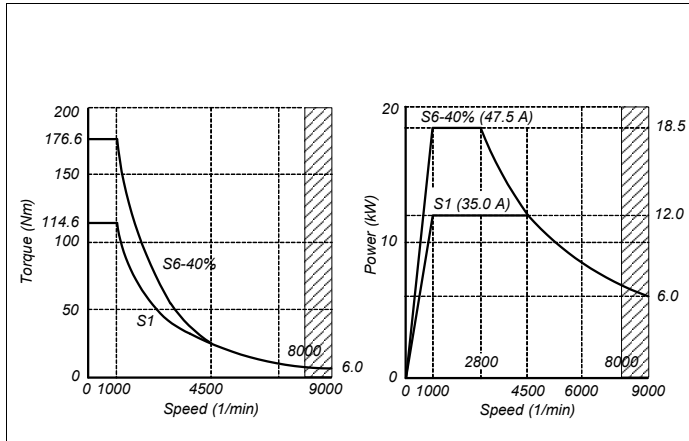

FM7-B280-□□□□-E01

Rated power	Rated speed	Rated torque	Rated current	Max. speed		Inertia	Weight B/P
				E01	E02		
P_N (kW)	n_N (1/min)	M_N (N·m)	I_N (Arms)	n_{max} (1/min)		J (kg·cm ²)	P (kg)
28.0	1000	267.4	78.2	6500	-	2660	250/260

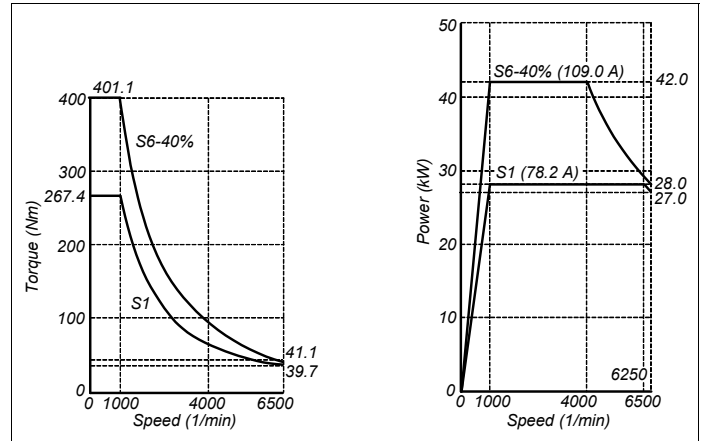

FM7-B170-□□□□-E0□

Rated power	Rated speed	Rated torque	Rated current	Max. speed		Inertia	Weight B/P
				E01	E02		
P_N (kW)	n_N (1/min)	M_N (N·m)	I_N (Arms)	n_{max} (1/min)		J (kg·cm ²)	P (kg)
17.0	1000	162.0	47.2	8000	9000	1080	135/145

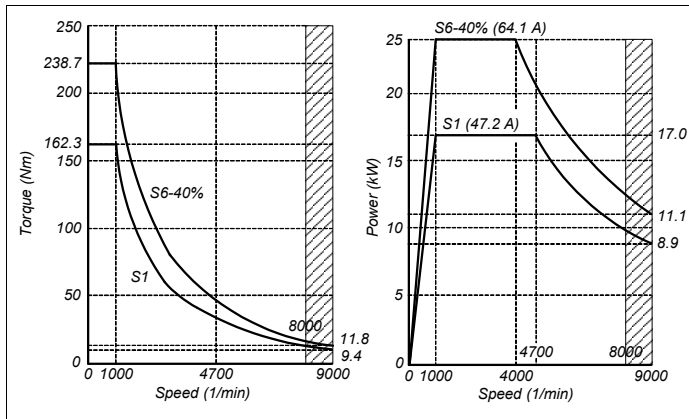

FM7-C215-□□□□-E0□

Rated power	Rated speed	Rated torque	Rated current	Max. speed		Inertia	Weight B/P
				E01	E02		
P_N (kW)	n_N (1/min)	M_N (N·m)	I_N (Arms)	n_{max} (1/min)		J (kg·cm ²)	P (kg)
21.5	500	410.6	87.8	5000	6000	4730	340/350

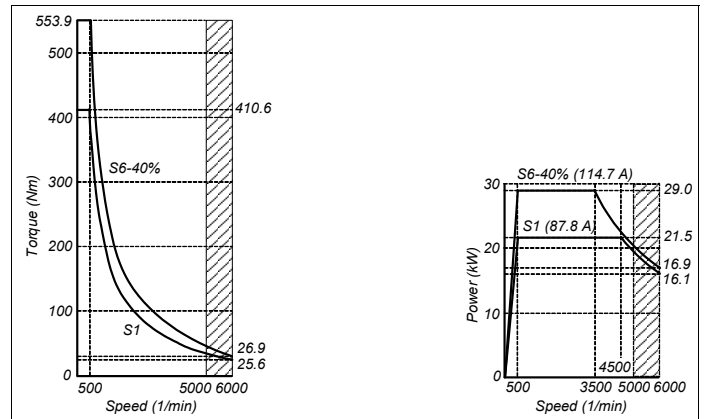

FM7-B220-□□□□-E01

Rated power	Rated speed	Rated torque	Rated current	Max. speed		Inertia	Weight B/P
				E01	E02		
P_N (kW)	n_N (1/min)	M_N (N·m)	I_N (Arms)	n_{max} (1/min)		J (kg·cm ²)	P (kg)
22.0	1000	210.0	64.9	6500	-	2310	220/230

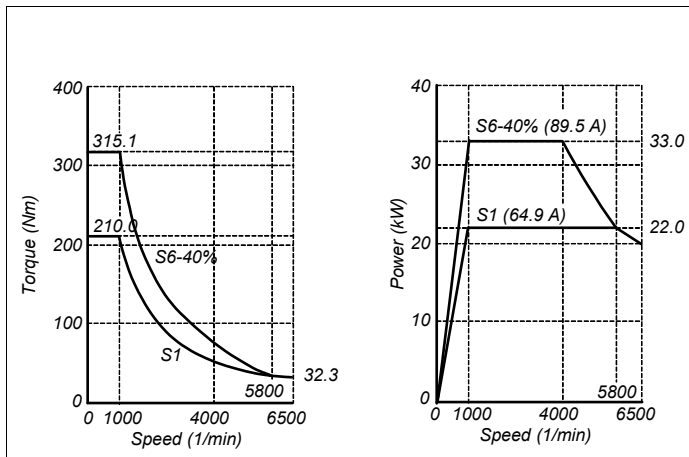

FM7-C270-□□□□-E0□

Rated power	Rated speed	Rated torque	Rated current	Max. speed		Inertia	Weight B/P
				E01	E02		
P_N (kW)	n_N (1/min)	M_N (N·m)	I_N (Arms)	n_{max} (1/min)		J (kg·cm ²)	P (kg)
27.0	500	515.7	116.9	5000	6000	5480	380/390

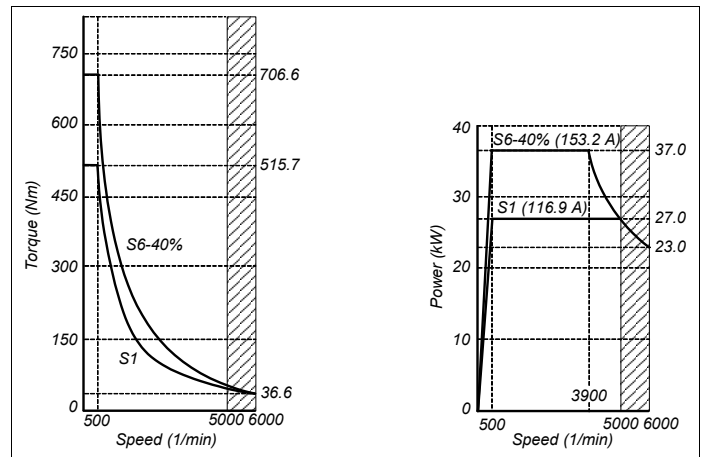

FM7-E600-C□B□-E01

Rated power	Rated speed	Rated torque	Rated current	Max. speed		Inertia	Weight B/P
				E01	E02		
P_N (kW)	n_N (1/min)	M_N (N·m)	I_N (Arms)	n_{max} (1/min)		J (kg·cm ²)	B/P/B+P (kg)
60.0	1250	458.4	117.4	5000	-	8720	525/540/545

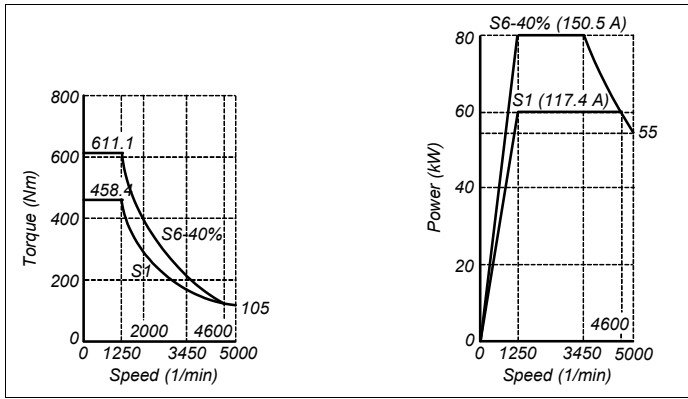

FM7-D110-S1D0-E03

Connection type	Rated power	Rated speed	Rated torque	Rated current	Max. speed	Inertia	Weight (B)
					E03		
▲	P_N (kW)	n_N (1/min)	M_N (N·m)	I_N (Arms)	n_{max} (1/min)	J (kg·cm ²)	P (kg)
	11.0	1500	70.0	38.0	12000	690	110
△	11.0	4000	26.3	40.0	12000	690	110

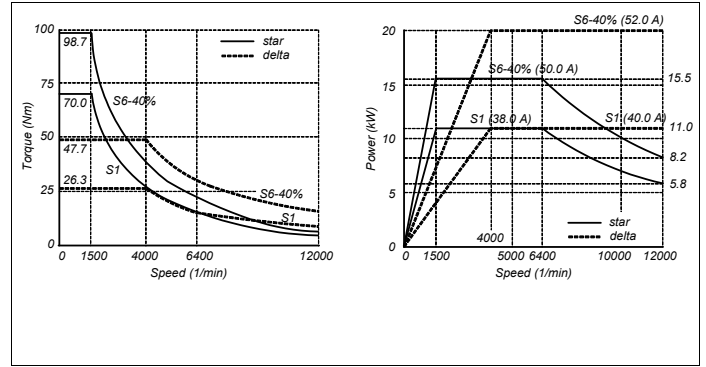

E03 and HS3 series

The following figures show the torque and power characteristics for motor versions E03 and HS3. The HS3 has a hollow shaft for cooling the spindle tool. Higher speeds may be reached with these FM7 motor versions those mentioned earlier. Their windings may be connected in star or triangle to obtain constant power either at low or high rpm respectively.

FM7-D055-S1D0-E03

Connection type	Rated power	Rated speed	Rated torque	Rated current	Max. speed	Inertia	Weight (B)
					E03		
▲	P_N (kW)	n_N (1/min)	M_N (N·m)	I_N (Arms)	n_{max} (1/min)	J (kg·cm ²)	P (kg)
	5.5	1500	35.0	20.3	15000	210	67
△	5.5	4000	13.1	20.7	15000	210	67

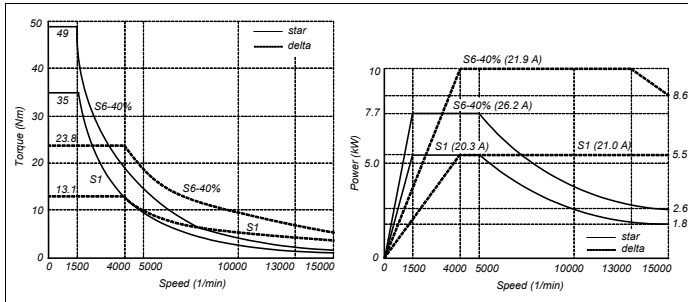

FM7-D150-S1D0-E03

Connection type	Rated power	Rated speed	Rated torque	Rated current	Max. speed	Inertia	Weight (B)
					E03		
▲	P_N (kW)	n_N (1/min)	M_N (N·m)	I_N (Arms)	n_{max} (1/min)	J (kg·cm ²)	P (kg)
	15.0	1500	95.5	46.4	12000	690	110
△	15.0	4000	35.8	45.7	12000	690	110

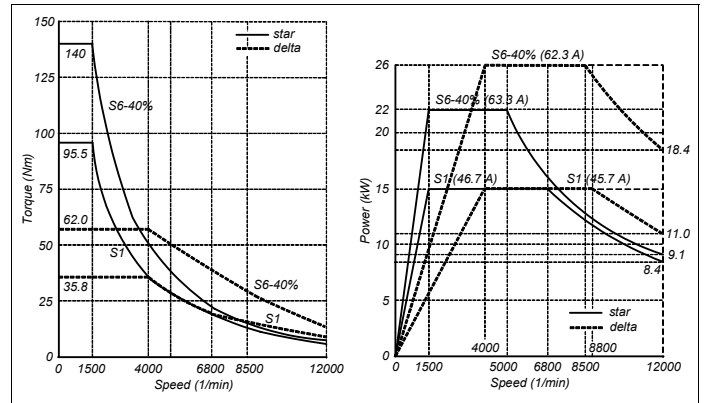

FM7-D075-S1D0-E03

Connection type	Rated power	Rated speed	Rated torque	Rated current	Max. speed	Inertia	Weight (B)
					E03		
▲	P_N (kW)	n_N (1/min)	M_N (N·m)	I_N (Arms)	n_{max} (1/min)	J (kg·cm ²)	P (kg)
	7.5	1500	47.7	26.5	15000	260	74
△	7.5	4000	17.9	25.8	15000	260	74

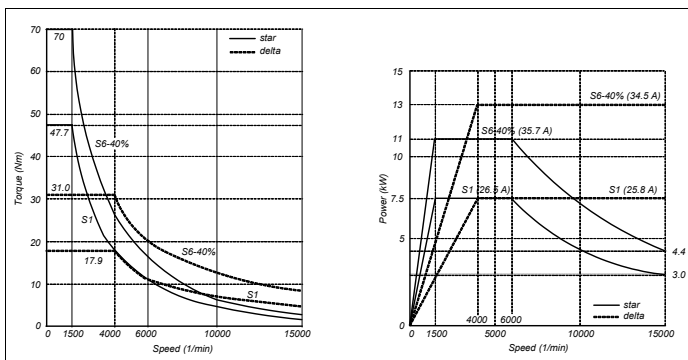

FM7-D185-S1D0-E03

Connection type	Rated power	Rated speed	Rated torque	Rated current	Max. speed	Inertia	Weight (B)
					E03		
▲	P_N (kW)	n_N (1/min)	M_N (N·m)	I_N (Arms)	n_{max} (1/min)	J (kg·cm ²)	P (kg)
	18.5	1500	117.8	49.2	12000	890	135
△	18.5	4000	44.2	49.2	12000	890	135

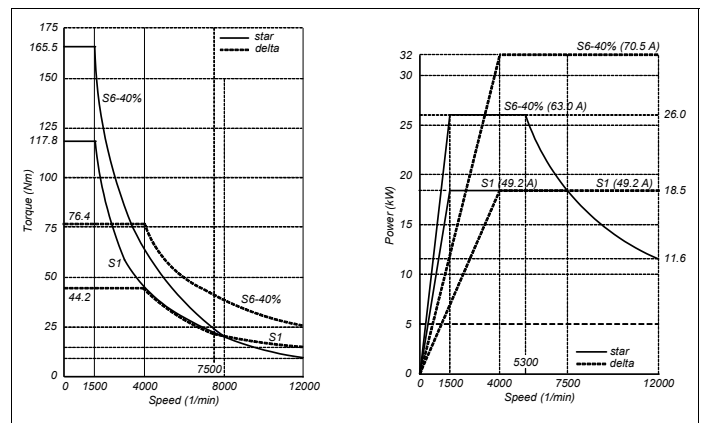

FM7-D220-S1D0-E03

Connection type	Rated power	Rated speed	Rated torque	Rated current	Max. speed	Inertia	Weight (B)
	P_N (kW)	n_N (1/min)	M_N (N·m)	I_N (Arms)	n_{max} (1/min)		
▲	22.0	1500	140.1	62.3	12000	1080	150
△	22.0	4000	52.2	61.7	12000	1080	150

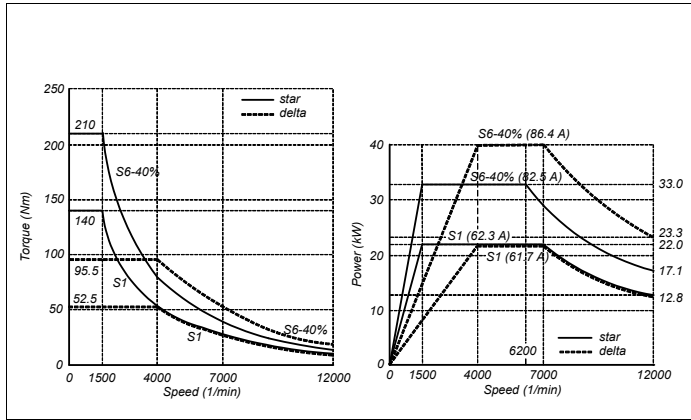

FM7-D185-S1D0-HS3

Connection type	Rated power	Rated speed	Rated torque	Rated current	Max. speed	Inertia	Weight (B)
	P_N (kW)	n_N (1/min)	M_N (N·m)	I_N (Arms)	n_{max} (1/min)		
▲	18.5	1500	117.8	49.2	12000	890	140
△	18.5	4000	44.2	49.2	12000	890	140

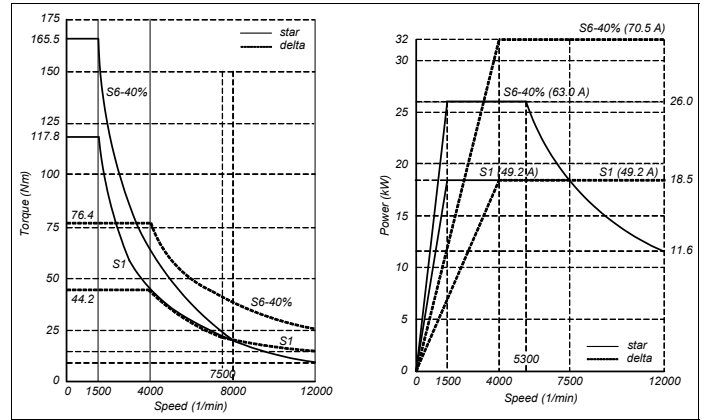

FM7-D075-S1D0-HS3

Connection type	Rated power	Rated speed	Rated torque	Rated current	Max. speed	Inertia	Weight (B)
	P_N (kW)	n_N (1/min)	M_N (N·m)	I_N (Arms)	n_{max} (1/min)		
▲	7.5	1500	47.7	26.5	15000	260	77
△	7.5	4000	17.9	25.8	15000	260	77

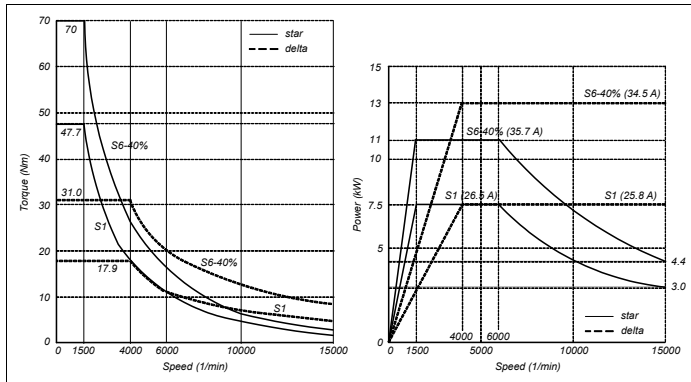

FM7-D220-S1D0-HS3

Connection type	Rated power	Rated speed	Rated torque	Rated current	Max. speed	Inertia	Weight (B)
	P_N (kW)	n_N (1/min)	M_N (N·m)	I_N (Arms)	n_{max} (1/min)		
▲	22.0	1500	140.1	62.3	12000	1080	155
△	22.0	4000	52.2	61.7	12000	1080	155

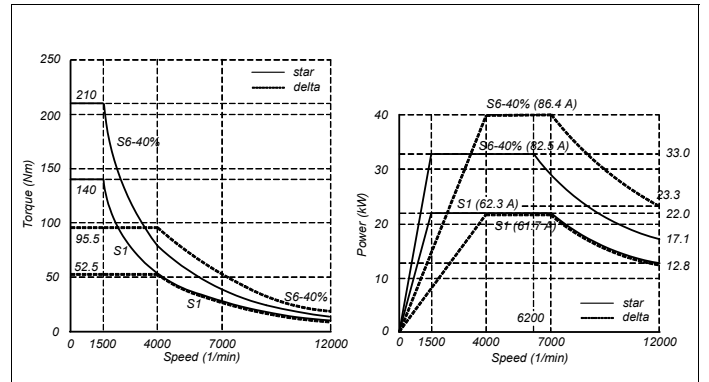

FM7-D110-S1D0-HS3

Connection type	Rated power	Rated speed	Rated torque	Rated current	Max. speed	Inertia	Weight (B)
	P_N (kW)	n_N (1/min)	M_N (N·m)	I_N (Arms)	n_{max} (1/min)		
▲	11.0	1500	70.0	38.0	12000	690	115
△	11.0	4000	26.3	40.0	12000	690	115

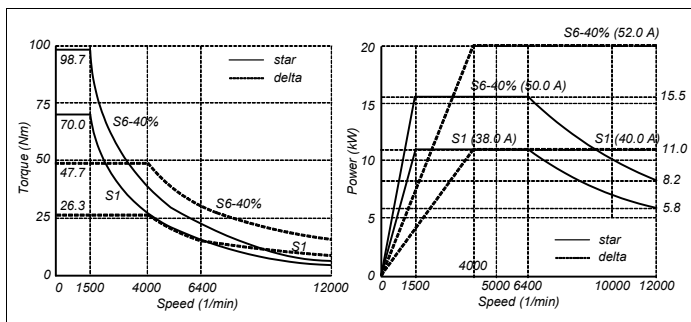

DIMENSIONS

FM7. E01/E02 series. Foot mounting

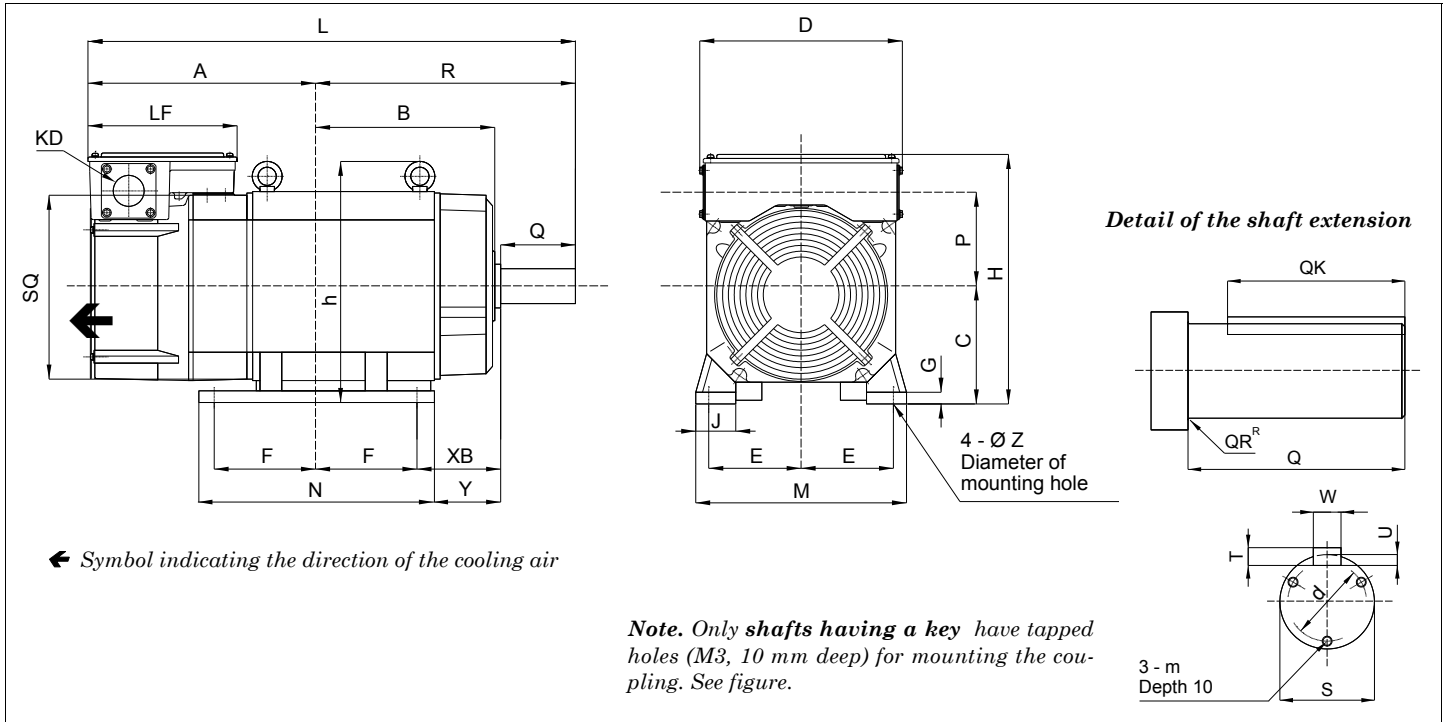

Units in mm	A	B	C	D	E	F	G	H	h	J	KD	L	M	N	P	R	XB	Y	Z	SQ
FM7-A037-□3□□-E0□	324.0	113.0	100	174	80.0	70.0	9	250	-	34	34.0	499.0	188	168	110.5	175.0	45	31	12	174
FM7-A055-□3□□-E0□	286.0	117.0	112	204	95.0	50.0	10	269	247.0	75	42.5	486.0	220	129	114.0	200.0	70	55	12	204
FM7-A075-□3□□-E0□	296.0	137.0	112	204	95.0	70.0	10	269	247.0	75	42.5	546.0	220	177	114.0	250.0	70	55	12	204
FM7-A090-□3□□-E0□	317.0	156.0	112	204	95.0	89.0	10	269	247.0	75	42.5	586.0	220	215	114.0	269.0	70	55	12	204
FM7-A110-□3□□-E0□	264.0	196.0	160	279	127.0	89.0	16	343	331.5	55	42.5	571.0	290	223	131.0	307.0	108	84	15	260
FM7-A150-□3□□-E0□	264.0	196.0	160	279	127.0	89.0	16	343	331.5	55	42.5	571.0	290	223	131.0	307.0	108	84	15	260
FM7-A185-□3□□-E0□	310.0	212.0	160	279	127.0	105.0	16	343	331.5	55	42.5	633.0	290	255	131.0	323.0	108	84	15	260
FM7-A220-□3□□-E0□	313.5	246.5	160	279	127.0	139.5	16	343	331.5	55	42.5	671.0	290	324	131.0	357.5	108	84	15	260
FM7-A300-□3□□-E0□	381.0	246.0	180	320	139.5	127.0	16	407	401.0	55	61.0	769.0	320	298	163.5	388.0	121	99	19	320
FM7-A370-□3□□-E0□	421.0	246.0	180	320	139.5	127.0	16	407	401.0	55	61.0	809.0	320	298	163.5	388.0	121	99	19	320
FM7-A510-□3□□-E0□	398.0	302.0	225	388	178.0	155.5	21	540	480.0	75	61.0	842.5	420	425	235.5	444.5	149	73	24	380
FM7-B120-□3□□-E0□	310.0	212.0	160	279	127.0	105.0	16	343	331.5	55	42.5	633.0	290	255	131.0	323.0	108	84	15	260
FM7-B170-□3□□-E0□	313.5	246.5	160	279	127.0	139.5	16	343	331.5	55	42.5	671.0	290	324	131.0	357.5	108	84	15	260
FM7-B220-□3□□-E0□	381.0	246.0	180	320	139.5	127.0	16	407	401.0	55	61.0	769.0	320	298	163.5	388.0	121	99	19	320
FM7-B280-□3□□-E0□	421.0	246.0	180	320	139.5	127.0	16	407	401.0	55	61.0	809.0	320	298	163.5	388.0	121	99	19	320
FM7-C215-□3□□-E0□	398.0	302.0	225	388	178.0	155.5	21	540	480.0	75	61.0	842.5	420	425	235.5	444.5	149	73	24	380
FM7-C270-□3□□-E0□	429.0	321.0	225	388	178.0	174.5	21	540	480.0	75	61.0	892.5	420	465	235.5	463.5	149	73	24	380
FM7-E600-C3B□-E01	589.0	331.5	225	388	178.0	228.5	21	540	480.0	90	61.0	1065.5	420	590	235.5	476.5	108	65	24	380

Units in inches	A	B	C	D	E	F	G	H	h	J	KD	L	M	N	P	R	XB	Y	Z	SQ
FM7-A037-□3□□-E0□	12.76	4.45	3.94	6.85	3.15	2.76	0.35	9.84	-	1.34	1.34	19.65	7.40	6.61	4.35	6.89	1.77	1.22	0.47	6.85
FM7-A055-□3□□-E0□	11.26	4.61	4.41	8.03	3.74	1.97	0.39	10.59	9.72	2.95	1.67	19.13	8.66	5.08	4.49	7.87	2.76	2.16	0.47	8.03
FM7-A075-□3□□-E0□	11.65	5.39	4.41	8.03	3.74	2.76	0.39	10.59	9.72	2.95	1.67	21.50	8.66	6.97	4.49	9.84	2.76	2.16	0.47	8.03
FM7-A090-□3□□-E0□	12.48	6.14	4.41	8.03	3.74	3.50	0.39	10.59	9.72	2.95	1.67	21.50	8.66	8.46	4.49	10.59	2.76	2.16	0.47	8.03
FM7-A110-□3□□-E0□	10.39	7.72	6.30	11.00	5.00	3.50	0.63	13.50	13.05	2.16	1.67	22.48	11.42	8.78	5.16	12.09	4.25	3.31	0.59	10.24
FM7-A150-□3□□-E0□	10.39	7.72	6.30	11.00	5.00	3.50	0.63	13.50	13.05	2.16	1.67	22.48	11.42	8.78	5.16	12.09	4.25	3.31	0.59	10.24
FM7-A185-□3□□-E0□	12.20	8.35	6.30	11.00	5.00	4.13	0.63	13.50	13.05	2.16	1.67	24.92	11.42	10.04	5.16	12.72	4.25	3.31	0.59	10.24
FM7-A220-□3□□-E0□	12.34	9.70	6.30	11.00	5.00	5.49	0.63	13.50	13.05	2.16	1.67	26.42	11.42	12.76	5.16	14.07	4.25	3.31	0.59	10.24
FM7-A300-□3□□-E0□	15.00	9.69	7.09	12.60	5.49	5.00	0.63	16.02	15.79	2.16	2.40	30.28	12.60	11.73	6.44	15.28	4.76	3.90	0.75	12.60
FM7-A370-□3□□-E0□	16.57	9.69	7.09	12.60	5.49	5.00	0.63	16.02	15.79	2.16	2.40	31.85	12.60	11.73	6.44	15.28	4.76	3.90	0.75	12.60
FM7-A510-□3□□-E0□	15.67	11.90	8.86	15.30	7.01	6.12	0.83	21.26	18.90	2.95	2.40	33.17	16.54	16.73	9.27	17.50	5.87	2.87	0.94	14.96
FM7-B120-□3□□-E0□	12.20	8.35	6.30	11.00	5.00	4.13	0.63	13.50	13.05	2.16	42.5	24.92	11.42	10.04	5.16	12.72	4.25	3.31	0.59	10.24
FM7-B170-□3□□-E0□	12.34	9.70	6.30	11.00	5.00	5.49	0.63	13.50	13.05	2.16	42.5	26.42	11.42	12.76	5.16	14.07	4.25	3.31	0.59	10.24
FM7-B220-□3□□-E0□	15.00	9.69	7.09	12.60	5.49	5.00	0.63	16.02	15.79	2.16	2.40	30.28	12.60	11.73	6.44	15.28	4.76	3.90	0.75	12.60
FM7-B280-□3□□-E0□	16.57	9.69	7.09	12.60	5.49	5.00	0.63	16.02	15.79	2.16	2.40	31.85	12.60	11.73	6.44	15.28	4.76	3.90	0.75	12.60
FM7-C215-□3□□-E0□	15.67	11.90	8.86	15.30	7.01	6.12	0.83	21.26	18.90	2.95	2.40	33.17	16.54	16.73	9.27	17.50	5.87	2.87	0.94	14.96
FM7-C270-□3□□-E0□	16.89	12.60	8.86	15.30	7.01	6.87	0.83	21.26	18.90	2.95	2.40	35.14	16.54	18.31	9.27	18.25	5.87	2.87	0.94	14.96
FM7-E600-C3B□-E01	23.18	13.05	8.86	15.30	7.01	8.99	0.83	21.26	18.90	3.54	2.40	41.94	16.54	23.22	9.27	18.75	4.25	2.55	0.94	14.96

	Units in mm									Units in inches								
	Q	QK	QR	S	T	U	W	d	m	Q	QK	QR	S	T	U	W	d	m
FM7-A037-□3□□-E0□	60	45	1.0	28h6	7h11	4.0	8h9	22	M4	2.36	1.77	0.039	1.10h6	0.28h11	0.16	0.31h9	0.87	M4
FM7-A055-□3□□-E0□	80	70	2.0	32h6	8h11	5.0	10h9	22	M5	3.15	2.76	0.078	1.26h6	0.31h11	0.20	0.39h9	0.87	M5
FM7-A075-□3□□-E0□	110	90	0.5	48h6	9h11	5.5	14h9	40	M5	4.33	3.54	0.019	1.89h6	0.35h11	0.21	0.55h9	1.57	M5
FM7-A090-□3□□-E0□	110	90	0.5	48h6	9h11	5.5	14h9	40	M5	4.33	3.54	0.019	1.89h6	0.35h11	0.21	0.55h9	1.57	M5
FM7-A110-□3□□-E0□	110	90	1.0	48h6	9h11	5.5	14h9	40	M5	4.33	3.54	0.039	1.89h6	0.35h11	0.21	0.55h9	1.57	M5
FM7-A150-□3□□-E0□	110	90	1.0	48h6	9h11	5.5	14h9	40	M5	4.33	3.54	0.039	1.89h6	0.35h11	0.21	0.55h9	1.57	M5
FM7-A185-□3□□-E0□	110	90	1.0	48h6	9h11	5.5	14h9	40	M5	4.33	3.54	0.039	1.89h6	0.35h11	0.21	0.55h9	1.57	M5
FM7-A220-□3□□-E0□	110	90	1.0	48h6	9h11	5.5	14h9	40	M5	4.33	3.54	0.039	1.89h6	0.35h11	0.21	0.55h9	1.57	M5
FM7-A300-□3□□-E0□	140	110	2.0	60m6	11h11	7.0	18h9	50	M6	5.51	4.33	0.078	2.36m6	0.43h11	0.27	0.70h9	1.96	M6
FM7-A370-□3□□-E0□	140	110	2.0	60m6	11h11	7.0	18h9	50	M6	5.51	4.33	0.078	2.36m6	0.43h11	0.27	0.70h9	1.96	M6
FM7-A510-□3□□-E01	140	110	1.0	70m6	12h11	7.5	20h9	60	M6	5.51	4.33	0.039	2.75m6	0.47h11	0.29	0.78h9	2.36	M6
FM7-A510-□3□□-E02	140	110	2.0	60m6	11h11	7.0	18h9	50	M6	5.51	4.33	0.078	2.36m6	0.43h11	0.27	0.70h9	1.96	M6
FM7-B120-□3□□-E0□	110	90	1.0	48h6	9h11	5.5	14h9	40	M5	4.33	3.54	0.039	1.89h6	0.35h11	0.21	0.55h9	1.57	M5
FM7-B170-□3□□-E0□	110	90	1.0	48h6	9h11	5.5	14h9	40	M5	4.33	3.54	0.039	1.89h6	0.35h11	0.21	0.55h9	1.57	M5
FM7-B220-□3□□-E0□	140	110	2.0	60m6	11h11	7.0	18h9	50	M6	5.51	4.33	0.078	2.36m6	0.43h11	0.27	0.70h9	1.96	M6
FM7-B280-□3□□-E0□	140	110	2.0	60m6	11h11	7.0	18h9	50	M6	5.51	4.33	0.078	2.36m6	0.43h11	0.27	0.70h9	1.96	M6
FM7-C215-□3□□-E01	140	110	1.0	70m6	12h11	7.5	20h9	60	M6	5.51	4.33	0.039	2.75m6	0.47h11	0.29	0.78h9	2.36	M6
FM7-C215-□3□□-E02	140	110	2.0	60m6	11h11	7.0	18h9	50	M6	5.51	4.33	0.078	2.36m6	0.43h11	0.27	0.70h9	1.96	M6
FM7-C270-□3□□-E01	140	110	1.0	70m6	12h11	7.5	20h9	60	M6	5.51	4.33	0.039	2.75m6	0.47h11	0.29	0.78h9	2.36	M6
FM7-C270-□3□□-E02	140	110	2.0	60m6	11h11	7.0	18h9	50	M6	5.51	4.33	0.078	2.36m6	0.43h11	0.27	0.70h9	1.96	M6
FM7-E600-C3B□-E01	140	110	1.0	65m6	11h11	7.0	18h9	55	M6	5.51	4.33	0.039	2.56m6	0.43h11	0.27	0.70h9	2.16	M6

FM7. E01/E02 series. Foot and flange mounting

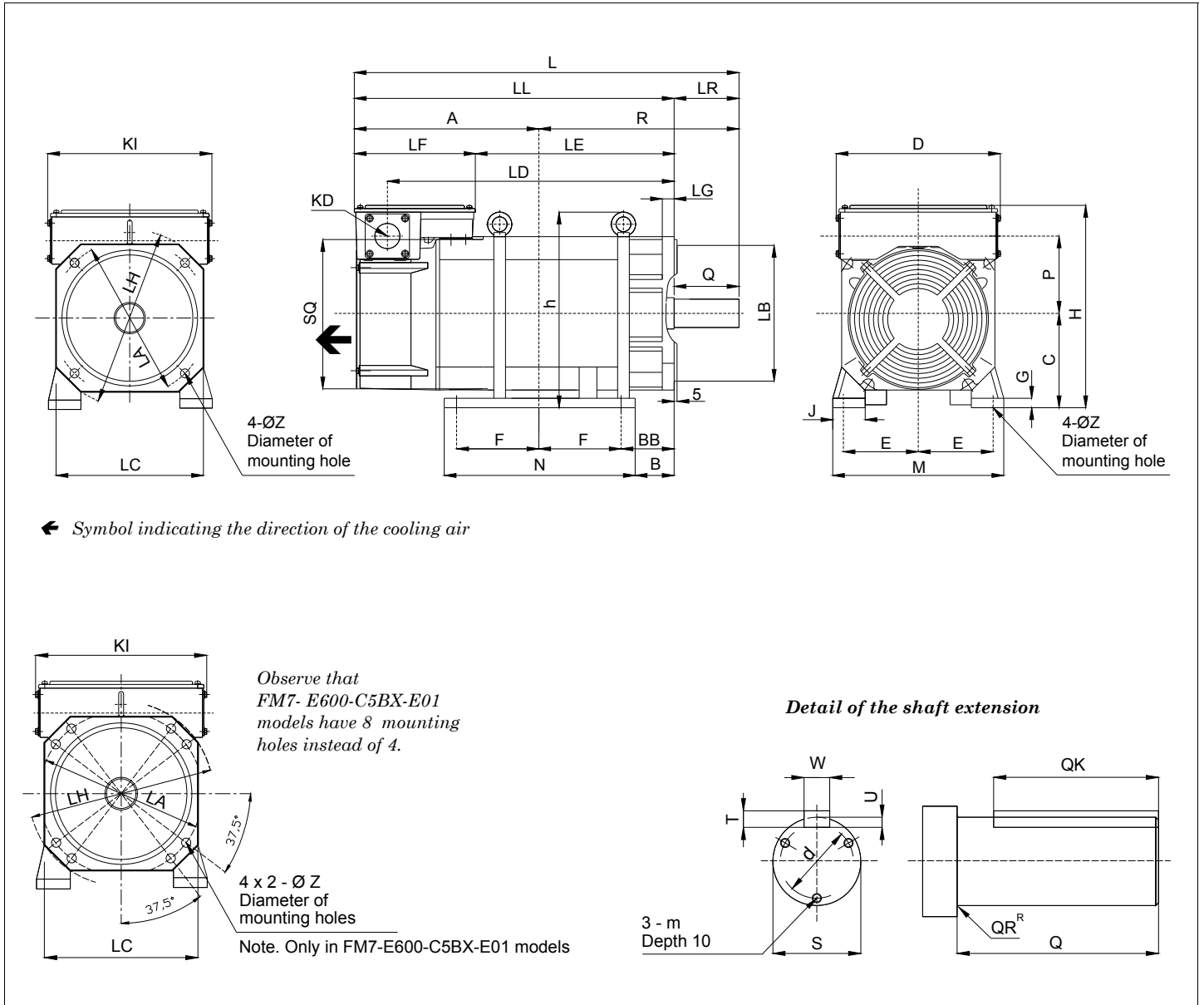

FM7. E01/E02 series. Flange mounting

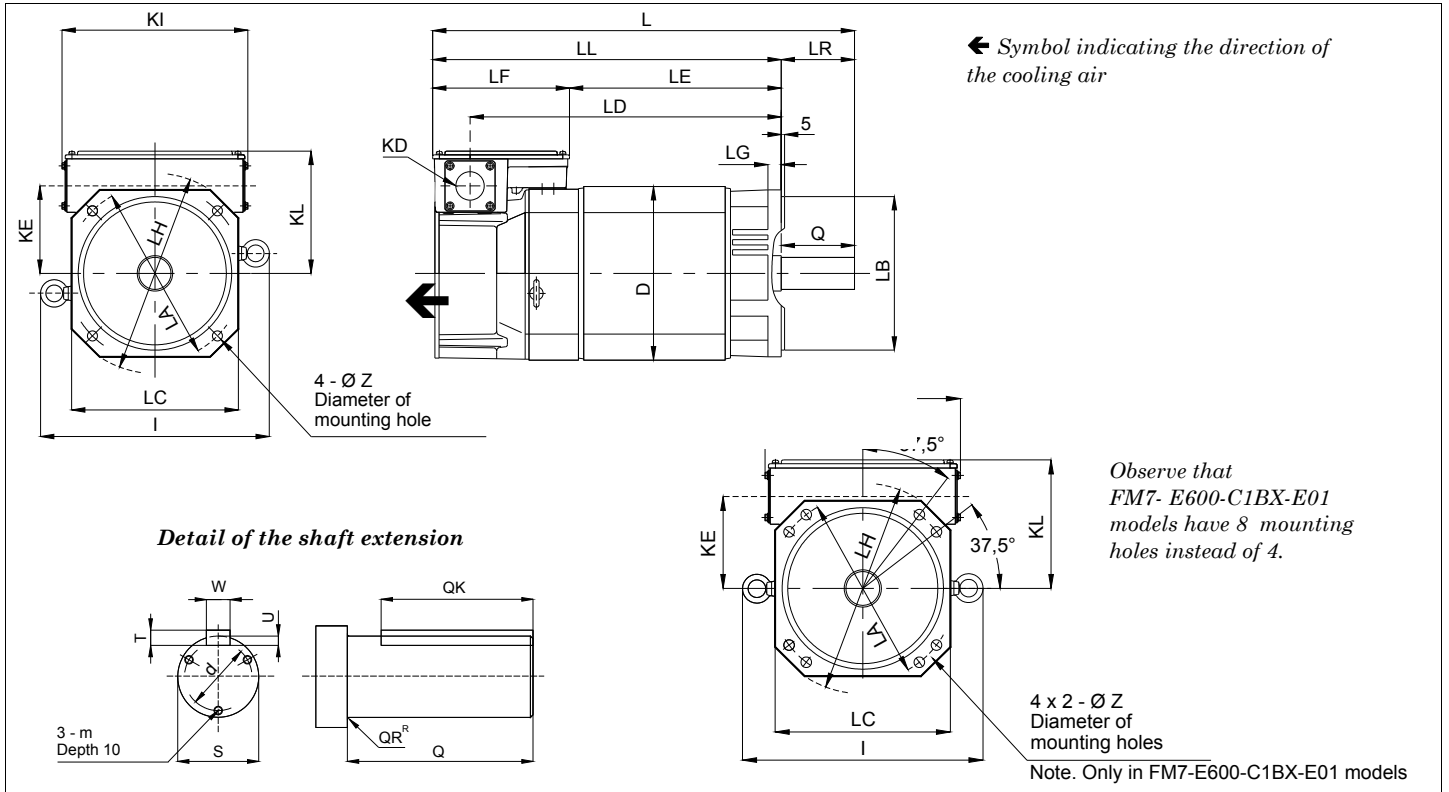

Units in mm	L	LA	LB	LC	LG	LH	LL	LR	LD	LE	LF	Z	D	I	KD	KL	KI	KE
FM7-A037-□1□□-E0□	499.0	185	150h7	174	12	220	407.0	60	399.0	214.0	225	11	174	-	34.0	150	174	110.5
FM7-A055-□1□□-E0□	486.0	215	180h7	204	16	250	406.0	80	354.0	227.0	170	15	204	270	42.5	158	204	114.0
FM7-A075-□1□□-E0□	546.0	215	180h7	204	16	250	436.0	110	384.0	257.0	171	15	204	270	42.5	158	204	114.0
FM7-A090-□1□□-E0□	586.0	215	180h7	204	16	250	476.0	110	424.0	297.0	171	15	204	270	42.5	158	204	114.0
FM7-A110-□1□□-E0□	571.0	265	230h7	250	20	300	461.0	110	404.5	256.0	205	15	260	343	42.5	183	279	131.0
FM7-A150-□1□□-E0□	571.0	265	230h7	250	20	300	461.0	110	404.5	256.0	205	15	260	343	42.5	183	279	131.0
FM7-A185-□1□□-E0□	633.0	265	230h7	250	20	300	523.0	110	466.5	318.0	205	15	260	343	42.5	183	279	131.0
FM7-A220-□1□□-E0□	671.0	265	230h7	250	20	300	561.0	110	504.5	355.0	205	15	260	343	42.5	183	279	131.0
FM7-A300-□1□□-E0□	769.0	350	300h7	320	20	385	629.0	140	557.5	362.0	261	19	320	440	61.0	227	320	163.5
FM7-A370-□1□□-E0□	809.0	350	300h7	320	20	385	669.0	140	597.5	402.0	261	19	320	440	61.0	227	320	163.5
FM7-A510-□1□□-E0□	847.0	400	350h7	370	22	450	707.0	140	632.5	430.0	277	24	380	504	61.0	315	388	235.5
FM7-B120-□1□□-E0□	633.0	265	230h7	250	20	300	523.0	110	466.5	318.0	205	15	260	343	42.5	183	279	131.0
FM7-B170-□1□□-E0□	671.0	265	230h7	250	20	300	561.0	110	504.5	355.0	205	15	260	343	42.5	181	250	131.0
FM7-B220-□1□□-E0□	769.0	350	300h7	320	20	385	629.0	140	557.5	362.0	261	19	320	440	61.0	227	320	163.5
FM7-B280-□1□□-E0□	809.0	350	300h7	320	20	385	669.0	140	597.5	402.0	261	19	320	440	61.0	227	320	163.5
FM7-C215-□1□□-E0□	847.0	400	350h7	370	22	450	707.0	140	632.5	430.0	277	24	380	504	61.0	315	388	235.5
FM7-C270-□1□□-E0□	897.0	400	350h7	370	22	450	757.0	140	682.5	480.0	277	24	380	504	61.0	315	388	235.5
FM7-E600-C1B□-E01	1065.5	400	350h7	370	22	450	925.5	140	851.0	648.5	277	24	380	526	61.0	315	388	235.5

Units in inches	L	LA	LB	LC	LG	LH	LL	LR	LD	LE	LF	Z	D	I	KD	KL	KI	KE
FM7-A037-□1□□-E0□	18.39	7.28	5.90h7	6.85	0.47	8.66	16.02	2.36	15.71	8.42	8.86	0.43	6.85	-	1.34	5.90	6.85	4.35
FM7-A055-□1□□-E0□	19.13	8.46	7.09h7	8.03	0.63	9.84	15.98	3.15	13.94	8.94	6.69	0.59	8.03	10.63	1.67	6.22	8.03	4.49
FM7-A075-□1□□-E0□	21.50	8.46	7.09h7	8.03	0.63	9.84	17.17	4.33	15.12	10.12	6.73	0.59	8.03	10.63	1.67	6.22	8.03	4.49
FM7-A090-□1□□-E0□	23.07	8.46	7.09h7	8.03	0.63	9.84	18.74	4.33	16.69	11.69	6.73	0.59	8.03	10.63	1.67	6.22	8.03	4.49
FM7-A110-□1□□-E0□	22.48	10.43	9.05h7	9.84	0.79	11.81	18.15	4.33	15.93	10.08	8.07	0.59	10.24	13.50	1.67	7.20	10.98	5.16
FM7-A150-□1□□-E0□	22.48	10.43	9.05h7	9.84	0.79	11.81	18.15	4.33	15.93	10.08	8.07	0.59	10.24	13.50	1.67	7.20	10.98	5.16
FM7-A185-□1□□-E0□	24.92	10.43	9.05h7	9.84	0.79	11.81	20.59	4.33	18.37	12.52	8.07	0.59	10.24	13.50	1.67	7.20	10.98	5.16
FM7-A220-□1□□-E0□	26.42	10.43	9.05h7	9.84	0.79	11.81	22.09	4.33	19.86	13.98	8.07	0.59	10.24	13.50	1.67	7.20	10.98	5.16
FM7-A300-□1□□-E0□	30.28	13.78	11.81h7	12.60	0.79	15.16	24.76	5.51	21.95	14.25	10.28	0.75	12.60	17.32	2.40	8.94	12.60	6.44
FM7-A370-□1□□-E0□	31.85	13.78	11.81h7	12.60	0.79	15.16	26.34	5.51	23.52	15.83	10.28	0.75	12.60	17.32	2.40	8.94	12.60	6.44
FM7-A510-□1□□-E0□	33.35	15.75	13.78h7	14.57	0.87	17.72	27.83	5.51	24.90	16.93	10.91	0.94	14.96	19.84	2.40	12.40	15.28	9.27
FM7-B120-□1□□-E0□	24.80	10.43	9.05h7	9.84	0.79	11.81	20.47	4.33	17.72	12.48	6.89	0.59	10.24	13.50	1.67	7.13	9.84	5.16
FM7-B170-□1□□-E0□	26.42	10.43	9.05h7	9.84	0.79	11.81	22.09	4.33	19.86	13.98	8.07	0.59	10.24	13.50	1.67	7.20	10.98	5.16
FM7-B220-□1□□-E0□	30.28	13.78	11.81h7	12.60	0.79	15.16	24.76	5.51	21.95	14.25	10.28	0.75	12.60	17.32	2.40	8.94	12.60	6.44
FM7-B280-□1□□-E0□	31.85	13.78	11.81h7	12.60	0.79	15.16	26.34	5.51	23.52	15.83	10.28	0.75	12.60	17.32	2.40	8.94	12.60	6.44
FM7-C215-□1□□-E0□	33.35	15.75	13.78h7	14.57	0.87	17.72	27.83	5.51	24.90	16.93	10.91	0.94	14.96	19.84	2.40	12.40	15.28	9.27
FM7-C270-□1□□-E0□	35.31	15.75	13.78h7	14.57	0.87	17.72	29.80	5.51	26.87	18.90	10.91	0.94	14.96	19.84	2.40	12.40	15.28	9.27
FM7-E600-C1B□-E01	41.94	15.75	13.78h7	14.57	0.87	17.72	36.43	5.51	33.50	25.53	10.91	0.94	14.96	20.70	2.40	12.40	15.28	9.27

	Units in mm									Units in inches								
	Q	QK	QR	S	T	U	W	d	m	Q	QK	QR	S	T	U	W	d	m
FM7-A037-□1□□-E0□	60	45	1.0	28h6	7h11	4.0	8h9	22	M4	2.36	1.77	0.039	1.10h6	0.28h11	0.16	0.31h9	0.87	M4
FM7-A055-□1□□-E0□	80	70	2.0	32h6	8h11	5.0	10h9	22	M5	3.15	2.76	0.078	1.26h6	0.31h11	0.20	0.39h9	0.87	M5
FM7-A075-□1□□-E0□	110	90	0.5	48h6	9h11	5.5	14h9	40	M5	4.33	3.54	0.019	1.89h6	0.35h11	0.21	0.55h9	1.57	M5
FM7-A090-□1□□-E0□	110	90	0.5	48h6	9h11	5.5	14h9	40	M5	4.33	3.54	0.019	1.89h6	0.35h11	0.21	0.55h9	1.57	M5
FM7-A110-□1□□-E0□	110	90	1.0	48h6	9h11	5.5	14h9	40	M5	4.33	3.54	0.039	1.89h6	0.35h11	0.21	0.55h9	1.57	M5
FM7-A150-□1□□-E0□	110	90	1.0	48h6	9h11	5.5	14h9	40	M5	4.33	3.54	0.039	1.89h6	0.35h11	0.21	0.55h9	1.57	M5
FM7-A185-□1□□-E0□	110	90	1.0	48h6	9h11	5.5	14h9	40	M5	4.33	3.54	0.039	1.89h6	0.35h11	0.21	0.55h9	1.57	M5
FM7-A220-□1□□-E0□	110	90	1.0	48h6	9h11	5.5	14h9	40	M5	4.33	3.54	0.039	1.89h6	0.35h11	0.21	0.55h9	1.57	M5
FM7-A300-□1□□-E0□	140	110	2.0	60m6	11h11	7.0	18h9	50	M6	5.51	4.33	0.078	2.36m6	0.43h11	0.27	0.70h9	1.96	M6
FM7-A370-□1□□-E0□	140	110	2.0	60m6	11h11	7.0	18h9	50	M6	5.51	4.33	0.078	2.36m6	0.43h11	0.27	0.70h9	1.96	M6
FM7-A510-□1□□-E01	140	110	1.0	70m6	12h11	7.5	20h9	60	M6	5.51	4.33	0.039	2.75m6	0.47h11	0.29	0.78h9	2.36	M6
FM7-A510-□1□□-E02	140	110	2.0	60m6	11h11	7.0	18h9	50	M6	5.51	4.33	0.078	2.36m6	0.43h11	0.27	0.70h9	1.96	M6
FM7-B120-□1□□-E0□	110	90	1.0	48h6	9h11	5.5	14h9	40	M5	4.33	3.54	0.039	1.89h6	0.35h11	0.21	0.55h9	1.57	M5
FM7-B170-□1□□-E0□	110	90	1.0	48h6	9h11	5.5	14h9	40	M5	4.33	3.54	0.039	1.89h6	0.35h11	0.21	0.55h9	1.57	M5
FM7-B220-□1□□-E0□	140	110	2.0	60m6	11h11	7.0	18h9	50	M6	5.51	4.33	0.078	2.36m6	0.43h11	0.27	0.70h9	1.96	M6
FM7-B280-□1□□-E0□	140	110	2.0	60m6	11h11	7.0	18h9	50	M6	5.51	4.33	0.078	2.36m6	0.43h11	0.27	0.70h9	1.96	M6
FM7-C215-□1□□-E01	140	110	1.0	70m6	12h11	7.5	20h9	60	M6	5.51	4.33	0.039	2.75m6	0.47h11	0.29	0.78h9	2.36	M6
FM7-C215-□1□□-E02	140	110	2.0	60m6	11h11	7.0	18h9	50	M6	5.51	4.33	0.078	2.36m6	0.43h11	0.27	0.70h9	1.96	M6
FM7-C270-□1□□-E01	140	110	1.0	70m6	12h11	7.5	20h9	60	M6	5.51	4.33	0.039	2.75m6	0.47h11	0.29	0.78h9	2.36	M6
FM7-C270-□1□□-E02	140	110	2.0	60m6	11h11	7.0	18h9	50	M6	5.51	4.33	0.078	2.36m6	0.43h11	0.27	0.70h9	1.96	M6
FM7-E600-C1B□-E01	140	110	1.0	65m6	11h11	7.0	18h9	55	M6	5.51	4.33	0.039	2.55m6	0.43h11	0.27	0.70h9	2.16	M6

FM7. E03 series. Flange mounting

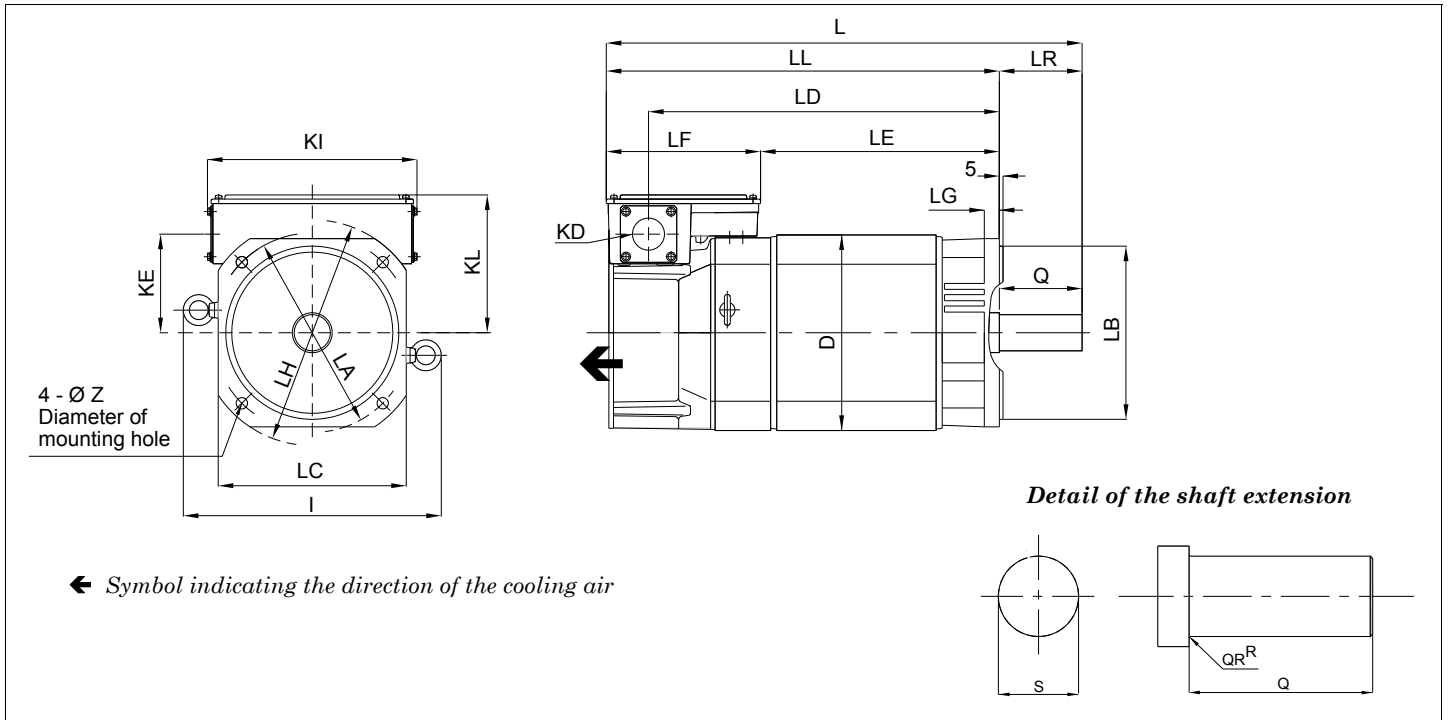

Units in mm	L	LA	LB	LC	LG	LH	LL	LR	LD	LE	LF	Z	D	I	KD	KL	KI	KE	Q	QR	S
FM7-D055-S1D0-E03	475	215	180h7	204	20	250	415	60	353	226	171	15	204	270	42.5	158	204	114	60	0.5	28h6
FM7-D075-S1D0-E03	506	215	180h7	204	20	250	446	60	401	256	190	15	204	270	42.5	164	250	114	60	0.5	28h6
FM7-D110-S1D0-E03	556	265	230h7	250	25	300	476	80	420	271	205	15	260	343	42.5	183	279	131	80	0.5	38h6
FM7-D150-S1D0-E03	556	265	230h7	250	25	300	476	80	420	271	205	15	260	343	42.5	183	279	131	80	0.5	38h6
FM7-D185-S1D0-E03	618	265	230h7	250	25	300	538	80	482	333	205	15	260	343	42.5	183	279	131	80	0.5	38h6
FM7-D220-S1D0-E03	656	265	230h7	250	25	300	576	80	520	371	205	15	260	343	42.5	183	279	131	80	0.5	38h6

Units in inches	L	LA	LB	LC	LG	LH	LL	LR	LD	LE	LF	Z	D	I	KD	KL	KI	KE	Q	QR	S
FM7-D055-S1D0-E03	18.7	8.4	7.1h7	8.0	0.7	9.8	16.3	2.3	13.8	8.8	6.7	0.5	8.0	10.6	1.6	6.2	8.0	4.4	2.36	0.02	1.1h6
FM7-D075-S1D0-E03	19.9	8.4	7.1h7	8.0	0.7	9.8	17.5	2.3	15.7	10.0	7.4	0.5	8.0	10.6	1.6	6.4	9.8	4.4	2.36	0.02	1.1h6
FM7-D110-S1D0-E03	21.9	10.4	9.1h7	9.8	0.9	11.8	18.7	3.1	16.5	10.6	8.0	0.5	10.2	13.5	1.6	7.2	10.9	5.1	3.15	0.02	1.5h6
FM7-D150-S1D0-E03	21.9	10.4	9.1h7	9.8	0.9	11.8	18.7	3.1	16.5	10.6	8.0	0.5	10.2	13.5	1.6	7.2	10.9	5.1	3.15	0.02	1.5h6
FM7-D185-S1D0-E03	24.3	10.4	9.1h7	9.8	0.9	11.8	21.1	3.1	18.9	13.1	8.0	0.5	10.2	13.5	1.6	7.2	10.9	5.1	3.15	0.02	1.5h6
FM7-D220-S1D0-E03	25.8	10.4	9.1h7	9.8	0.9	11.8	22.6	3.1	20.4	14.6	8.0	0.5	10.2	13.5	1.6	7.2	10.9	5.1	3.15	0.02	1.5h6

FM7. HS3 series. Flange mounting

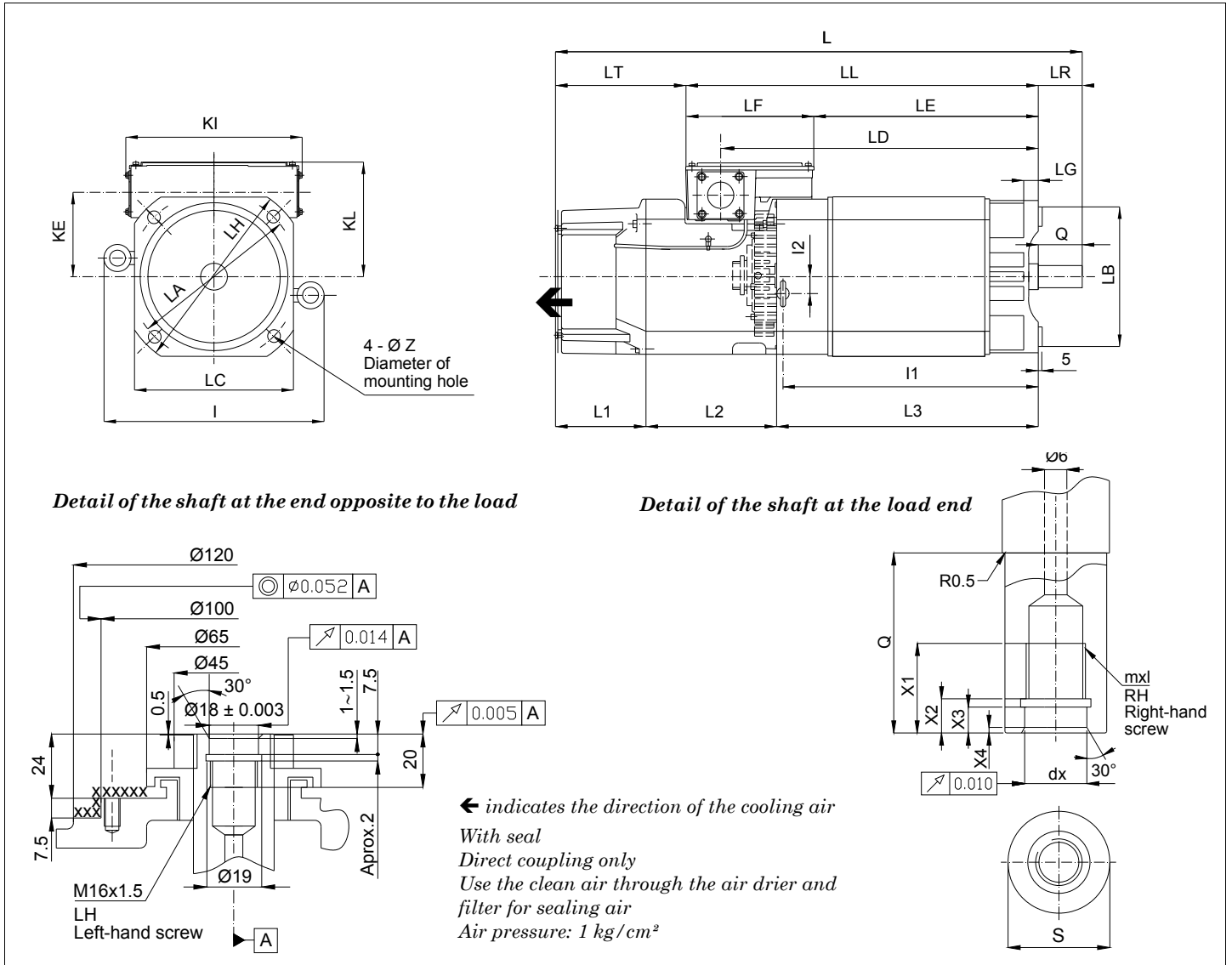

Units in mm	L	LA	LB	LC	LG	LH	LL	LR	LD	LE	LF	Z	D	I	KD	KL	KI	KE
FM7-D075-S1D0-HS3	715	215	180h7	204	20	250	446	60	401	256	190	15	204	271	42.5	158	250	114
FM7-D110-S1D0-HS3	751	265	230h7	250	25	300	476	70	420	271	205	15	260	343	42.5	183	279	131
FM7-D185-S1D0-HS3	813	265	230h7	250	25	300	538	70	482	333	205	15	260	343	42.5	183	279	131
FM7-D220-S1D0-HS3	851	265	230h7	250	25	300	576	70	520	371	205	15	260	343	42.5	183	279	131

Units in inches	L	LA	LB	LC	LG	LH	LL	LR	LD	LE	LF	Z	D	I	KD	KL	KI	KE
FM7-D075-S1D0-HS3	28.1	8.4	7.1h7	8.0	0.7	9.8	17.5	2.3	15.7	10.0	7.4	0.5	8.0	10.6	1.6	6.2	9.8	4.4
FM7-D110-S1D0-HS3	29.5	10.4	9.1h7	9.8	0.9	11.8	18.7	2.7	16.5	10.6	8.0	0.5	10.2	13.5	1.6	7.2	10.9	5.1
FM7-D185-S1D0-HS3	32.0	10.4	9.1h7	9.8	0.9	11.8	21.1	2.7	18.9	13.1	8.0	0.5	10.2	13.5	1.6	7.2	10.9	5.1
FM7-D220-S1D0-HS3	33.5	10.4	9.1h7	9.8	0.9	11.8	22.6	2.7	20.4	14.6	8.0	0.5	10.2	13.5	1.6	7.2	10.9	5.1

Units in mm	L1	L2	L3	I1	I2	Q	mxl	S	X1	X2	X3	X4	dx
FM7-D075-S1D0-HS3	137	210	308	288	33	60	M12 x1.25	28h6	31	14.5	13	1.0	16
FM7-D110-S1D0-HS3	142	208	331	320	30	70	M16 x1.50	38h6	38	17.0	15	1.0-1.5	20
FM7-D185-S1D0-HS3	142	208	393	382	30	70	M16 x1.50	38h6	38	17.0	15	1.0-1.5	20
FM7-D220-S1D0-HS3	142	208	431	420	30	70	M16 x1.50	38h6	38	17.0	15	1.0-1.5	20

Units in inches	L1	L2	L3	I1	I2	Q	mxl	S	X1	X2	X3	X4	dx
FM7-D075-S1D0-HS3	5.39	8.26	12.12	11.33	1.30	2.36	M12 x0.04	1.10h6	1.22	0.57	0.51	0.03	0.63
FM7-D110-S1D0-HS3	5.59	8.18	13.03	12.59	1.18	2.75	M16 x0.05	1.49h6	1.49	0.66	0.59	0.03-0.05	0.78
FM7-D185-S1D0-HS3	5.59	8.18	15.47	15.03	1.18	2.75	M16 x0.05	1.49h6	1.49	0.66	0.59	0.03-0.05	0.78
FM7-D220-S1D0-HS3	5.59	8.18	16.96	16.53	1.18	2.75	M16 x0.05	1.49h6	1.49	0.66	0.59	0.03-0.05	0.78

ASSEMBLING PRECISION

Associate the accuracies of the elements with the code assigned according to the table in order to interpret later data.

Code	Measurement
A	Parallelism of shaft extension
B	Rotational excentricity of shaft extension (runout)
C	Shaft runout at the end
D	Concentricity between flange and shaft diameters
E	Concentricity of the support side of the flange with respect to the machine axis
F	Perpendicularity of the support side of the flange with respect to the foot

FM7. E01/E02 series. Foot mounting

Units in mm	A	B		
FM7-A037-□3□□-E0□	0.03	0.02		
FM7-A055-□3□□-E0□	0.03	0.02		
FM7-A075-□3□□-E0□	0.033	0.022		
FM7-A090-□3□□-E0□	0.033	0.022		
FM7-A110-□3□□-E01	0.033	0.022		
FM7-A150-□3□□-E0□	0.033	0.022		
FM7-A185-□3□□-E0□	0.033	0.022		
FM7-A220-□3□□-E0□	0.033	0.022		
FM7-A300-□3□□-E01	0.042	0.028		
FM7-A370-□3□□-E01	0.042	0.028		
FM7-A510-□3□□-E0□	0.042	0.028		
FM7-B120-□3□□-E0□	0.033	0.022		
FM7-B170-□3□□-E0□	0.033	0.022		
FM7-B220-□3□□-E01	0.042	0.028		
FM7-B280-□3□□-E01	0.042	0.028		
FM7-C215-□3□□-E0□	0.042	0.028		
FM7-C270-□3□□-E0□	0.042	0.028		
FM7-E600-C3B□-E01	0.042	0.028		

FM7. E01/E02 series. Flange mounting

Units in mm	C	D	E	
FM7-A037-□1□□-E0□	0.020	0.040	0.040	
FM7-A055-□1□□-E0□	0.020	0.040	0.040	
FM7-A075-□1□□-E0□	0.022	0.040	0.040	
FM7-A090-□1□□-E0□	0.022	0.040	0.040	
FM7-A110-□1□□-E0□	0.022	0.046	0.040	
FM7-A150-□1□□-E0□	0.022	0.046	0.040	
FM7-A185-□1□□-E0□	0.022	0.046	0.040	
FM7-A220-□1□□-E0□	0.022	0.046	0.040	
FM7-A300-□1□□-E01	0.028	0.048	0.060	
FM7-A370-□1□□-E01	0.028	0.048	0.060	
FM7-A510-□1□□-E0□	0.028	0.070	0.072	
FM7-B120-□1□□-E0□	0.022	0.046	0.040	
FM7-B170-□1□□-E0□	0.022	0.046	0.040	
FM7-B220-□1□□-E01	0.028	0.048	0.060	
FM7-B280-□1□□-E01	0.028	0.048	0.060	
FM7-C215-□1□□-E0□	0.028	0.070	0.072	
FM7-C270-□1□□-E0□	0.028	0.070	0.072	
FM7-E600-C1B□-E01	0.028	0.070	0.072	

FM7. E01/E02 series. Flange and foot mounting

Units in mm	A	C	D	E	F
FM7-A110-□5□□-E01	0.033	0.022	0.046	0.04	0.130
FM7-A150-□5□□-E0□	0.033	0.022	0.046	0.04	0.130
FM7-A185-□5□□-E0□	0.033	0.022	0.046	0.04	0.130
FM7-A220-□5□□-E0□	0.033	0.022	0.046	0.04	0.130
FM7-A300-□5□□-E01	0.042	0.028	0.048	0.06	0.176
FM7-A370-□5□□-E01	0.042	0.028	0.048	0.06	0.176
FM7-A510-□5□□-E0□	0.042	0.028	0.048	0.06	0.176
FM7-B120-□5□□-E0□	0.033	0.022	0.046	0.04	0.130
FM7-B170-□5□□-E0□	0.033	0.022	0.046	0.04	0.130
FM7-B220-□5□□-E01	0.042	0.028	0.048	0.06	0.176
FM7-B280-□5□□-E01	0.042	0.028	0.048	0.06	0.176

Units in mm	A	C	D	E	F
FM7-C215-□5□□-E0□	0.042	0.028	0.048	0.06	0.176
FM7-C270-□5□□-E0□	0.042	0.028	0.048	0.06	0.176
FM7-E600-C5B□-E01	0.042	0.028	0.070	0.072	0.207

FM7. E03 series. Flange mounting

Units in mm	C	D	E	
FM7-D055-S1D0-E03	0.020	0.040	0.04	
FM7-D075-S1D0-E03	0.022	0.040	0.04	
FM7-D110-S1D0-E03	0.022	0.046	0.04	
FM7-D150-S1D0-E03	0.022	0.046	0.04	
FM7-D185-S1D0-E03	0.022	0.046	0.04	
FM7-D220-S1D0-E03	0.022	0.046	0.04	

FM7. HS3 series. Flange mounting

Units in mm	C	D	E	
FM7-D075-S1D0-HS3	0.022	0.040	0.04	
FM7-D110-S1D0-HS3	0.022	0.046	0.04	
FM7-D150-S1D0-HS3	0.022	0.046	0.04	
FM7-D220-S1D0-HS3	0.022	0.046	0.04	

BRAKE CHARACTERISTICS

FM7 motors do not offer the brake in any of their models.

FAN CHARACTERISTICS

All FM7 series spindle AC motors have an electrical cooling fan that generates a constant air flow regardless of the motor turning direction. This assures proper motor cooling in all duty cycles. This fan starts turning when connected to the three-phase line.

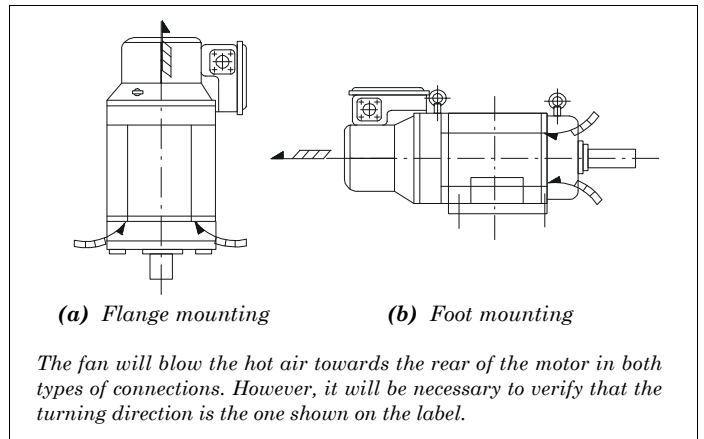

MANDATORY. Make sure that the fan is turning in the direction indicated on the label that is located on the outside of the body and that the air flowing as shown in the drawing below.

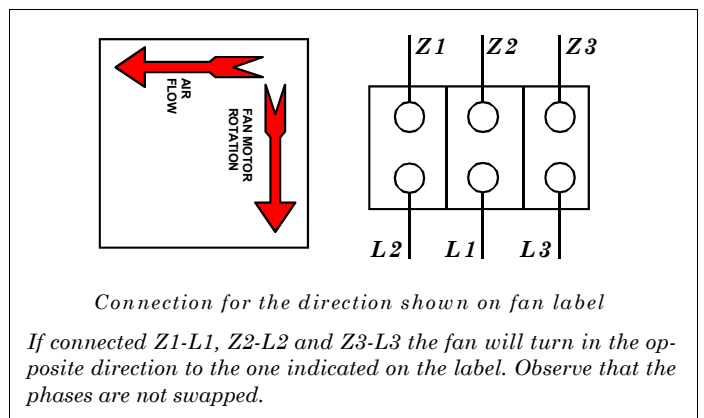

The fan connection to the three/phase line is done through 4/wire cable with a minimum section of 1.5 mm² per wire.

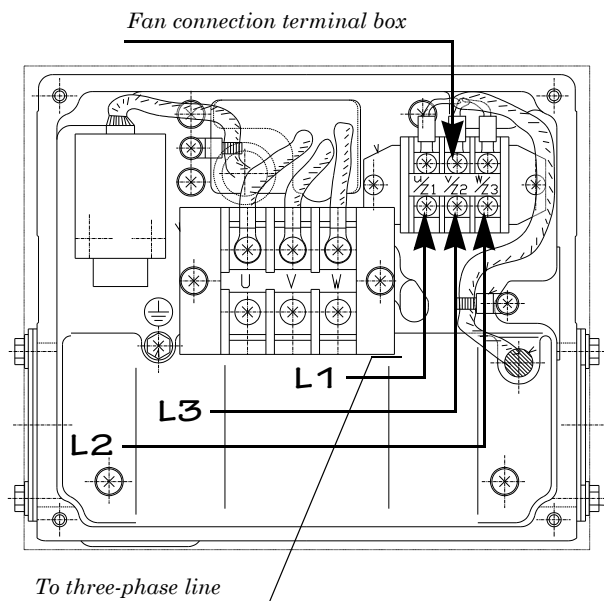

Note that phases L1 and L2 are swapped for proper air flow and motor turning directions indicated on the outside label.

Electrical characteristics

Motor	Voltage	Frequency	Power	Current
Units	V AC	Hz	W	Arms
FM7-A037-□□□□-E0□	400 460	50/60 60	37/51 60	0.11/0.14 0.16
FM7-A055-□□□□-E0□ FM7-D055-S1D0-E03	400 460	50/60 60	64/85 96	0.11/0.16 0.17
FM7-A075-□□□□-E0□ FM7-D075-S1D0-E03 FM7-D075-S1D0-HS3	400 460	50/60 60	41/62 63	0.07/0.10 0.09
FM7-A090-□□□□-E0□	400 460	50/60 60	45/58 63	0.11/0.10 0.10
FM7-A110-□□□□-E0□ FM7-D110-S1D0-E03 FM7-D110-S1D0-HS3	400 460	50/60 60	59/83 88	0.11/0.14 0.13
FM7-A150-□□□□-E0□ FM7-D150-S1D0-E03	400 460	50/60 60	59/83 88	0.11/0.14 0.13
FM7-A185-□□□□-E0□ FM7-D185-S1D0-E03 FM7-D185-S1D0-HS3	400 460	50/60 60	59/83 88	0.11/0.14 0.13
FM7-A220-□□□□-E0□ FM7-D220-S1D0-E03 FM7-D220-S1D0-HS3	400 460	50/60 60	57/82 87	0.11/0.13 0.13
FM7-A300-□□□□-E0□	400 460	50/60 60	152/205 226	0.38/0.38 0.40
FM7-A370-□□□□-E0□	400 460	50/60 60	152/205 226	0.38/0.38 0.40
FM7-A510-□□□□-E0□	400 460	50/60 60	86/117 128	0.22/0.23 0.24
FM7-B120-□□□□-E0□	400 460	50/60 60	58/82 88	0.11/0.14 0.13
FM7-B170-□□□□-E0□	400 460	50/60 60	57/82 87	0.11/0.13 0.13
FM7-B220-□□□□-E0□	400 460	50/60 60	163/218 238	0.39/0.39 0.41
FM7-B280-□□□□-E0□	400 460	50/60 60	152/205 226	0.38/0.38 0.40
FM7-C215-□□□□-E0□	400 460	50/60 60	86/117 128	0.22/0.23 0.24
FM7-C270-□□□□-E0□	400 460	50/60 60	103/140 159	0.18/0.23 0.22
FM7-E600-C□B□-E01	400 460	50/60 60	94/132 143	0.22/0.25 0.25

PRECAUTIONS WHEN INSTALLING THE MOTOR

This section describes the environmental precautions to bear in mind when installing the motor.



MANDATORY. The flange and the shaft of the motor have an anticorrosive layer of paint or grease. The flange, the shaft and the key must be cleaned before installing the motor.

The motor must be installed under the following conditions:

- ❑ Leave enough clearance for the cooling fan to blow the air out. The minimum clearance between the machine and the exit of the motor fan is 100 mm (3.94 in).
- ❑ Install the motor in a clean place, away from oil and water. If there is a chance that the motor may be exposed to oil or water, cover it for protection. If dirty oil or water gets into the motor, it would decrease the isolation resistance and cause a grounding failure.
- ❑ Make sure that the motor is firmly secured to the floor or with the flange because the weight of the motor the dynamic load when it is running may generate vibrations.
- ❑ Install the motor in an environment free of dust and metal particles. The motor has an integrated fan with an internal structure that provides cooling air to the motor. Blocking the air flow with dust other strange elements may decrease the efficiency of the cooling system.

CONSIDERATIONS FOR MOTOR INSTALLATION

Bear in mind the following considerations when installing the motor:

- ❑ If it is a **flange-mounted motor**, it may be installed with its shaft at the load end and at an angle between the horizontal and vertical with the shaft facing down.

Note. The motor must not be mounted with its shaft facing up.

- ❑ If it is a **foot-mounted motor**, it must be mounted with its feet secured to the floor. If the motor is installed vertically, its shaft must be facing down.

Note. The motor must not be mounted with its shaft facing up.

CAUTION!



Note that when installing transmission pulleys or gearboxes, any blow to the shaft reduces its useful life, of bearings, and may damage the encoder.

Therefore, do not hit it for any reason.

RADIAL LOADS

A misalignment between the motor shaft and the machine axis increases vibration of the shaft and shortens the life of the ball bearings and couplings. Likewise, exceeding certain maximum radial load values may cause a similar effect of the ball bearings.

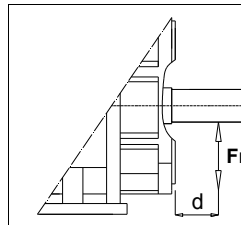

In order to avoid these problems, the maximum values given in the table for radial load must not be exceeded.

They are assumed to be applied at the end of the shaft and for the maximum motor speed.

FM7. E01/E02 series

Motor	Radial force ·Fr·		Distance ·d·	
	N	lb	mm	in
Units				
FM7-A037-□□□□-E01	1370	308.0	60	2.36
FM7-A037-□□□□-E02	1140	256.3	60	2.36
FM7-A055-□□□□-E01	1570	353.0	80	3.15
FM7-A055-□□□□-E02	1510	339.5	80	3.15
FM7-A075-□□□□-E01	1570	353.0	110	4.33
FM7-A075-□□□□-E02	1510	339.5	110	4.33

FM7. E01/E02 series

Motor	Radial force ·Fr·		Distance ·d·	
	N	lb	mm	in
Units				
FM7-A090-□□□□-E01	1570	353.0	110	4.33
FM7-A090-□□□□-E02	1470	330.5	110	4.33
FM7-A110-□□□□-E01	1715	385.5	110	4.33
FM7-A110-□□□□-E02	1590	357.4	110	4.33
FM7-A150-□□□□-E01	2640	593.5	110	4.33
FM7-A150-□□□□-E02	1715	385.5	110	4.33
FM7-A185-□□□□-E01	2640	593.5	110	4.33
FM7-A185-□□□□-E02	1715	385.5	110	4.33
FM7-A220-□□□□-E01	2640	593.5	110	4.33
FM7-A220-□□□□-E02	1715	385.5	110	4.33
FM7-A300-□□□□-E01	3920	881.3	140	5.51
FM7-A370-□□□□-E01	3920	881.3	140	5.51
FM7-A510-□□□□-E01	4900	1102.0	140	5.51
FM7-A510-□□□□-E02	4500	1012.0	140	5.51
FM7-B120-□□□□-E01	2640	593.5	110	4.33
FM7-B120-□□□□-E02	1715	385.5	110	4.33
FM7-B170-□□□□-E01	2640	593.5	110	4.33
FM7-B170-□□□□-E02	1715	385.5	110	4.33
FM7-B220-□□□□-E01	3920	881.3	140	5.51
FM7-B280-□□□□-E01	3920	881.3	140	5.51
FM7-C215-□□□□-E01	4900	1102.0	140	5.51
FM7-C215-□□□□-E02	4500	1012.0	140	5.51
FM7-C270-□□□□-E01	4900	1102.0	140	5.51
FM7-C270-□□□□-E02	4500	1012.0	140	5.51
FM7-E600-C□B□-E01	8820	1982.8	140	5.51

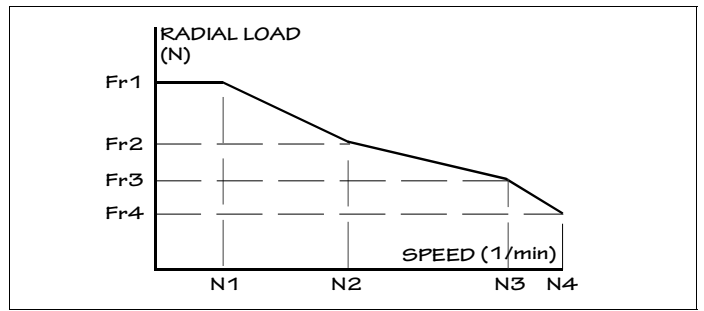

Motor	Radial force · Fri ·				Speed · Ni ·			
	N				rev/min			
Units	Fr1	Fr2	Fr3	Fr4	N1	N2	N3	N4*
FM7-A037-□□□□-E0□	1610	1467	1370	1140	5630	7190	9000	12000
FM7-A055-□□□□-E0□	1910	1890	1570	1510	4880	5000	9000	10000
FM7-D055-S1D0-□□3	1910	1890	1570	196	4880	5000	9000	15000
FM7-A075-□□□□-E0□	1990	1890	1570	1510	4310	5965	9000	10000
FM7-D075-S1D0-□□3	1990	1890	1570	196	4310	5965	9000	15000
FM7-A090-□□□□-E0□	1990	1890	1570	1470	4610	5625	9000	10000
FM7-A110-□□□□-E0□	2810	2150	1715	590	1500	4560	9000	10000
FM7-D110-S1D0-□□3	2810	2150	1715	290	1500	4560	9000	12000
FM7-A150-□□□□-E0□	3230	3195	2640	1715	4360	4560	8000	9000
FM7-D150-S1D0-□□3	3230	3195	2640	290	4360	4560	8000	12000
FM7-A185-□□□□-E0□	3880	3000	2640	1715	2340	5265	8000	9000
FM7-D185-S1D0-□□3	3880	3000	2640	290	2340	5265	8000	12000
FM7-A220-□□□□-E0□	3930	2935	2640	1715	1500	6140	8000	9000
FM7-D220-S1D0-□□3	3930	2935	2640	290	1500	6140	8000	12000
FM7-A300-□□□□-E01	5570	4175	3920	-	1500	5440	6500	-
FM7-A370-□□□□-E01	5720	4435	3920	-	1640	4385	6500	-
FM7-A510-□□□□-E0□	5720	5390	4900	4500	2960	3510	5000	6000
FM7-B120-□□□□-E0□	3530	3130	2640	1715	2990	5000	8000	9000
FM7-B170-□□□□-E0□	3530	3130	2640	1715	2990	5000	8000	9000
FM7-B220-□□□□-E01	5720	4610	3920	-	2080	3947	6500	-
FM7-B280-□□□□-E01	5720	4520	3920	-	2220	4210	6500	-
FM7-C215-□□□□-E0□	5720	5565	4900	4500	3340	3510	5000	6000
FM7-C270-□□□□-E0□	5720	5305	4900	4500	3600	3860	5000	6000

* The values of Fr4 and N4 do not apply to FM7-A□□□-□□□□-E01.

FM7. E03 series

Motor	Radial force ·Fr·		Distance ·d·	
	N	lb	mm	in
Units				
FM7-D055-S1D0-E03	196	44.1	60	2.36
FM7-D075-S1D0-E03	196	44.1	60	2.36
FM7-D110-S1D0-E03	290	65.2	80	3.15
FM7-D150-S1D0-E03	290	65.2	80	3.15
FM7-D185-S1D0-E03	290	65.2	80	3.15
FM7-D220-S1D0-E03	290	65.2	80	3.15

FM7. HS3 series

Motor	Radial force ·Fr·		Distance ·d·	
	N	lb	mm	in
Units				
FM7-D075-S1D0-E03	196	44.1	60	2.36
FM7-D110-S1D0-E03	290	65.2	70	2.75
FM7-D185-S1D0-E03	290	65.2	70	2.75
FM7-D220-S1D0-E03	290	65.2	70	2.75

RADIAL LOAD GRAPHS-RPM

When using mechanical transmission elements, the end of the motor shaft may be subject to radial loads.

- Make sure that the maximum radial load values at the end of the shaft do not exceed the permitted values shown on the graphs depending on the rev/min of the shaft.
- Exceeding these radial load values increases the vibration of the shaft and shortens the life of the ball bearings and couplings.

The particular graph may be used to determine the permitted radial loads that may be applied on to the end of the motor shaft depending on its rev/min.

BALL BEARINGS. USEFUL LIFE

Note. The useful life of the bearings is approximately 12000 hours of continuous operation at max. speed both for version E01 and E02.

MOUNTING METHODS KEY

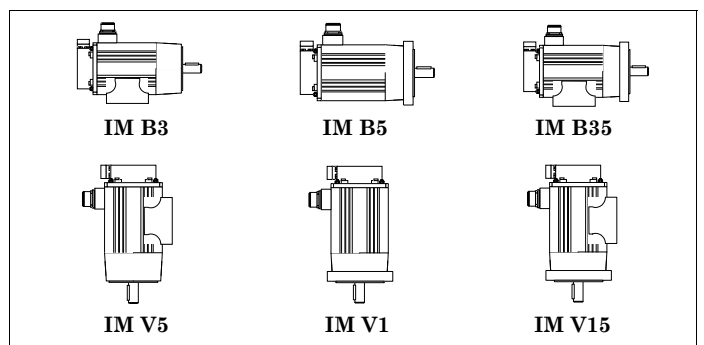

SALES MODEL

The sales model is stored in the motor encoder. The drive software can automatically adjust the motor parameters by reading that "sales model" from the encoder memory.

MOTOR MODEL NOMENCLATURE

FM7. E01/E02 series

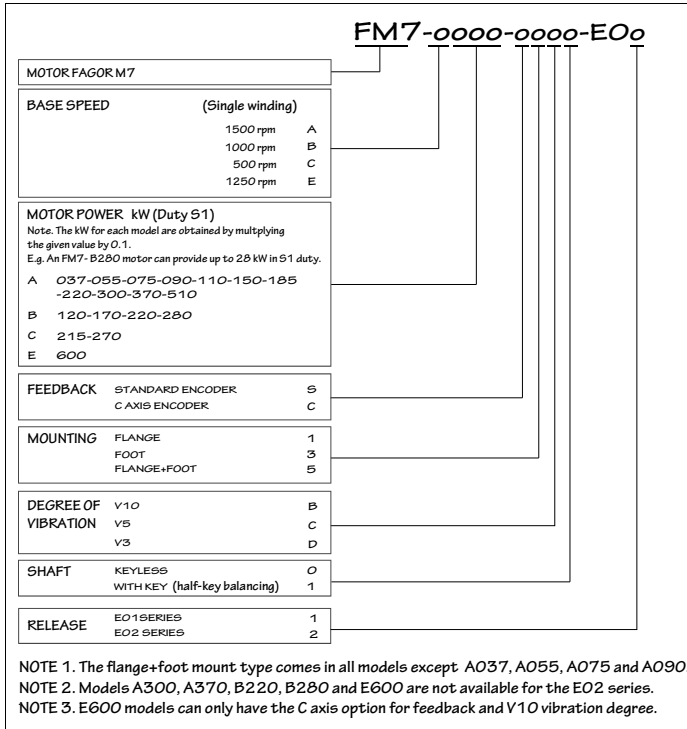

FM7. E03/HS3 series

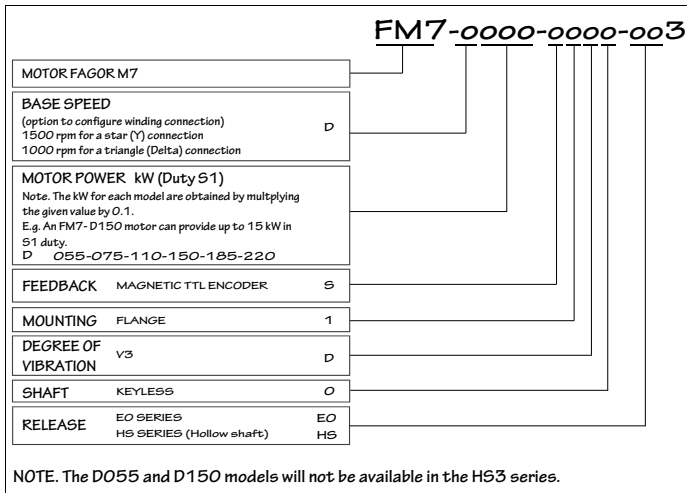

RATING PLATE DATA

The specifications label stuck on FM7 servo motors supplied by Fagor Automation S. Coop. offers the necessary data to identify the motor for the user.

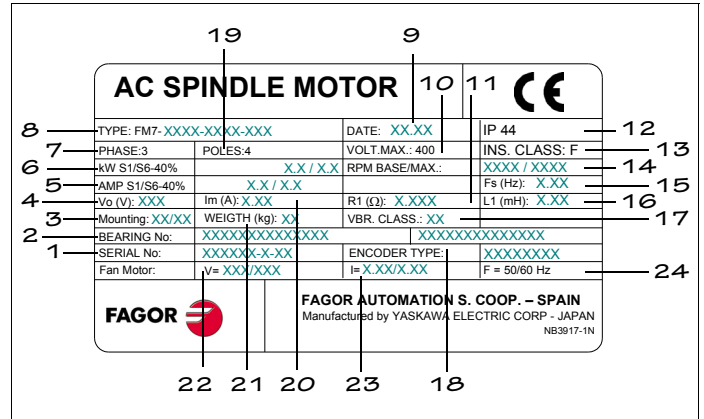

1	Serial number
2	Bearing number: LOAD side / FAN side
3	Mounting type
4	Voltage without load
5	Rated current in S1/S6-40%
6	Rated power in S1/S6-40%
7	Nr of phases
8	Motor model reference
9	Manufacturing year/month
10	Maximum voltage
11	Stator winding resistance per phase
12	Protection degree
13	Insulation class
14	Base speed / maximum speed
15	Slip frequency
16	Stator dispersion inductance per phase
17	Level of vibration
18	Encoder type
19	Nr of poles
20	Magnetizing current
21	Mass
22	Fan supply voltage at 50/60 Hz
23	Fan supply current at 50/60 Hz
24	Frequency of the fan supply voltage

FM9 MOTORS

GENERAL CHARACTERISTICS

These motors have been manufactured in accordance with the European regulations EN 60204-1 and EN 60034 as instructed by the European Directive 2006/95/EC on Low Voltage (LVD).

Motor type	Induction. Squirrel cage
Thermal protection	Thermistor KTY84-130
Degree of vibration	V5 (standard)
Type of construction	Horizontal: IM B3, IM B5, IM B35. Vertical: IM V1, IM V5, IM V15, IM V3, IM V6, IM V36.
Electric winding insulation	Class F (155°C/311°F)
Degree of protection	IP 54
Storage temperature	-10°C/60°C (14°F/140°F)
Ambient temperature allowed	-15°C/40°C (5°F/104°F)
Working ambient humidity	80 % max. (non condensing)
Max. recommended altitude	1000 m (3281 ft) max. over sea level
Fan voltage	230/400 V AC (Δ/Y) (3-phase) - 50 Hz. 460 V AC (Y) (3-phase) - 60 Hz. Independent voltage supply.
Withstanding of the isolation voltage	1200 V AC
Insulation resistance	30 M Ω
Feedback	"C" axis 1024 ppt sinusoidal SinCos Stegmann
Conformity standard	IEC 34-1

The "F" classification of the winding isolation is based on its maximum running temperature capability.

This temperature is 155°C (311°F) and represents the maximum operating temperature for the winding. At this temperature, if the motor were running in a clean and dry environment for up to 40 hours a week, it would have a life expectancy of 10 to 20 years before the isolation would get damaged due to heat and would no longer withstand the applied voltage.

TEMPERATURE SENSOR

The temperature sensor is a KTY84-130 thermistor used as thermal protection of the motor and it is located in the stator winding. It has a positive temperature coefficient (PTC) and they should be used in control and measurement systems within a range between -40°C (-40°F) and 300°C (572°F).

Sensor type	KTY84-130
Resistance at 20°C (68°F)	581 Ω
Resistance at 100°C (212°F)	1000 Ω
Sensor connection	Feedback cable

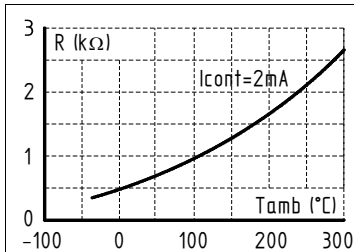

The following figure shows the graph of the resistance variation of the sensor as a function of the ambient temperature (average values). The wires of the temperature sensor are included in the feedback cable.



WARNING. The temperature sensor KTY84-130 has polarity. If you wish to manufacture your own feedback cable, make sure that the polarity is correct when soldering these two wires to the corresponding pins of the connector.

Only temperature sensors that meet the safety specifications given by regulation EN 61800-5-1 may be connected to pins 21 (temp) and 22 (temp) of drive connector X4. Ignoring this warning may cause risk of electrical shock and/or damage to the unit.

OUTSIDE APPARENCE

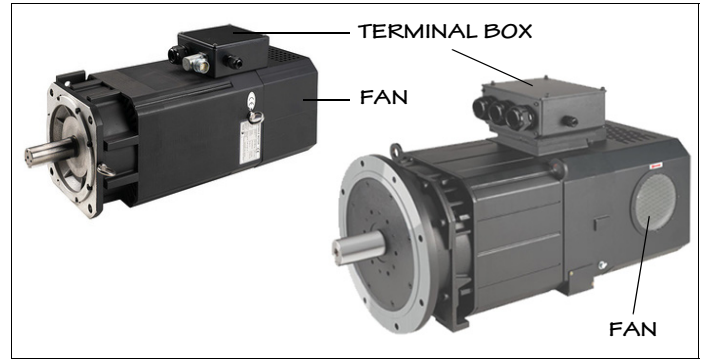

TERMINAL BOX. LAYOUT OF THE CONNECTION TERMINAL

The layout of the terminals in the box on top of the motor depends on the type of motor. The upper image shows the terminal box for the FM9-B037-C5C□-E01 and FM9-B055-C5C□-E01-A model. The lower image shows the terminal box for the FM9-B071-C5C□-E01, FM9-A100-C5C□-E01, FM9-B113-C5C□-E01 and FM9-A130-C5C□-E01 models.

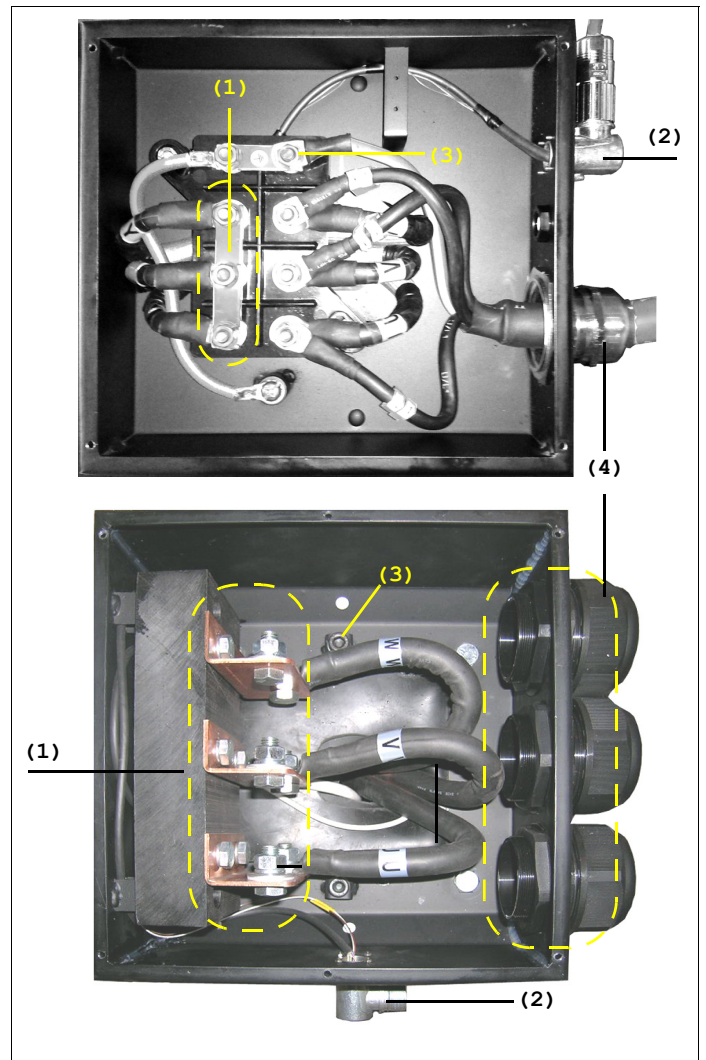

- | | |
|---|---|
| 1 | Terminals / plates for motor power connection |
| 2 | Connector for encoder connection |
| 3 | Ground bolt |
| 4 | Cable gland(s) of the power cable hose |

NOTE. Observe that the fan connecting terminals are in another smaller terminal box attached to the fan.

TECHNICAL DATA AND CHARACTERISTICS CURVES

E01 series

The following figures show the torque and power characteristics for motor version E01. Note that the models corresponding to this version E01 are: FM9-B037, FM9-B055, FM7-B071, FM7-A100, FM7-B113 and FM7-A130). Note that the value of weight B/P (flange/foot) indicated in the data table indicates the weight depending on whether it is a flange or foot mounted model. Their power and torque graphs are shown here for duty cycles S1 and S6-40 % (duty cycle of 10 minutes). The tables accompanying the graphs show the technical data for each model.

The AC motors of the FM9 series for main-spindle drives must be fanned all the time while running regardless of their duty cycles.

FM9-B037-C5C□-E01

Rated power	Rated speed	Rated torque	Rated current	Max. speed		Inertia	Mass B/P
				E01	-		
P _n (kW)	n _N (1/min)	M _n (N·m)	I _n (Arms)	n _{max} (1/min)	-	J (kg·cm ²)	P (kg)
37.0	1000	350.0	74.7	5000	-	3000	265

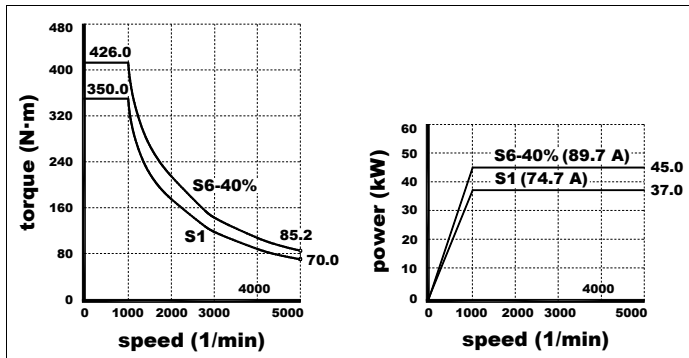

FM9-B055-C5C□-E01-A

Rated power	Rated speed	Rated torque	Rated current	Max. speed		Inertia	Mass B/P
				E01	-		
P _n (kW)	n _N (1/min)	M _n (N·m)	I _n (Arms)	n _{max} (1/min)	-	J (kg·cm ²)	P (kg)
55.0	1000	525.2	104.4	5000	-	6900	440

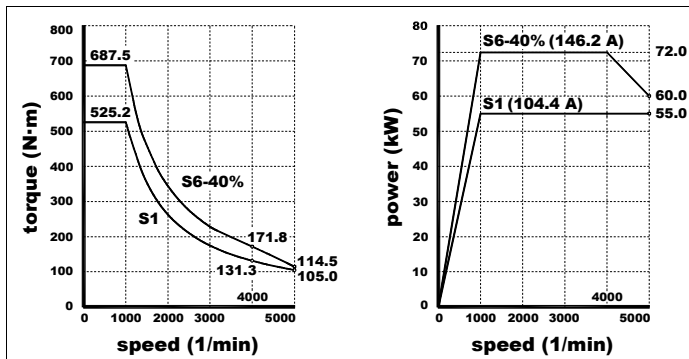

FM9-B071-C5C□-E01

Rated power	Rated speed	Rated torque	Rated current	Max. speed		Inertia	Mass B/P
				E01	-		
P _n (kW)	n _N (1/min)	M _n (N·m)	I _n (Arms)	n _{max} (1/min)	-	J (kg·cm ²)	P (kg)
71.0	1000	678.0	134.8	4500	-	14790	680

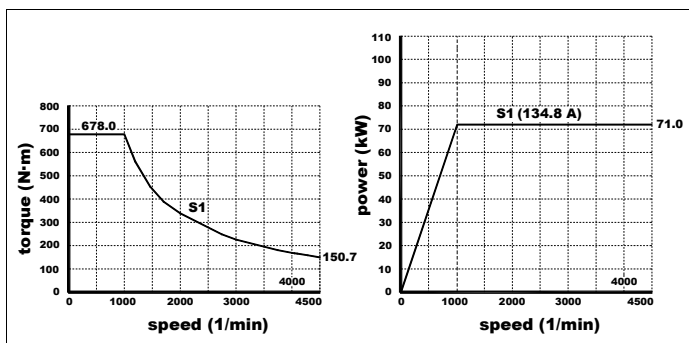

FM9-A100-C5C□-E01

Rated power	Rated speed	Rated torque	Rated current	Max. speed		Inertia	Mass B/P
				E01	-		
P _n (kW)	n _N (1/min)	M _n (N·m)	I _n (Arms)	n _{max} (1/min)	-	J (kg·cm ²)	P (kg)
100.0	1500	636.6	190.0	4500	-	14790	635

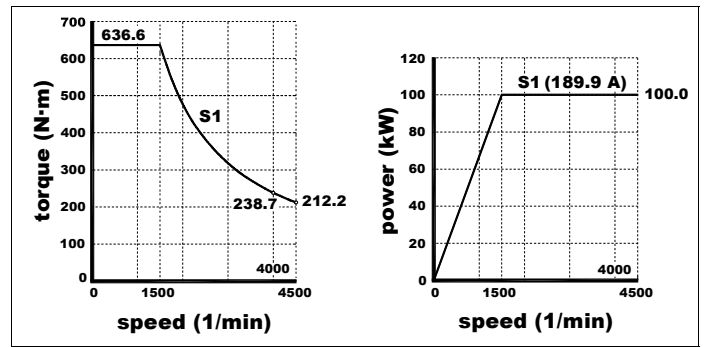

FM9-B113-C5C□-E01

Rated power	Rated speed	Rated torque	Rated current	Max. speed		Inertia	Mass B/P
				E01	-		
P _n (kW)	n _N (1/min)	M _n (N·m)	I _n (Arms)	n _{max} (1/min)	-	J (kg·cm ²)	P (kg)
113.0	1000	1079.0	215.0	4500	-	23260	860

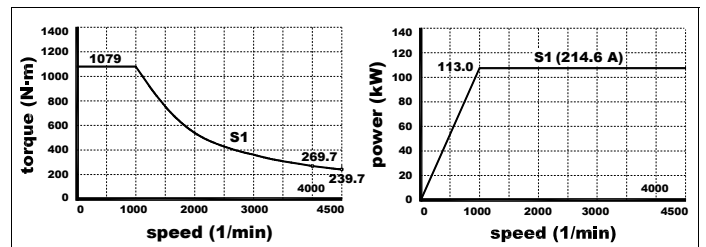

FM9-A130-C5C□-E01

Rated power	Rated speed	Rated torque	Rated current	Max. speed		Inertia	Mass B/P
				E01	-		
P _n (kW)	n _N (1/min)	M _n (N·m)	I _n (Arms)	n _{max} (1/min)	-	J (kg·cm ²)	P (kg)
130.0	1500	827.6	246.9	4500	-	19300	745

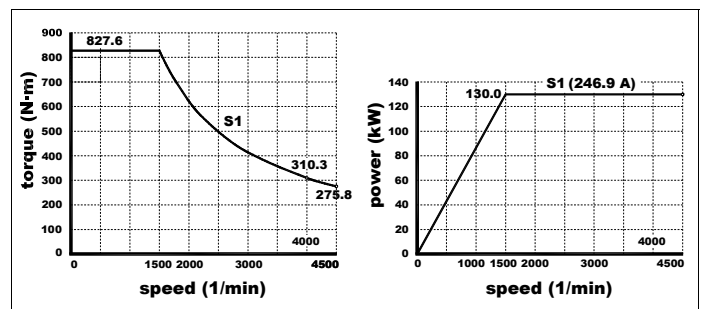

DIMENSIONS

Dimensions in mm. 1 in = 25.4 mm

C: Shaft height, PCD: Pitch Circle Diameter

FM9-B037-C5CX-E01

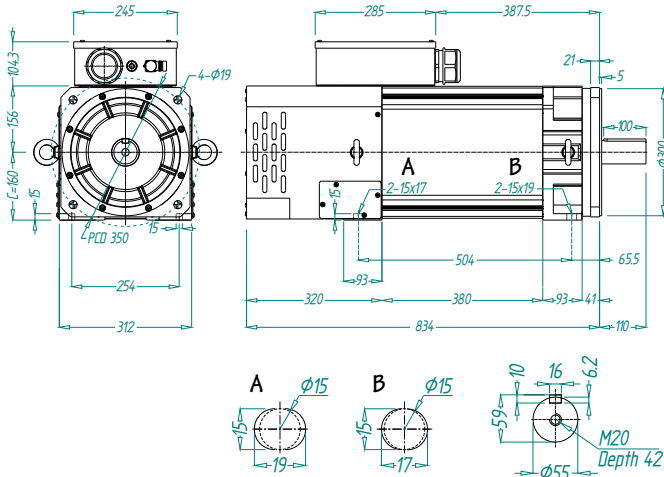

FM9-B055-C5CX-E01-A

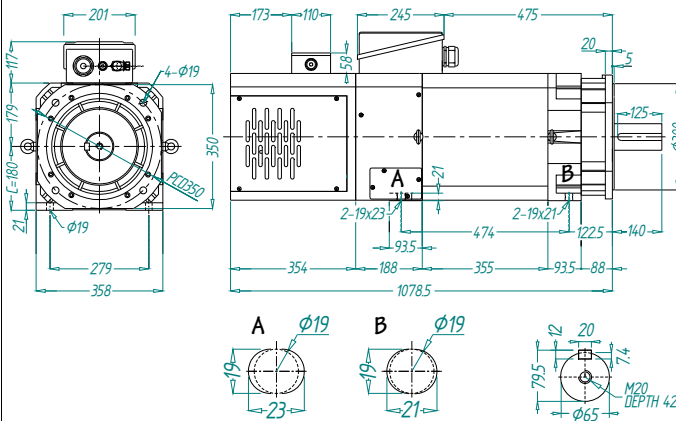

FM9-B071-C5CX-E01, FM9-A100-C5CX-E01, FM9-B113-C5CX-E01, FM9-A130-C5CX-E01

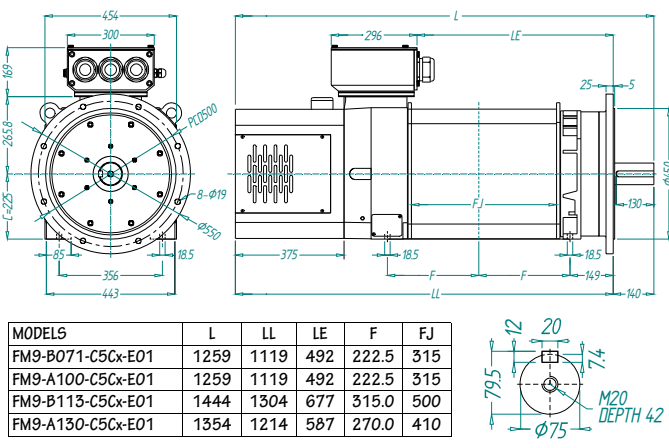

ASSEMBLING PRECISION

Associate the accuracies of the elements with the code assigned according to the table in order to interpret later data.

Code	Measurement
A	Runout of the shaft extension.
B	Concentricity of the fitting diameter between the flange and the shaft.
C	Concentricity of the support face of the flange with respect to the machine axis.
D	Perpendicularity of the support side of the flange with respect to the foot.

E01 series. Flange and foot mounting

Units in mm	A	B	C	D
FM9-B037-C5C□-E01	0.05	0.13	0.08	0.1
FM9-B055-C5C□-E01-A	0.05	0.13	0.08	0.1
FM9-B071-C5C□-E01	0.05	0.13	0.08	0.1
FM9-A100-C5C□-E01	0.05	0.13	0.08	0.1
FM9-B113-C5C□-E01	0.05	0.13	0.08	0.1
FM9-A130-C5C□-E01	0.05	0.13	0.08	0.1

BRAKE CHARACTERISTICS

FM9 motors do not offer the brake in any of their models.

FAN CHARACTERISTICS

All FM9 models spindle AC motors have an electrical cooling fan that generates a constant air flow regardless of the motor turning direction. This assures proper motor cooling in all duty cycles. This fan starts turning when connected to the mains.

FM9-B037-C5CX-E01

Fan connection terminals box

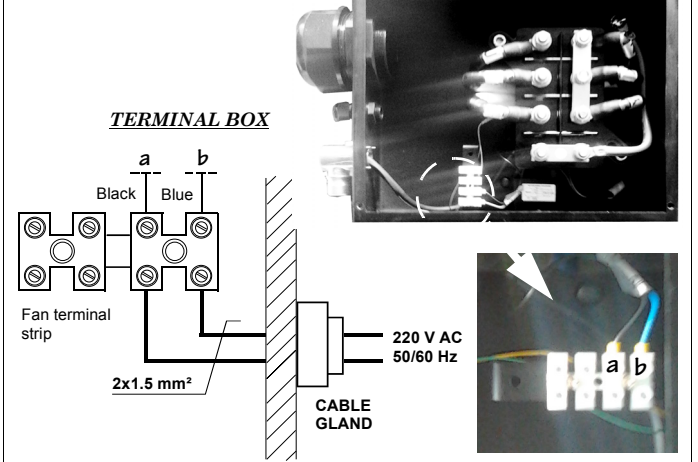

FM9-B055-C5CX-E01-A, FM9-B071-C5CX-E01, FM9-A100-C5CX-E01, FM9-B113-C5CX-E01, FM9-A130-C5CX-E01

Fan connection terminals box

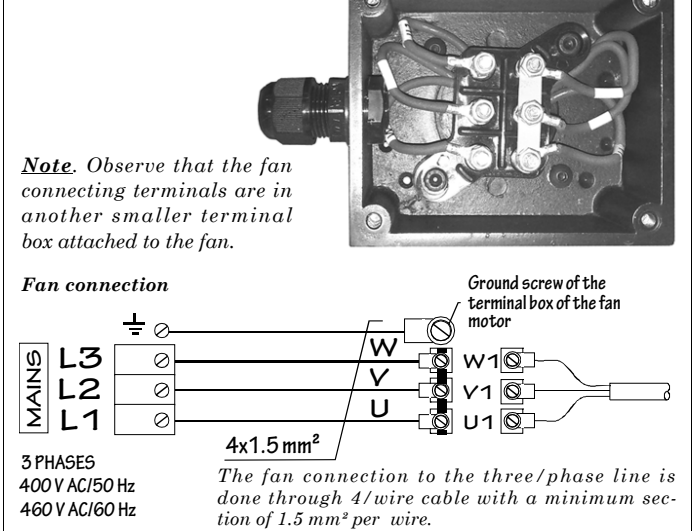

Electrical characteristics

Motor	Voltage V AC	Frequency Hz	Power W	Current Arms
FM9-B037-C5C□-E01	220 220	50 60	195 250	0.92 1.15
FM9-B□□□-C5C□-E01	400 460	50 60	1500 1750	3.25 3.20
FM9-A□□□-C5C□-E01	400 460	50 60	1500 1750	3.25 3.20

PRECAUTIONS WHEN INSTALLING THE MOTOR

This section describes the environmental precautions to bear in mind when installing the motor.



MANDATORY. The flange and the shaft of the motor have an anticorrosive layer of paint or grease. The flange, the shaft and the key must be cleaned before installing the motor.

The motor must be installed under the following conditions:

- ❑ Leave enough clearance for the cooling fan to blow the air out. The minimum clearance between the machine and the exit of the motor fan is 100 mm (3.94 in).
- ❑ Install the motor in a clean place, away from oil and water. If there is a chance that the motor may be exposed to oil or water, cover it for protection. If dirty oil or water gets into the motor, it would decrease the isolation resistance and cause a grounding failure.
- ❑ Make sure that the motor is firmly secured to the floor or with the flange because the weight of the motor the dynamic load when it is running may generate vibrations.
- ❑ Install the motor in an environment free of dust and metal particles. The motor has an integrated fan with an internal structure that provides cooling air to the motor. Blocking the air flow with dust other strange elements may decrease the efficiency of the cooling system.

CONSIDERATIONS FOR MOTOR INSTALLATION

CAUTION!



Note that when installing transmission pulleys or gearboxes, any blow to the shaft reduces its useful life, of bearings, and may damage the encoder.

Therefore, do not hit it for any reason.

BALL BEARINGS. USEFUL LIFE

The useful life of the bearings is approximately 5000 hours of continuous operation at max. speed. The references of the bearings located at the shaft end and at the fan end are indicated on the identifications plate stuck on one side of the motor.

SALES MODEL

The sales model is stored in the motor encoder. The drive software can automatically adjust the motor parameters by reading that "sales model" from the encoder memory.

MOTOR MODEL NOMENCLATURE

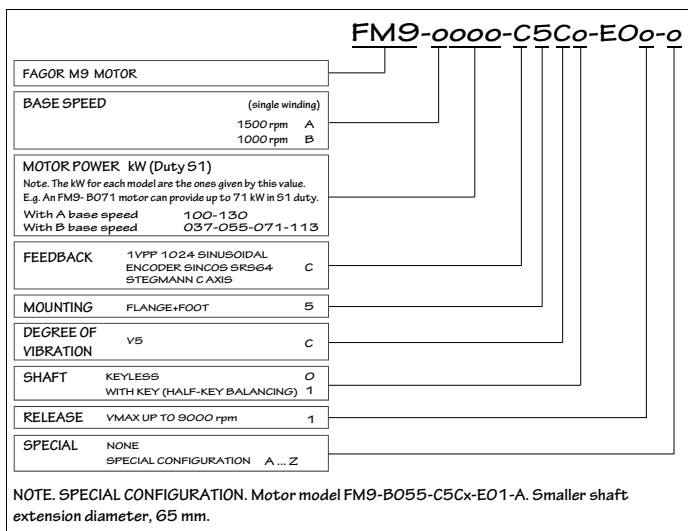

MOUNTING METHODS KEY

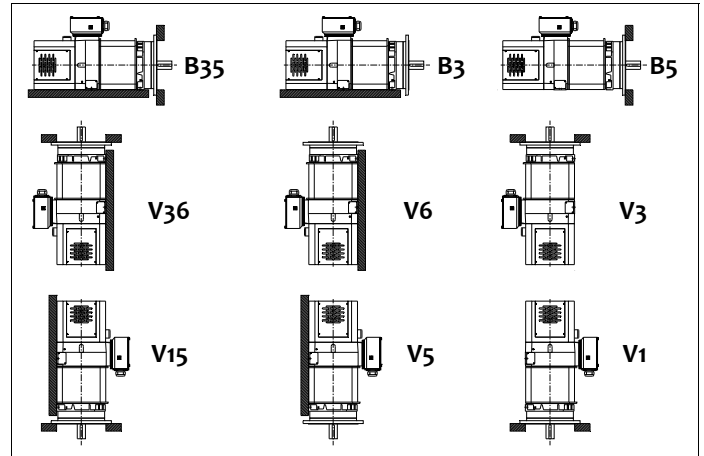

RATING PLATE DATA

The specifications label stuck on FM9 servo motors supplied by Fagor Automation S. Coop offers the necessary data to identify the motor for the user.

19 20 9 10			
AC SPINDLE MOTOR			
8	TYPE: FM9-XXXX-C5CX-EO1	DATE: XXXX.XX	IP 54
7	PHASE: 3	POLES: 4	VOLT. MAX.: 380
6	kW S1/S6-40%: X.X / X.X	RPM BASE/MAX.: XXXX / XXXX	INS. CLASS: F
5	AMPS S1/S6: X.X / X.X	Rs (Hz): X.X	
4	Vo (V): XXX	Im (A): X.XX	R1 (Ω): X.XXX
3	Mounting:		
2	B3/B5/V1/V5/V3/V6	WEIGHT (kg): XX	VBR. CLASS.: V5
1	BEARING No: XXXX / XXXX		ENCODER TYPE: 1024 PPR
FAGOR		FAGOR AUTOMATION S. COOP. - SPAIN	
21 11			

1	Serial number
2	Bearing number: LOAD side / FAN side
3	Mounting type
4	Voltage without load
5	Rated current in S1/S6-40%
6	Rated power in S1/S6-40%
7	Nr of phases
8	Motor model reference
9	Manufacturing year/month
10	Maximum voltage
11	Stator winding resistance per phase
12	Degree of protection
13	Insulation class
14	Base speed / maximum speed
15	Slip frequency
16	Stator dispersion inductance per phase
17	Level of vibration
18	Encoder type
19	Nr of poles
20	Magnetizing current
21	Mass

ELECTRONIC MODULES

POWER SUPPLY MODULE. PS

Module in charge converting the alternating current of mains into DC BUS voltage for the drives.

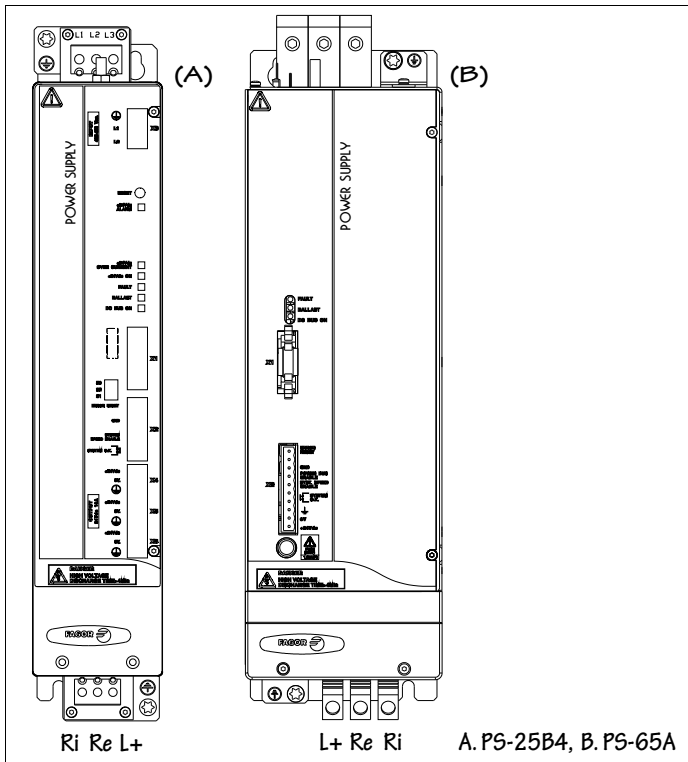

REGENERATIVE POWER SUPPLY. XPS

Module similar to the PS capable of returning energy to mains and offering a voltage supply of 24 V.

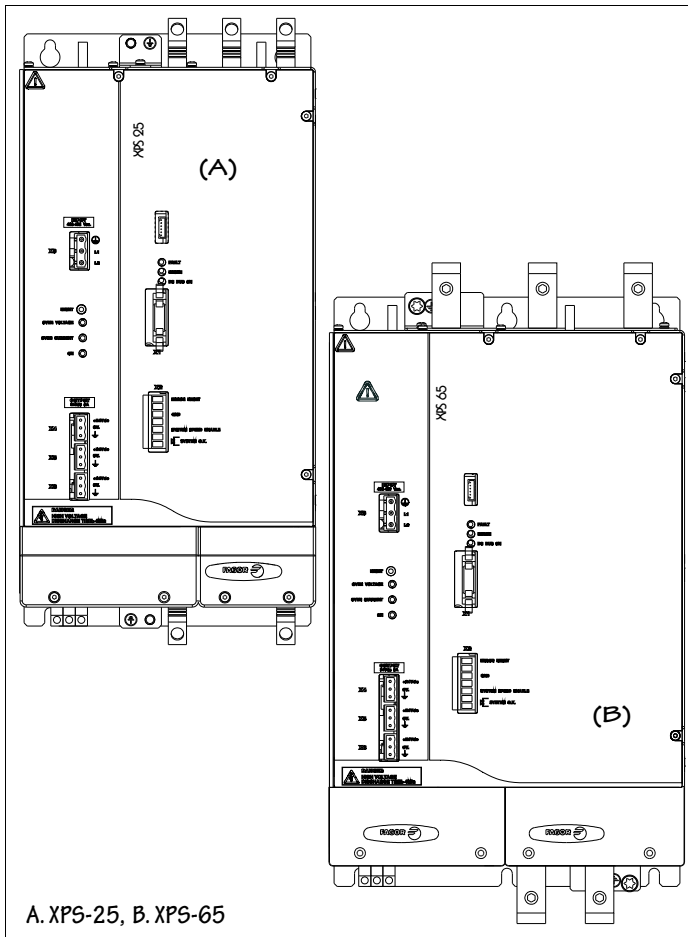

REGENERATIVE REGULATED POWER SUPPLIES. RPS

Modules similar to the XPS capable of returning energy to mains; they offer a 24 V power supply. The bus voltage is programmable and independent from the mains voltage.

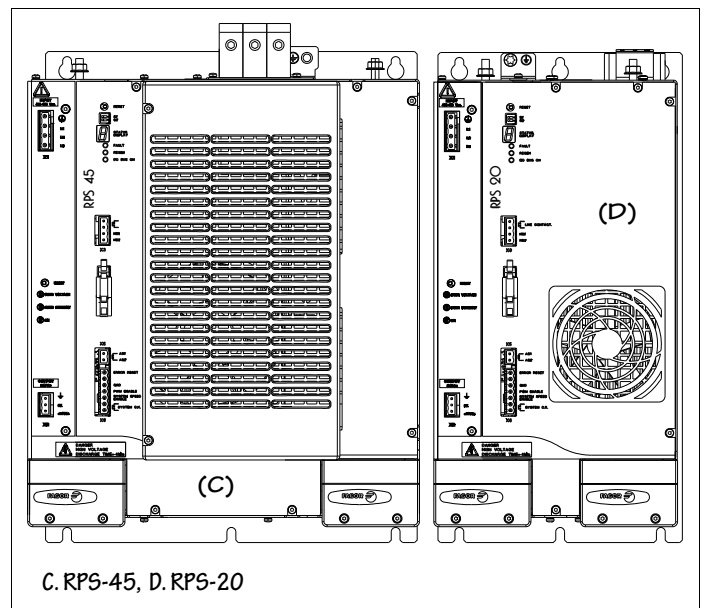
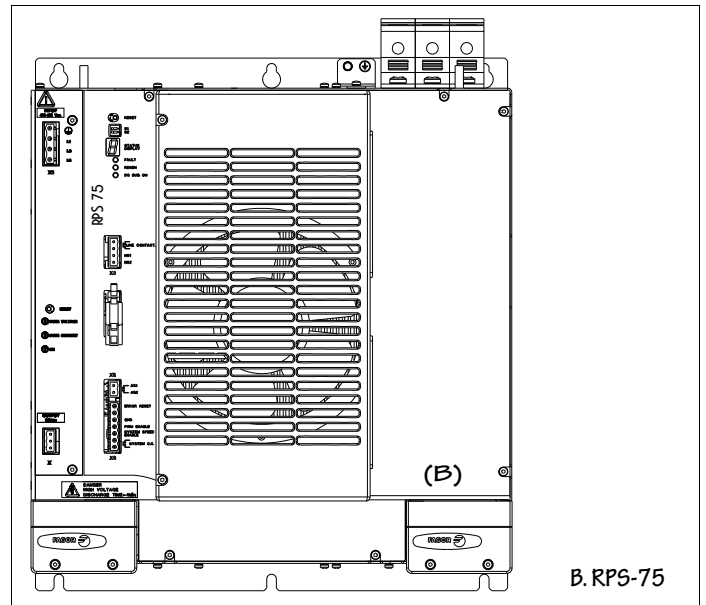
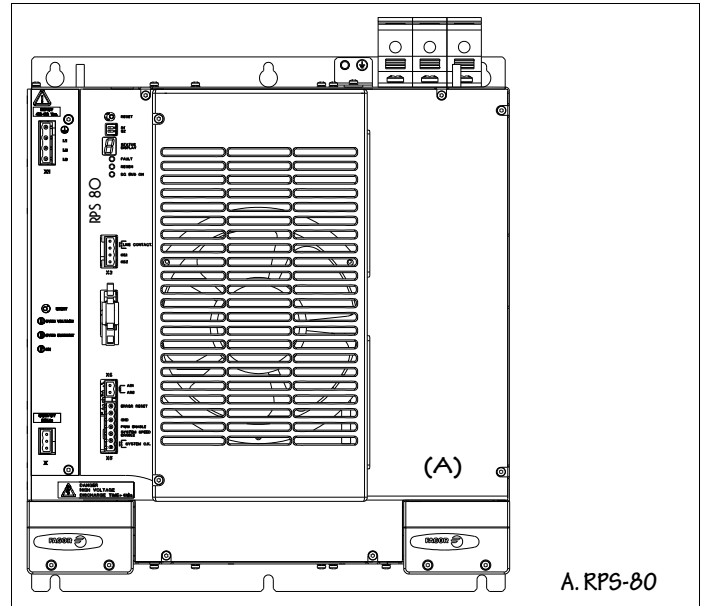

AXIS DRIVE MODULE, AXD

Digital module that can govern a synchronous motor in speed and position.

SPINDLE DRIVE MODULE, SPD

Digital module that can govern a asynchronous motor in speed and position.

MODULAR MOTION CONTROL, MMC

Digital module that can govern a synchronous motor in speed and position and also generate a tool path.

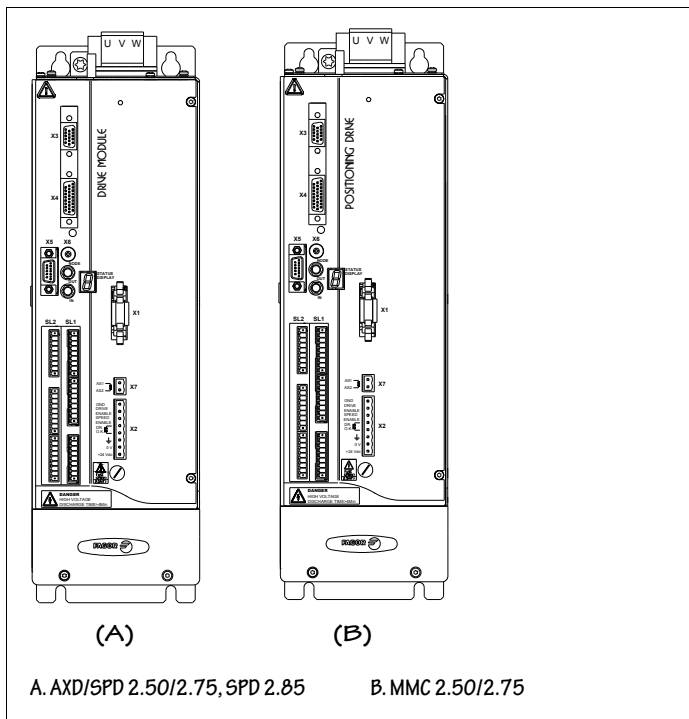
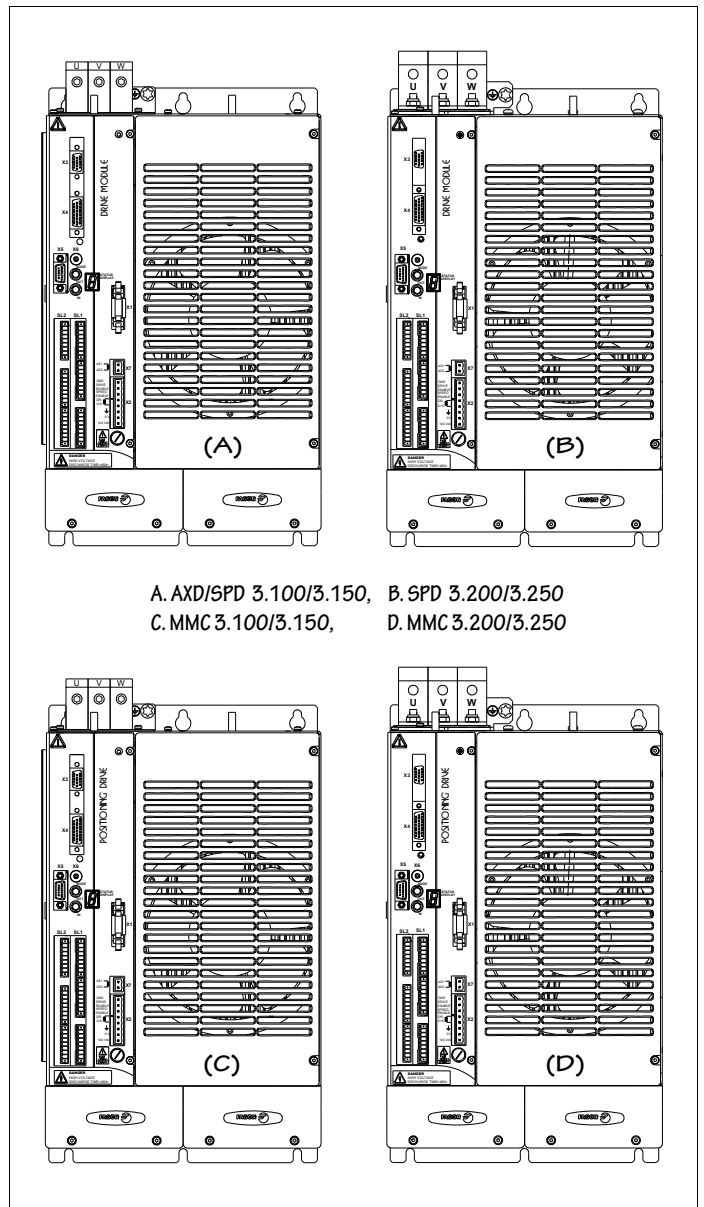
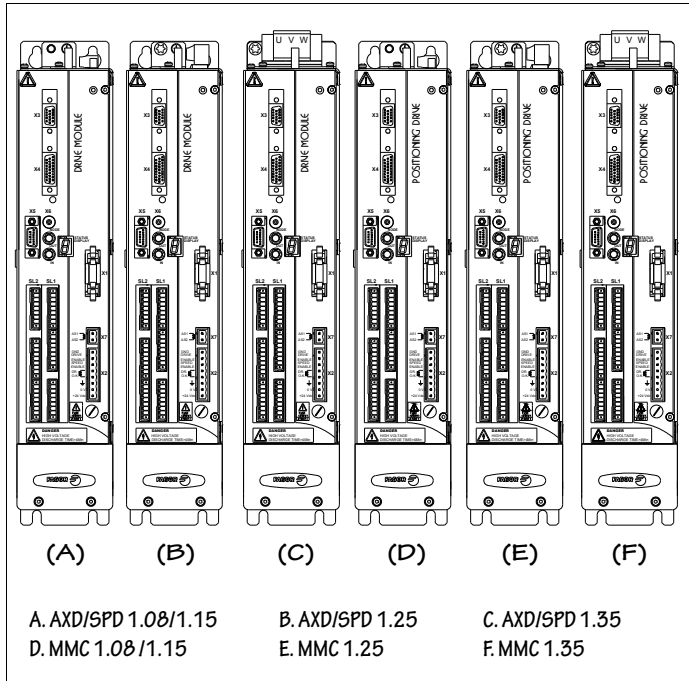

AUXILIARY POWER SUPPLY MODULE, APS-24

Module in charge of supplying 24 V DC to the control circuits of the rest of the modules. This power supply guarantees maintaining the 24 V DC for as long as the motor braking lasts after a mains outage.

Note. This is an absolute must to meet the requirements of the EC seal on the machine.



MANDATORY. If necessary, the auxiliary power supply APS-24 (24 V DC, 10 A) can only be connected to the DC bus of any regenerative power supply XPS or RPS when the version label of the APS-24 (located on top of it) indicates a version PF 24A or newer.



MANDATORY. The auxiliary power supply APS-24 (24 V DC, 10 A) may be connected to the DC bus with any non-regenerative power supply regardless of the version indicated on its label.



WARNING. Never install an APS-24 to the DC bus of a DDS system with a regenerative power supply XPS or RPS if the version of the APS-24 is PF 23A or older.

RESISTOR MODULE, ER+TH-X/X & ER+TH-18/X+FAN

External resistors are used to dissipate the excess of energy generated at the power bus in a braking process of electrical motors and cannot be dissipated by the internal resistor of the module (power supply). These resistors do not require external electrical supply.

CAPACITOR MODULE, CM-1.75

This module stores the energy returned while the motors are braking. The capacitor module should also be used when having systems that sporadically request high current peaks from the power bus hence increasing the bus' own capacity.

From the energy point of view, installing a capacitor module is more efficient than installing external braking resistors.

BUS PROTECTION MODULE, BPM

Install in DDS systems having:

Synchronous spindle and only when required by the application.

Purpose. Protect the power semi-conductors (IGBTs) of the drive that governs it, thus preventing damage to the unit due to a very high voltage that may be generated at the power bus because the braking energy cannot be returned when a voltage drop occurs and/or,

RPS pow. supply when only the controlled stop is to be ensured.

Purpose. To ensure a controlled stop of the motor due to mains failure because the energy may be dissipated while braking at the external Ballast resistors installed in the BPM module. Not installing this module will result in an uncontrolled stop (by inertia) in case of a voltage failure due to an over-voltage error of the bus because there are no resistors to dissipate the braking energy.

MAINS FILTER

Absolutely necessary for complying with the European Directive on Electromagnetic Compatibility 2004/108/EC or the International Standard CEI/IEC 1800-3. The filter MAIN FILTER 42A is designed for PS-25B4, XPS-25 and RPS-20, MAIN FILTER 130A-A is designed for PS-65A, MAIN FILTER 130A is designed for XPS-65, RPS-75, MAIN FILTER 75A is designed for RPS-45 and MAIN FILTER 180A is designed for RPS-80.

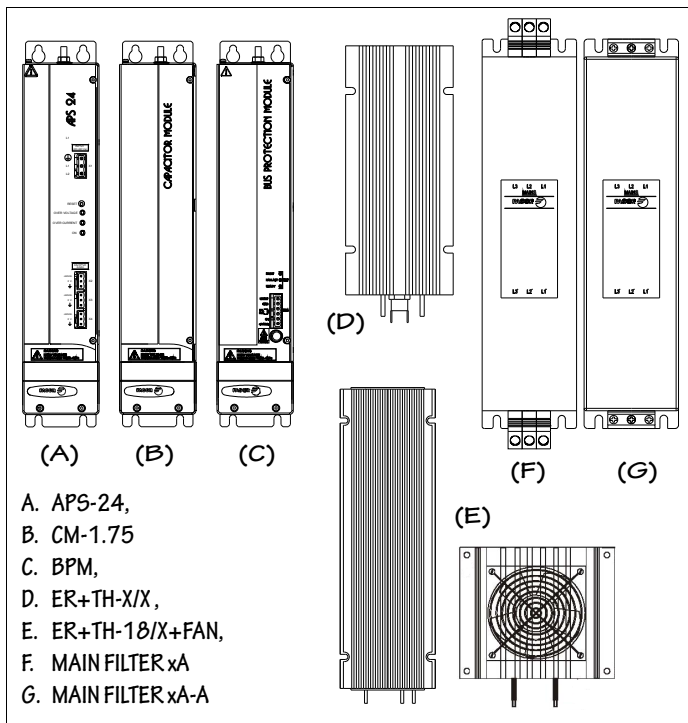

CHOKES XPS AND CHOKES RPS

The chokes (inductance) must only be installed with regenerative power supplies (XPS and RPS).

XPS power supplies have their own associated XPS choke. RPS power supplies have their own associated RPS choke.

When returning power to mains, the impedance of mains for the outgoing currents is very low. Thus, the up ramps of this current must be limited with a choke.

Note. This system has been manufactured in accordance with the EN 60204-1 Standard in compliance with European Directive 2006/95/EC on Low Voltage.

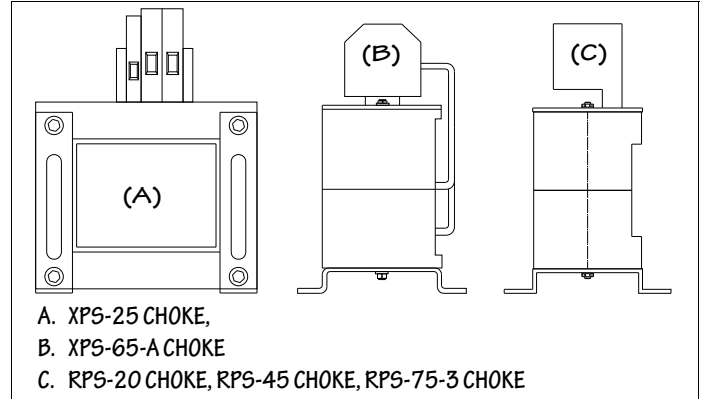

SELECTING THE BALLAST RESISTOR ON PS-25B4 AND PS-65A POWER SUPPLIES

Non-regenerative power supplies PS-25B4 and PS-65A have three micro-switches for selecting the external Ballast resistor.

It is also possible to disable the «I_t» protection when selecting the internal resistor or having the RM-15 module (discontinued) because they both include a protection with their own thermostat protection.

A. PS-65A, B. PS-25B4

TOP VIEW (A)

S3	S2	S1	RESISTOR
OFF	OFF	OFF	INTERNAL
OFF	OFF	ON	ER+TH-18/1100
OFF	ON	OFF	ER+TH-18/1000+FAN
OFF	ON	ON	ER+TH-18/1800
ON	OFF	OFF	ER+TH-18/2200
ON	ON	OFF	RM-15
ON	OFF	ON	DISABLED
ON	ON	ON	DISABLED

■ REPRESENTS THE MOVING ELEMENT.

On PS-25B4 power supplies, install the indicated resistor.
On PS-65A power supplies, install in parallel 2x the indicated resistor.

POWER SUPPLY MODULES. PS-65A

Technical data

	PS-65A
Power supply (Vmains) ²	Three phase 50/60 Hz with a voltage range between 400 V AC-10 % & 460 V AC+10 %
Mains power consumption	100 Arms
Max. connection cable section	50 mm ²
Power bus voltage VBUSnom	565 V DC - 650 V DC
Rated (peak) output current	120 A (360 A, 1 s)
Rated (peak) output power ¹	65 kW (195 kW, 1 s)
Power for the module control circuit	24 V DC (between 21-28 V DC)
Consumption of the module control circuit itself	1 A at 24 V (24 W)
Internal Ballast resistance (power) ¹	9 Ω (600 W)
Energy pulse to be dissipated	36 kWs (0.6 s)
Ballast circuit ON/OFF ³	768 V DC / 760 V DC (712 V DC / 704 V DC)

Min. external Ballast resistance	9 Ω
Filter capacity	940 μF, 900 V DC
Energy stored in the capacitors	0.5 C·V ²
Max. SYSTEM OK contact voltage	125 V AC, 150 V AC
Max. SYSTEM OK contact current	2 A
Module width	117 mm / 4.61 in
Module weight	9.9 kg / 22 lb
Power dissipated at max. load	275 W
Ambient temperature ¹	0°C/45°C (32°F/113°F)
Storage temperature	-25°C/60°C (-13°F/140°F)
Maximum humidity	< 90% non condens. at 45°C/113°F
Max. installation altitude	2000 m (6561 ft) above sea level
Operating/shipping vibration	1 g / 1.5 g
Sealing	IP 2x
Protections	Overvoltage, heat-sink temperature, hardware error, Ballast overload.

1 See derating curves in case of high temperatures.

2 Previous power supplies PS-XX only admitted Vmains of 400 V AC.

3 When the module is set for Vmains = 400 V AC, as same PS-XX.

POWER SUPPLY MODULES, PS-25B4

Technical data

	PS-25B4
Power supply (Vmains) ¹	Three-phase 50/60 Hz with a voltage range 400-10% and 460+10% V AC
Mains power consumption	38 Arms
Max. connection cable section	10 mm ²
Power bus voltage VBUSnom ³	565 V DC / 650 V DC
Rated (peak) output current	45 A (135 A, 1 s)
Rated (peak) output power	25 kW (75 kW, 1 s)
Internal Ballast resistance	16.5 Ω (500 W)
Energy pulse to be dissipated	6 kWs (0.2 s)
Ballast circuit ON/OFF ²	768 V DC / 760 V DC (712 V DC / 704 V DC)
Min. external Ballast resistance	16.5 Ω
Filter capacity	820 μF, 900 V DC
Energy stored in the capacitors	0.5 C·V ²
Max. SYSTEM OK contact voltage	125 V AC, 150 V DC
Max. SYSTEM OK contact current	2 A
Module width	77 mm/3.03 in
Module weight	6.0 kg/13.2 lb
Power dissipated at max. load	180 W
Output voltage, max. current	24 V DC (5 %), 10 A
Input voltage	400 V AC -10% and 450 V AC +10% 50/60 Hz
Mains consumption	0.72 A (400 V AC); 0.63 A (460 V AC)
Max. Inrush current	23.9 A (460 V AC)
Bus consumption	0.485 A (565 V DC); 0.44 A (650 V DC)
Bus max. voltage	790 V DC
Ambient temperature ³	0°C/45°C (32°F/113°F)
Storage temperature	-25°C/+60°C (-13°F/+140°F)
Maximum humidity	< 90% non condens. at 45°C/113°F
Max. installation altitude	2000 m (6561 ft) above sea level
Operating/shipping vibration	1 g / 1.5 g
Sealing	IP 2x
Protections	Overvoltage, heat-sink temperature, hardware error, Ballast overload

1 Previous power supplies PS-XX only admitted Vmains of 400 V AC.

2 When the module is set for 400 V AC, like the PS-25B3, or like the previous PS-XX.

3 See derating curves in case of high temperatures.

POWER SUPPLY MODULES. XPS-25 AND XPS-65

Technical data

	XPS-25	XPS-65
Power supply (Vmains)	Three-phase 50/60 Hz with a voltage range 400-10 % and 460+10 % V AC	
Mains power consumption	38 Arms	100 Arms
Max. connection cable section	16 mm ²	50 mm ²
Power Bus voltage VBUSnom	565 V DC / 650 V DC	
Rated (peak) output current ¹	45 A (100 A, 1s)	120 A (120 A, 1s)
Rated (peak) output power	25 kW (55 kW, 1s)	65 kW (108 kW, 1s)
Regenerating circuit ON/OFF voltage	Vmains x 1.414 + 30 V	
Rated regenerated current (returned to mains) ¹	25 Arms	62 Arms
Rated regenerated power (returned to mains) ¹	20 kW	50 kW
Choke-drive cable - max length: 2 m (80 in) -	16 mm ²	50 mm ²
Output voltage of the auxiliary power supply	24 V DC ± 5 %	
Max. current supplied	8 A at 24 V (192 W)	
Mains consumption for 24 V DC generation	0.72 A (400 V AC), 0.63 A (460 V AC)	
Internal Ballast resistance (power) ¹	18 Ω (520 W)	9 Ω (1800 W)
Energy pulse to be dissipated	18 kW (0.6 s)	50 kW (1 s)
Ballast circuit ON/OFF ²	765 V DC / 755 V DC (616 V DC / 608 V DC)	
Min. external Ballast resistance	18 Ω	9 Ω
Filter capacity	1175 µF, 900 V DC	2520 µF, 900 V DC
Energy stored in the capacitors	0.5 C·V ²	
Max. SYSTEM OK contact voltage	125 V AC, 150 V DC	
Max. SYSTEM OK contact current	2 A	
Module width	194 mm/7.64 in	234 mm/9.21 in
Module weight	14 kg/31 lb	19 kg/42 lb
Power dissipated at max. load	180 W	350 W
Ambient temperature ¹	0°C/45°C (32°F/113°F)	
Storage temperature	-25°C/+60°C (-13°F/140°F)	
Maximum humidity	< 90% non condens. at 45°C/113°F	
Max. installation altitude	2000 m (6561 ft) above sea level	
Operating/shipping vibration	1 g / 1.5 g	
Sealing	IP 2x	
Protections	Overvoltage, heat-sink temperature, hardware error, Ballast overload	

1 See derating curves in case of high temperatures.

2 When the module is set for Vmains = 400 V AC.

RPS POWER SUPPLY MODULES

Bus voltage selector switches

The two switches located between the electronic status display and the RESET button may be used to program a particular value of the voltage command at the power DC BUS DC. Thus, depending on the selected switch settings (configurations), the power supply will work in booster mode (RPS mode), boosting the mains voltage rectified at the DC BUS or in rectifier mode (RB6 mode) keeping the mains voltage rectified at the DC BUS regardless of the value of the mains voltage.

Configurations

The user must configure the RPS power supply with:

1. The minimum bus voltage required to properly meet the features required by the system (especially with the needs of the motors installed) and
2. A voltage command no lower than 1.41xVmains, approximately.

The possible configuration it offers are:

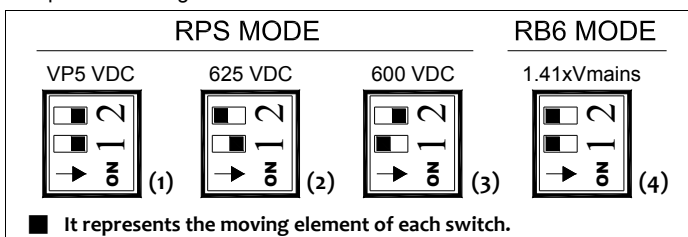

INFORMATION. The power supplies are factory set according to option 2, i.e. 625 V DC. **IMPORTANT.** Option 4, configuration in RB6 MODE, it only works when having RPS power supply version 03.01 or higher. When having an older version, bear in mind that the DC bus voltage command set at 675 V DC.

Technical data

	RPS-80	RPS-75	RPS-45	RPS-20
Power supply (Vmains)	Three-phase 50/60 Hz, with a voltage range 400-10 % and 460+10 % V AC			
Rated mains power active consumption in RPS mode (cosφ ≠ 1)	81 kW	76 kW	46 kW	21 kW
Rated mains power active consumption in RB6 mode (cosφ ≈ 0.9)	81 kW	76 kW	46 kW	21 kW
Min. section of power cable ¹	70 mm ²	70 mm ²	35 mm ²	10 mm ²
Power bus voltage	V BUS PROG: 600, 625 or 675 V DC. Programmable with VP5.			
Max. bus voltage VBUSmax	V BUS MAX: 750 V DC			
Rated (in S1) output current in RPS mode ²	128 A	120 A	72 A	32 A
Rated (in S1) output power in RPS mode ³	80 kW	75 kW	45 kW	20 kW
Max. regenerative power in RB6/RPS mode	75/104 kW	75/97 kW	39/59 kW	19/26 kW
Max. consumption power in RB6/RPS mode	97/104 kW	97/97 kW	55/59 kW	26/26 kW
Power dissipated with load	1 kW	1 kW	0.7 kW	0.5 kW
Associated CHOKE	RPS-75-3		RPS-45	RPS-20
Choke-drive cable. Max length: 2 m (78.7 in) ¹	70 mm ²	70 mm ²	35 mm ²	10 mm ²
Voltage supply of the module control circuit (24 V DC)	Three-phase 50/60 Hz, with a voltage range 400-10 % and 460+10 % V AC			
Mains consumption for 24 V DC generation	0.7 A			
Output voltage of auxiliary power supply	24 V DC ± 5 %			
Max. current supplied	8 A at 24 V DC (192 W)			
Ballast circuit ON/OFF	765 V DC / 755 VDC			
Filter capacity	2145 µF, 900 V	2145 µF, 900 V	825 µF, 900 V	560 µF, 900 V
Energy stored at the capacitors	0.5 C·V ²			
Max. voltage at contacts SYSTEM OK, LINE CONTACT & AS1-AS2	125 V AC, 150 V DC			
Max. current at contacts SYSTEM OK, LINE CONTACT & AS1-AS2	2 A			
Module width	350 mm 13.8 in	350 mm 13.8 in	311 mm 12.2 in	194 mm 7.6 in
Module approx. mass	20 kg 44.1 lb	20 kg 44.1 lb	16 kg 35.3 lb	10 kg 22.0 lb
Ambient temperature ³	0°C/45°C (32°F/113°F)			
Storage temperature	-25°C/60°C (-13°F/140°F)			
Maximum humidity	< 90 % non condensing at 45°C/113°F			
Max. installation altitude	2000 m / 3281 ft above sea level			
Operating vibration	1 g			
Shipping vibration	1.5 g			
Sealing	IP 2x			
Protections	Overvoltage, heat-sink temperature, hardware error, Ballast overload			

1 It will depend on the rated operating power.

2 For a bus voltage of 625 V DC.

3 For high temperatures, refer to the derating graphs.

AXIS DRIVE MODULES. AXD/MMC

With internal FAN	AXIS DRIVE AXD									
Currents (Arms) at fc=4 kHz	1.08	1.15	1.25	1.35	2.50	2.75	2.85	3.100	3.150	3.200
I S1=In (Arms)	4.0	7.5	12.5	17.5	25.0	37.5	-	50.0	75.0	90.0
I max S1 (Arms)	8.0	15.0	25.0	35.0	50.0	75.0	-	100.0	150.0	180.0
Dissipat. power	33	69	88	156	225	270	-	351	536	834

With internal FAN	AXIS DRIVE AXD									
Currents (Arms) at fc=8 kHz	1.08	1.15	1.25	1.35	2.50	2.75	2.85	3.100	3.150	3.200
I S1=In (Arms)	4.0	7.5	12.5	17.5	25.0	37.5	-	50.0	75.0	90.0
I max S1 (Arms)	8.0	15.0	25.0	35.0	50.0	75.0	-	100.0	150.0	180.0
Dissipat. power	44	89	132	195	305	389	-	510	605	840

SPINDLE DRIVE MODULES. SPD

With internal FAN	SPINDLE DRIVE SPD								
Currents (Arms) at fc=4 kHz	1.25	1.35	2.50	2.75	2.85	3.100	3.150	3.200	3.250
I S1=In (Arms)	16.0	23.1	31.0	42.0	50.0	70.0	90.0	121.0	135.0
0.7xIn (Arms)	11.2	16.1	21.7	29.0	35.0	49.0	63.0	84.7	94.5
I S6-40% (Arms)	20.8	30.0	40.3	54.6	65.0	91.0	117.0	157.3	175.5
Dissipat. power (W)	110	195	349	389	432	496	626	1163	1333

With internal FAN	SPINDLE DRIVE SPD								
Currents (Arms) at fc=8 kHz	1.25	1.35	2.50	2.75	2.85	3.100	3.150	3.200	3.250
I S1=In (Arms)	13.0	18.0	27.0	32.0	37.0	56.0	70.0	97.0	108.0
0.7xIn (Arms)	9.1	12.6	18.9	22.4	25.9	39.2	49.7	67.9	75.6
I S6-40% (Arms)	16.9	23.4	35.1	41.6	48.1	72.8	91.0	126.1	140.4
Dissipat. power (W)	130	201	350	333	438	546	668	1187	1344

Technical data

	AXD/SPD/MMC		
	1.08, 1.15 1.25, 1.35	2.50 2.75, 2.85	3.100, 3.150 3.200, 3.250
Power voltage input	542-800 V DC		
Power to control circuits	24 V DC (between 21-28 V DC)		
Consumption on these circuits (24 V DC)	0.9 A	1.25 A	2 A
Speed feedback	Encoder		
Controlling method	PWM, AC sinewave, vector control		
Communications	Serial line to connect to a PC		
Interface	Standard analog or digital via SERCOS ring or CAN bus (in all models) Serial line RS-232/RS-422 (only in MMC drives)		
Status display	7 - segment display		
Protections	Overvoltage, overcurrent, overspeed, heat-sink, temperature, CPU temperature, motor temperature, hardware error, overload.		
Frequency ¹	Lower than 600 Hz		
Speed range with analog input	1:8192		
Current bandwidth	800 Hz		
Speed bandwidth	100 Hz (depends of the motor/drive set)		
Ambient temperature ²	0°C/45°C (32°F/113°F)		
Storage temperature	-25°C/60°C (-13°F/140°F)		
Sealing	IP 2x		
Maximum humidity	< 90 % (non condensing at 45°C/113°F)		
Max. installation altitude	2000 m / 3281 ft above sea level		
Operating vibration	1 g		
Shipping vibration	1.5 g		
Approx. mass, kg/lb	6.0/33.2	10.0/22.0	13.6/29.9

1 Equal to or higher than 600 Hz only for commercial models SPD ... - MDU (dual-use). 2 For high temperatures, refer to derating graphs (power reduction graph).

CHOKES

CHOKE for XPS power supply. Technical data

CHOKE	XPS-25	XPS-65-A
Inductance (10 kHz)	0.350 mH	0.250 mH
Rated current	50 A	120 A
Peak current	100 A	185 A
Max. terminal section	10 mm ²	70 mm ²
Operating ambient temperature	5°C/45°C (41°F/113°F)	
Storage temperature	-20°C/60°C (-4°F/140°F)	
Relative humidity	80 % max.	
Operating vibration	0.5 g	
Shipping vibration	2 g	
Sealing	IP 20	
Approx. mass, kg (lb)	8.0 (17.6)	12.0 (26.4)

CHOKE for RPS power supply. Technical data

CHOKE	RPS-20	RPS-45	RPS-75-3
Inductance (8 kHz)	0.90 mH	0.40 mH	0.175 mH
Rated current	32 A	72 A	180 A
Min. section cable	10 mm ²	35 mm ²	70 mm ²
Operating ambient temperature	0°C/60°C (32°F/140°F)		
Storage temperature	-20°C/60°C (-4°F/140°F)		
Relative humidity	< 90 % (non condensing at 45°C/113°F)		
Operating/shipping vibration	0.5 g / 2 g		
Sealing	IP 20		
Approx. mass, kg (lb)	12.7 (28.0)	20.4 (44.9)	36.0 (79.3)

EXTERNAL BALLAST RESISTOR

With external thermostat. Technical data

ER+TH-00/0000	24/750	24/1100	18/1100
Resistance	24 Ω	24 Ω	18 Ω
RMS power	650 W	950	950 W
Energy absorbed in 5" overloaded	37 kJ	55 kJ	55 kJ
Operating ambient temperature	5°C/45°C (41°F/113°F)		
Storage temperature	-20°C/60°C (-4°F/140°F)		
Relative humidity	< 90 % (non condensing at 45°C/113°F)		
Operation/shipping vibration	0.5 g / 2 g		
Sealing	IP 55		
Approx. mass, gr (lb)	920 (2.02)	1250 (2.75)	



WARNING. Be careful with the surface of the resistors. Remember that its temperature may reach 400°C (752°F).

With internal thermostat. Technical data

ER+TH-00/0000	18/1800	18/2200
Resistance	18 Ω	18 Ω
RMS power	1300 W	2000 W
Energy absorbed in 5" overloaded	55 kJ	83 kJ
Operating ambient temperature	5°C/45°C (41°F/113°F)	
Storage temperature	-20°C/60°C (-4°F/140°F)	
Relative humidity	< 90 % (non condensing at 45°C/113°F)	
Operation/shipping vibration	0.5 g / 2 g	
Sealing	IP 54	
Approx. mass, kg (lb)	3.0 (6.60)	6.2 (13.66)



WARNING. Be careful with the surface of the resistors. Remember that its temperature may reach 410°C (770°F).

With internal thermostat and fan. Technical data

ER+TH-00/0000+FAN	18/1000	18/1500	18/2000
Resistance	18 Ω	18 Ω	18 Ω
RMS power	2 kW	3 kW	4 kW
Operating ambient temperature	-10°C/40°C (14°F/104°F)		
Storage temperature	-20°C/60°C (-4°F/140°F)		
Relative humidity	< 90 % (non condensing at 45°C/113°F)		
Running vibration	0.5 g		
Shipping vibration	2 g		
Sealing	IP 20 / IP 65 *		
Approx. mass, kg (lb)	6.0 (13.2)	7.0 (15.4)	8.0 (17.6)

* To maintain a sealing protection of IP 65, the surface temperature of the resistor must not exceed 200°C/392°F.



WARNING. Be careful with the surface of the resistors. Remember that its temperature may reach 300°C (572°F).

OMHAGE

The following table indicates how combine resistors ER-TH-18/□ (with thermostat) and ER-TH-18/□+FAN (with thermostat and cooling fan) to obtain the ohm value for each power supply.

PS-25B4	18 Ω	950 W	ER+TH-18/1100
		1.3 kW	ER+TH-18/1800
		2.0 kW	ER+TH-18/2200
		2.0 kW	ER+TH-18/1000+FAN
		3.0 kW	ER+TH-18/1500+FAN
		4.0 kW	ER+TH-18/2000+FAN
XPS-25	18 Ω	950 W	ER+TH-18/1100
		1.3 kW	ER+TH-18/1800
		2.0 kW	ER+TH-18/2200
		2.0 kW	ER+TH-18/1000+FAN
		3.0 kW	ER+TH-18/1500+FAN
		4.0 kW	ER+TH-18/2000+FAN
PS-65A	9 Ω	1.9 kW	2x ER+TH-18/1100 in parallel
		2.6 kW	2x ER+TH-18/1800 in parallel
		4.0 kW	2x ER+TH-18/2200 in parallel
		4.0 kW	2x ER+TH-18/1000+FAN in parallel
		6.0 kW	2x ER+TH-18/1500+FAN in parallel
		8.0 kW	2x ER+TH-18/2000+FAN in parallel
XPS-65	9 Ω	1.9 kW	2x ER+TH-18/1100 in parallel
		2.6 kW	2x ER+TH-18/1800 in parallel
		4.0 kW	2x ER+TH-18/2200 in parallel
		4.0 kW	2x ER+TH-18/1000+FAN in parallel
		6.0 kW	2x ER+TH-18/1500+FAN in parallel
		8.0 kW	2x ER+TH-18/2000+FAN in parallel

Note. The RPS power supplies do not carry a crowbar circuit and, consequently, do not have a Ballast resistor associated with them. If the application requires one, an off-the-shelf one will have to be installed.

CAPACITOR MODULE, CM-1.75

Technical data

Capacitor Module	CM-1.75
Capacity	7380 μF
Maximum bus voltage	797 V DC
Ambient temperature	0°C/45°C (32°F/113°F)
Storage temperature	-25°C/60°C (-13°F/140°F)
Relative humidity	< 90% (non condensing at 45°C/113°F)
Operating/shipping vibration	1 g / 1.5 g
Sealing	IP 2x
Approx mass, kg/lb	6.2/13.6

AUXILIARY POWER SUPPLY MODULE, APS-24

Technical data

Auxiliary Power Supply	APS-24
Output voltage, max. current	24 V DC (± 5 %), 10 A
Input voltage (single phase)	400-10 % / 460+10 % V AC, 50/60 Hz
Mains consumption	0.72 A (400 V AC), 0.63 A (460 V AC)
Maximum Inrush current	23.9 A (460 V AC)
Bus consumption	0.485 A (565 V DC), 0.44 A (650 V DC)
Maximum bus voltage	790 V DC
Ambient temperature	0°C/45°C (32°F/113°F)
Storage temperature	- 25°C/60°C (- 13°F/140°F)
Operating/shipping vibration	1 g / 1.5 g
Sealing	IP 2x
Approx. mass, kg/lb	4.3/9.4

BUS PROTECTION MODULE, BPM

Technical data

Bus Protection Module	BPM
Power voltage input	542-800 V DC
Control circuit voltage	24 V DC (between 22-26 V DC)
Control circuit consumption	0.1 A
Protections	Short-circuit, over-temperature
Ballast resistors	≥ 18 Ω. Up to three 18 Ω resistors may be connected without power limit
Maximum braking power	100 kW
Filter capacity	410 μF, 900 V DC
Max. voltage at DR OK contact	125 V AC, 150 V DC
Max. current at DR OK contact	1 A
Module width	77 mm
Approx. mass kg/lb	3.6/7.9
Ambient temperature	0°C/45°C (32°F/113°F)
Storage temperature	-25°C/60°C (-13°F/140°F)
Max. humidity	< 90% (non condensing at 45°C/113°F)
Max. altitude	2000 m (6561 ft) above sea level
Operating vibration	1 g
Shipping vibration	1.5 g
Sealing	IP 2x

DIMENSIONS

When making the electrical cabinet, also taken into account the necessary room for the connectors and their cables. Especially for the upper connectors which on the bigger modules can be up to 45 mm high.

Power supply modules

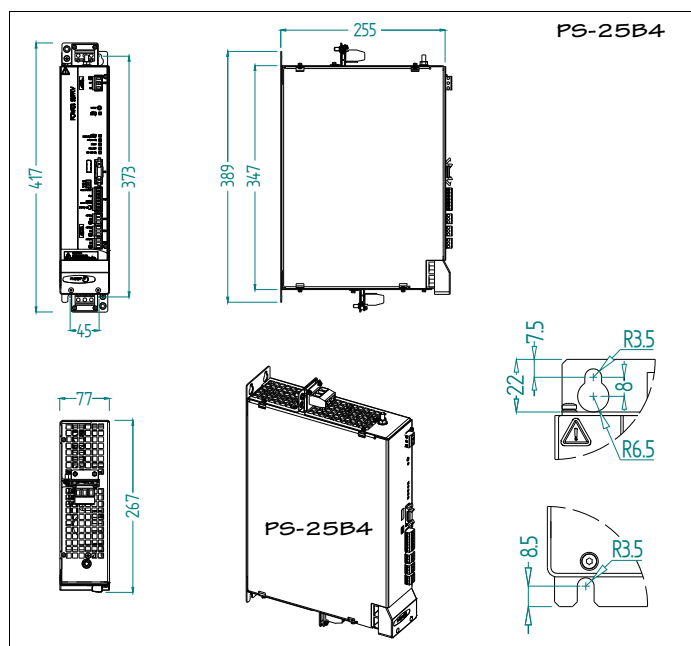

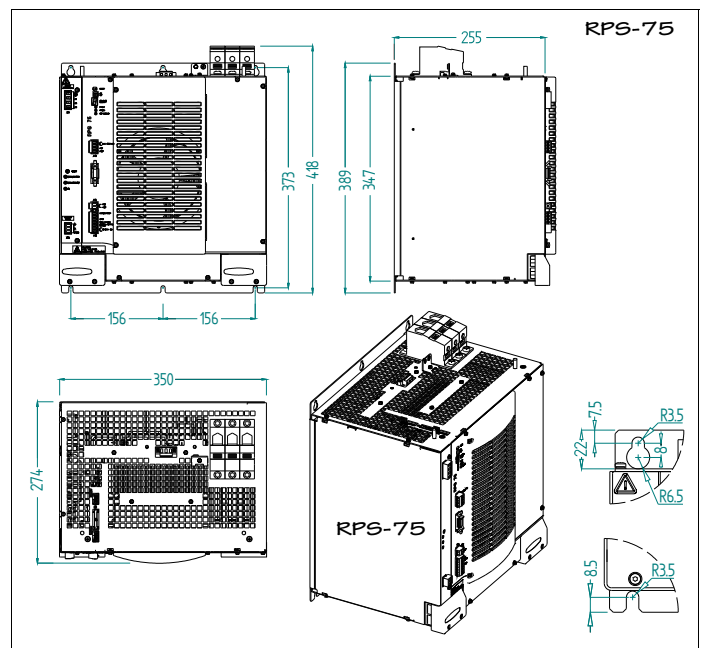
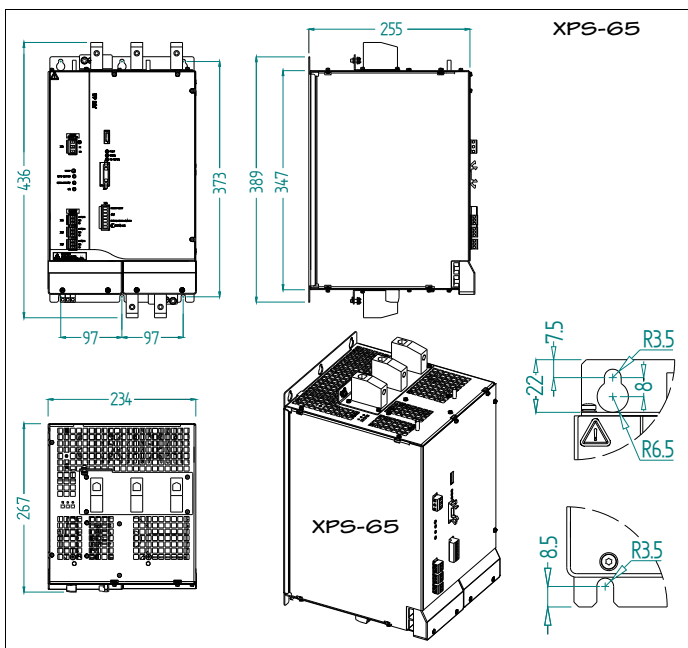
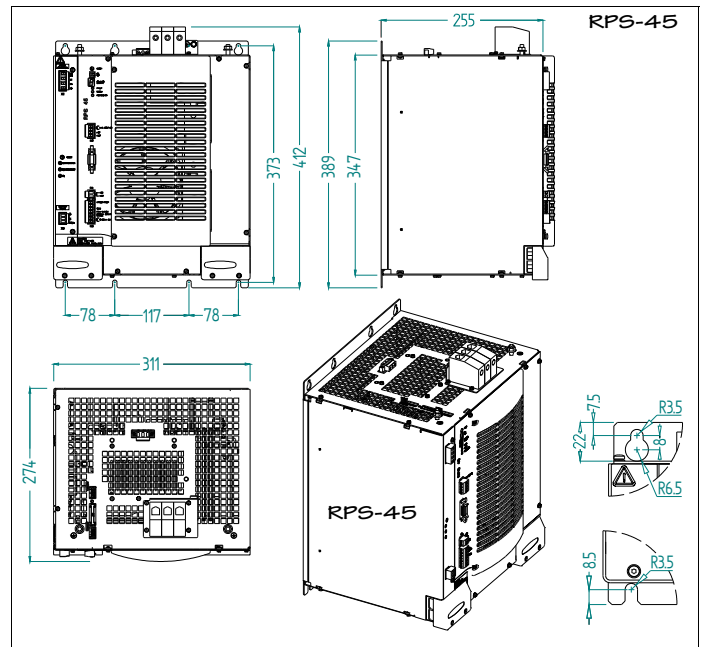
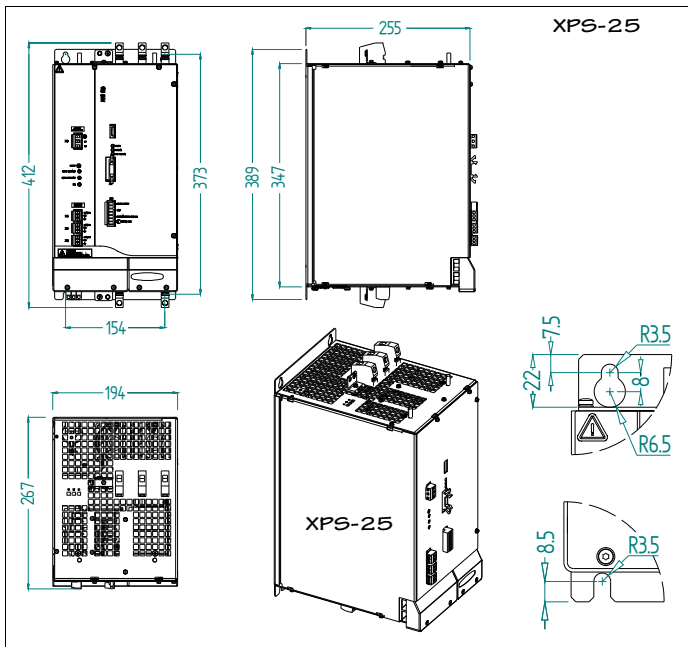
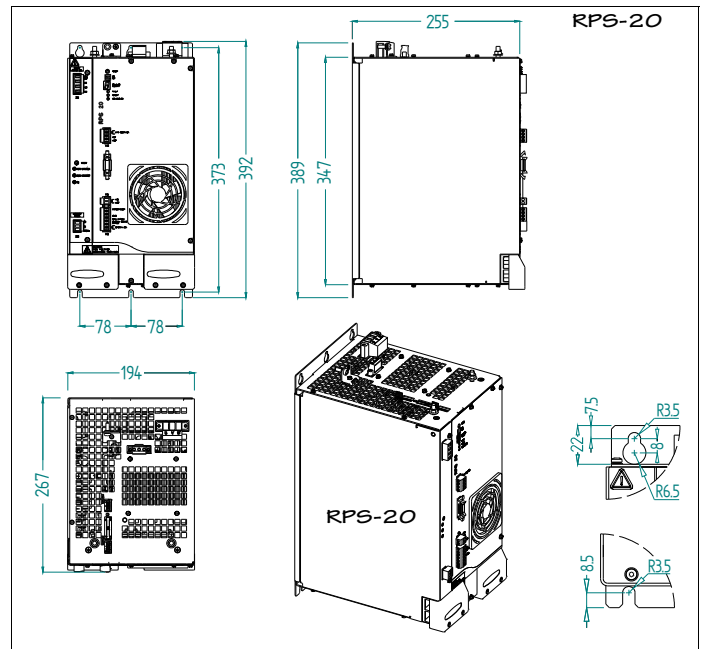
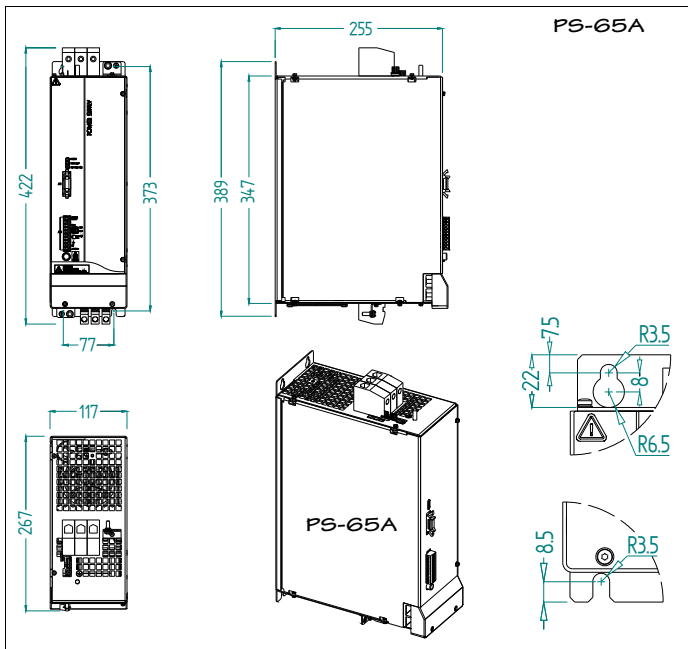

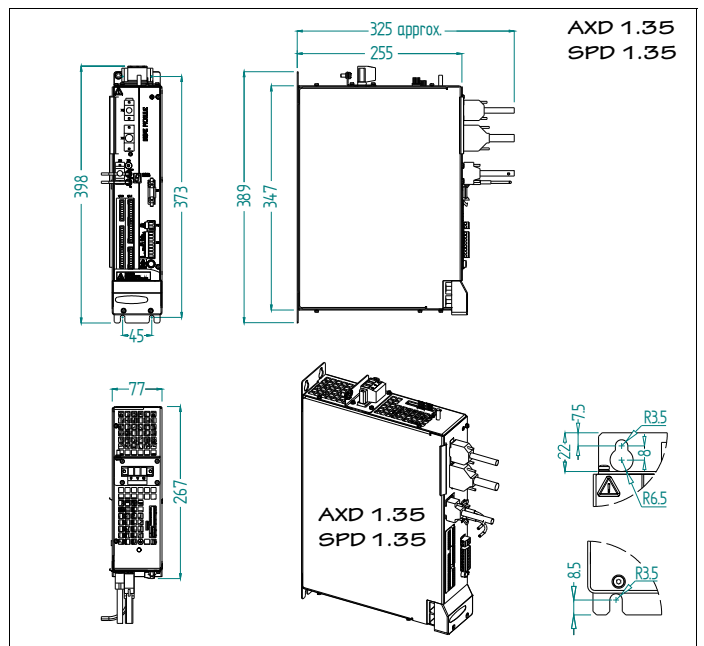
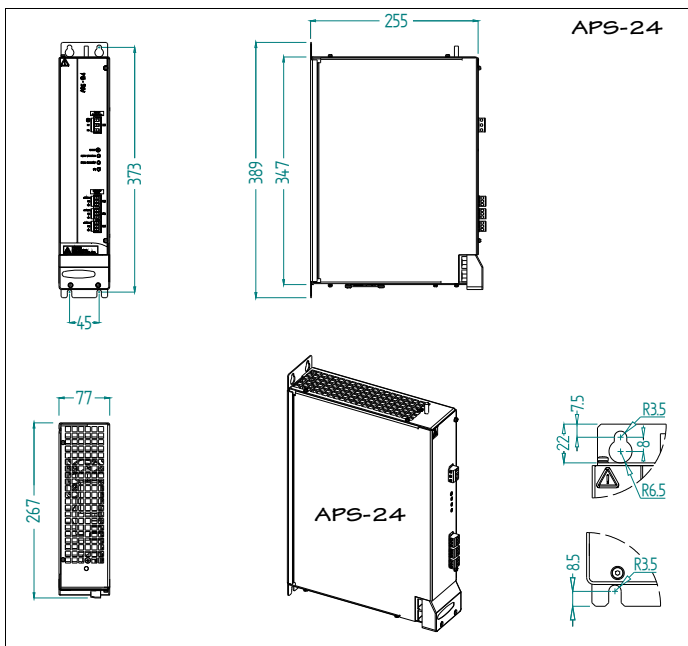
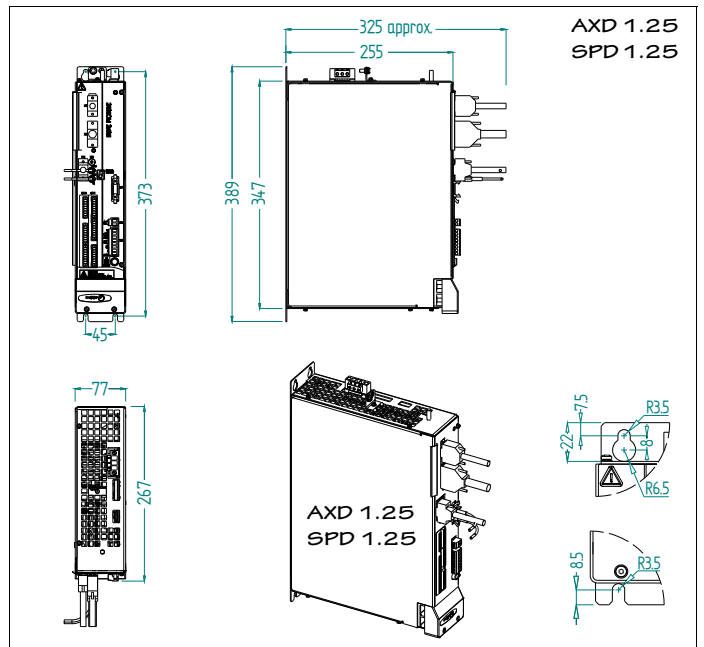
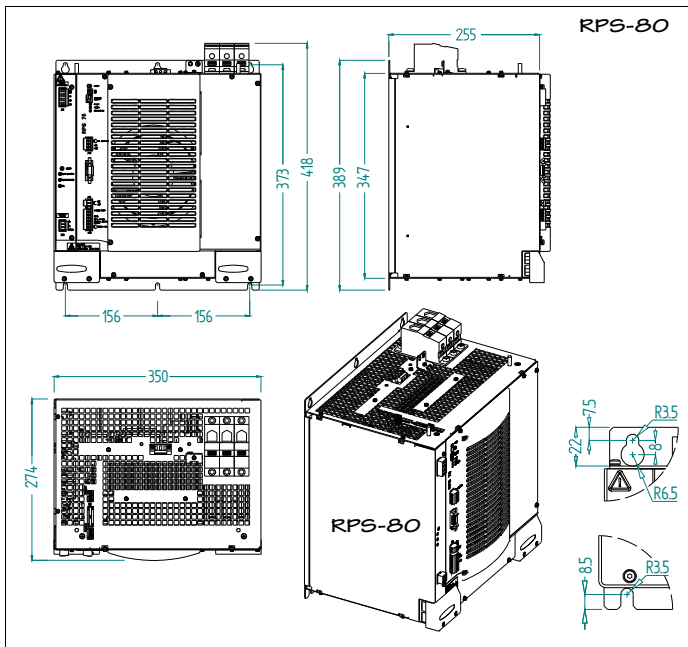

Modular drives modules

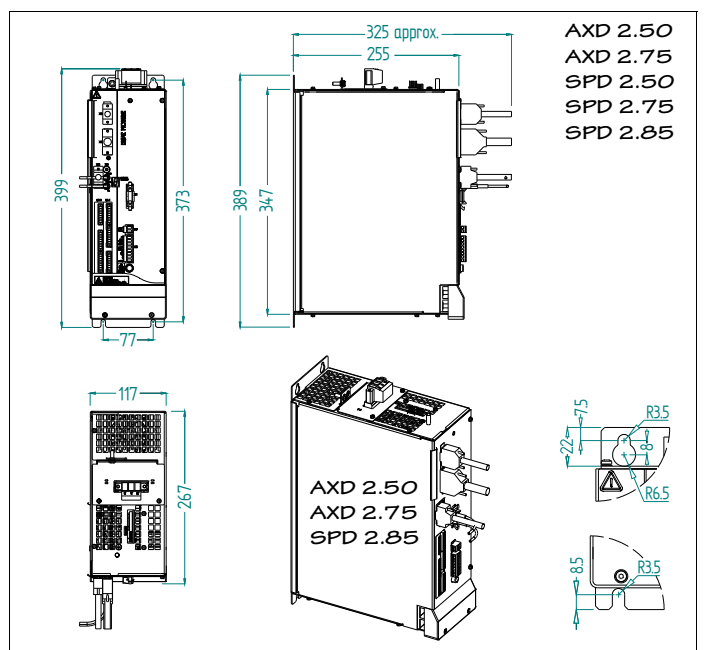
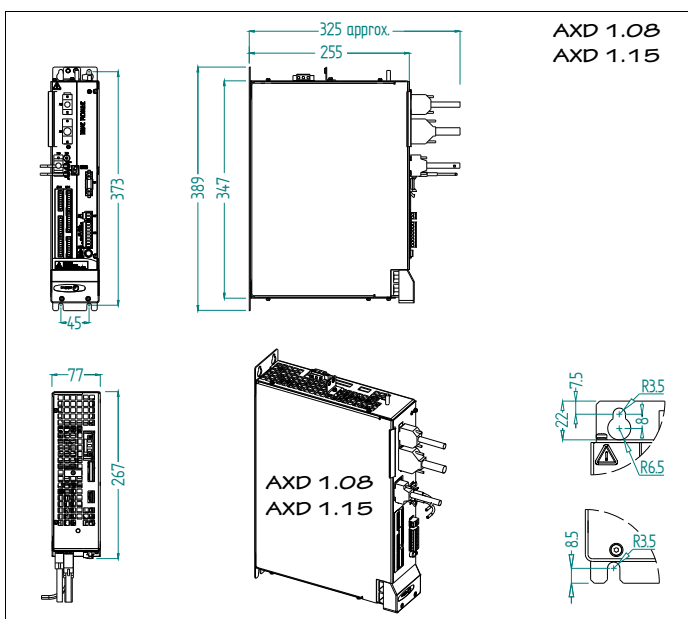

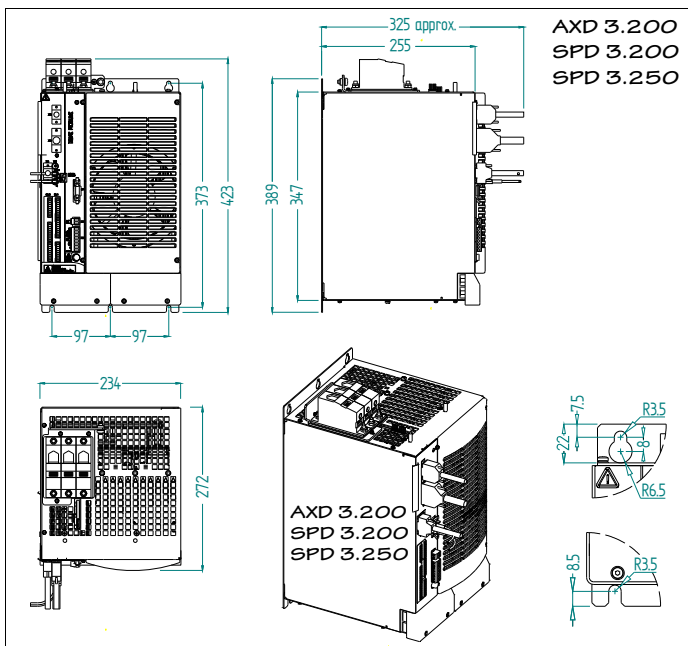
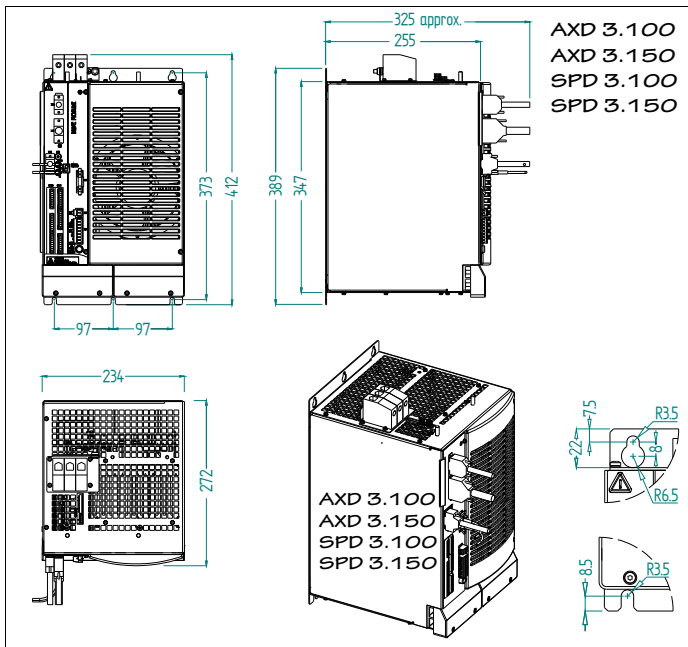

Capacitor module

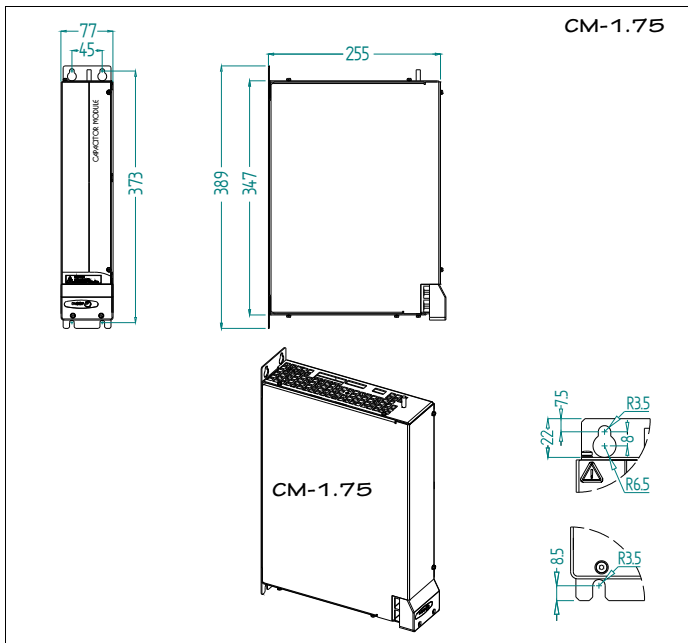

Bus Protection Module

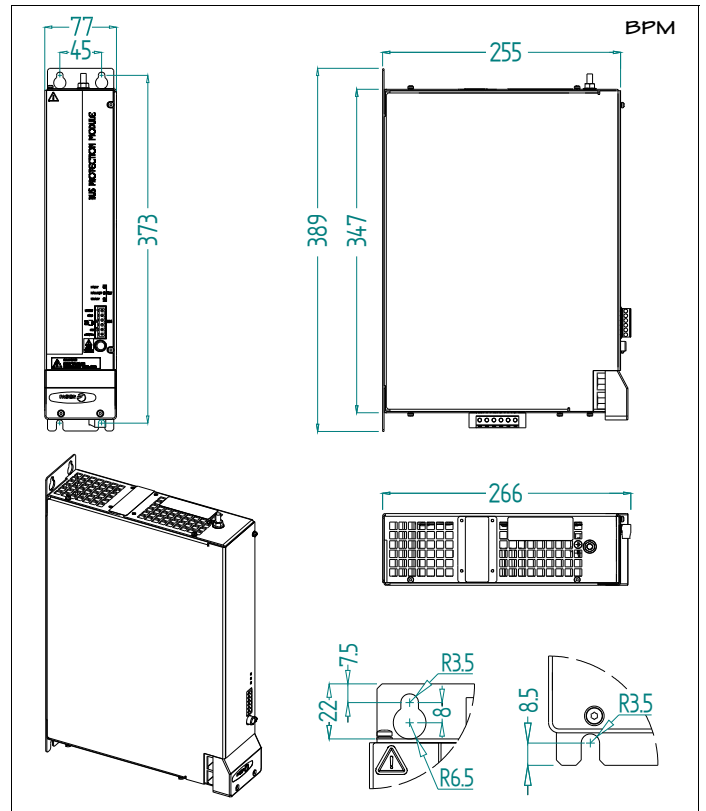

Mains filter

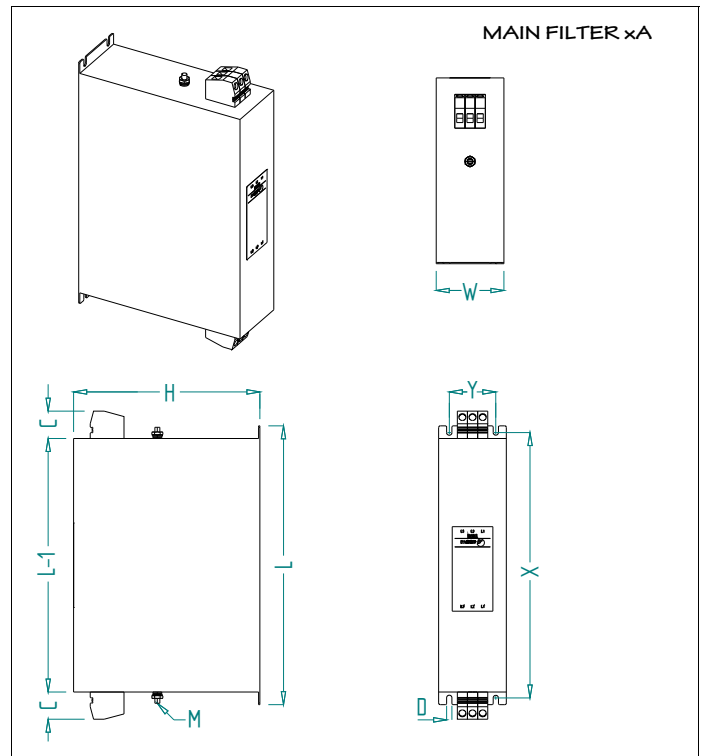

MAIN FILTER	42A		75A		130A		180A	
	mm	in	mm	in	mm	in	mm	in
Units								
L	330	12.99	330	12.99	440	17.32	440	17.32
L-1	300	11.81	300	11.81	400	15.74	400	15.74
C	15	0.59	40	1.57	45	1.77	45	1.77
W	70	2.75	80	3.15	110	4.33	110	4.33
H	185	7.28	220	8.66	240	9.44	240	9.44
X	314	12.36	314	12.36	414	16.29	414	16.29
Y	45	1.77	55	2.16	80	3.14	80	3.14
M	M6		M6		M10		M10	
D	M5		M6		M6		M6	

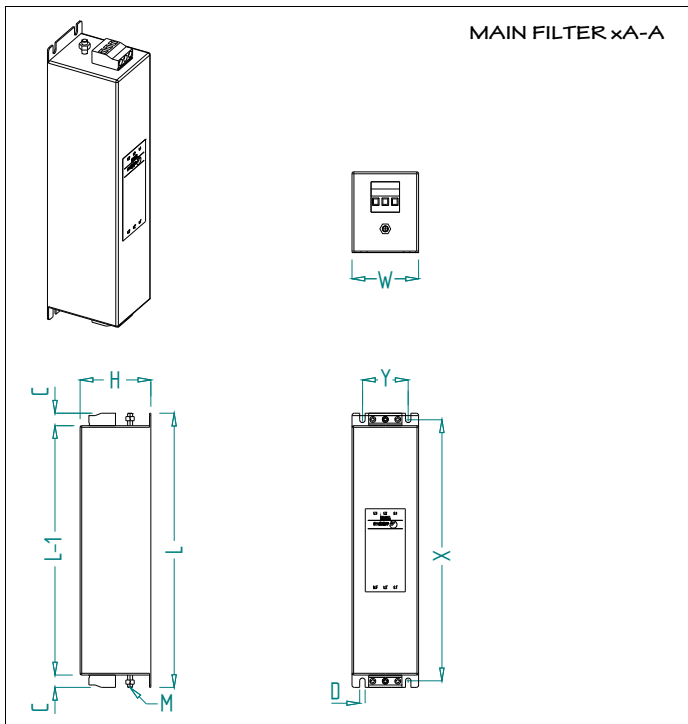

MAIN FILTER xA-A

MAIN FILTER	130A-A				
Units	mm	in			
L	440	17.32			
L-1	400	15.74			
C	45	1.77			
W	110	4.33			
H	150	5.90			
X	414	16.29			
Y	80	3.15			
M	M10				
D	M6				

External resistor with external thermostat

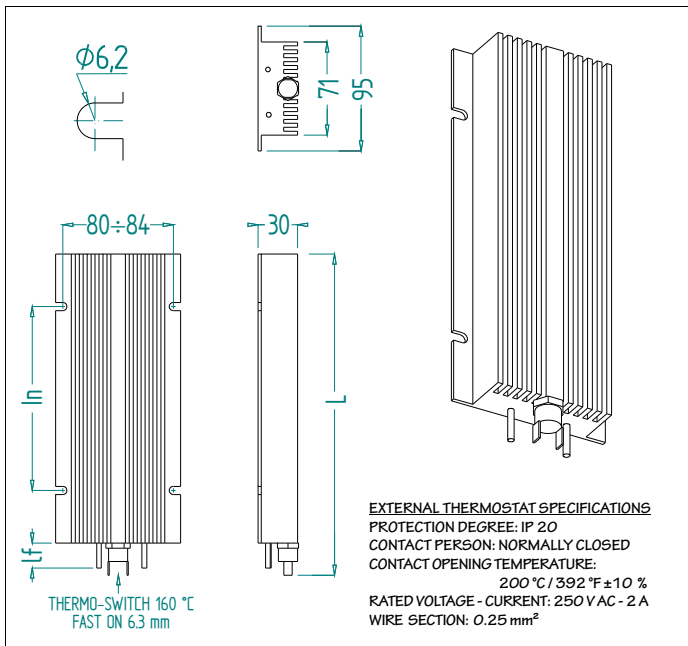

EXTERNAL THERMOSTAT SPECIFICATIONS
 PROTECTION DEGREE: IP 20
 CONTACT PERSON: NORMALLY CLOSED
 CONTACT OPENING TEMPERATURE:
 200°C / 392°F ±10 %
 RATED VOLTAGE - CURRENT: 250V AC - 2 A
 WIRE SECTION: 0.25mm²

	ER+TH-43/350		ER+TH-24/750		ER+TH-24/1000 ER+TH-18/1000	
Units	mm	in	mm	in	mm	in
L	110	4.33	220	8.66	320	12.59
ln	60	2.36	140	5.51	240	9.44
lf	300	11.81	300	11.81	300	11.81

External resistor with internal thermostat

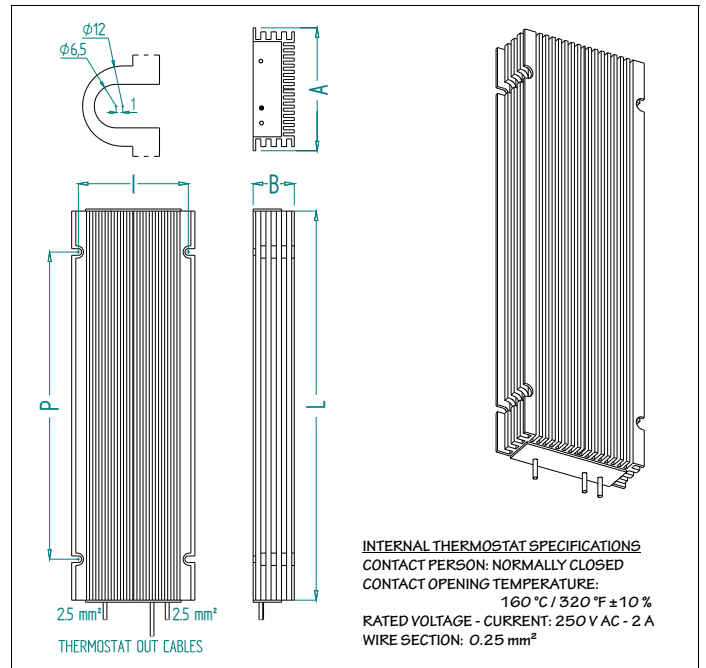

INTERNAL THERMOSTAT SPECIFICATIONS
 CONTACT PERSON: NORMALLY CLOSED
 CONTACT OPENING TEMPERATURE:
 160°C / 320°F ±10 %
 RATED VOLTAGE - CURRENT: 250V AC - 2 A
 WIRE SECTION: 0.25 mm²

	ER+TH-18/1800		ER+TH-18/2200	
Units	mm	in	mm	in
A	120	4.72	190	7.48
B	40	1.57	67	2.63
L	380	14.96	380	14.96
I	107÷112	4.21÷4.40	177÷182	6.96÷7.16
P	300	11.81	300	11.81

External resistor with external thermostat and fan

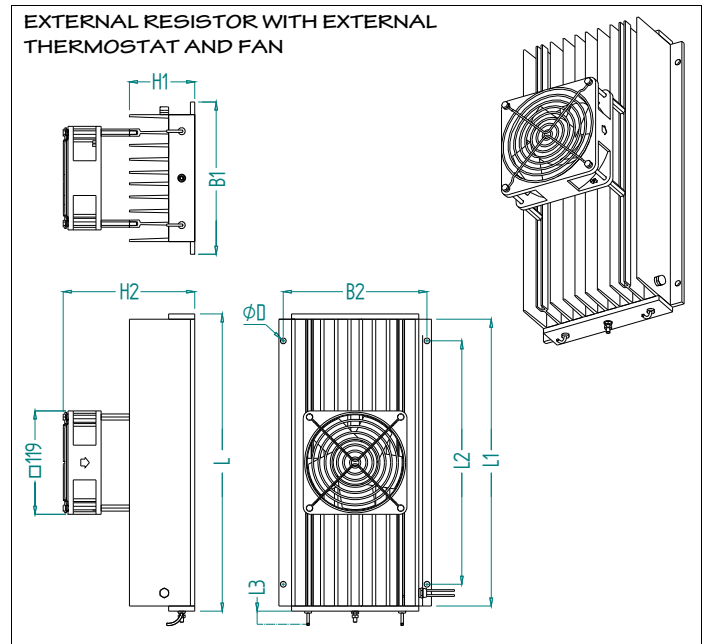

	ER+TH-18/1000+FAN		ER+TH-18/1500+FAN		ER+TH-18/2000+FAN	
Units	mm	in	mm	in	mm	in
B1	175	6.88	175	6.88	175	6.88
B2	165	6.49	165	6.49	165	6.49
H1	76	2.99	76	2.99	76	2.99
H2	154	6.06	154	6.06	154	6.06
L1	170	6.69	329	12.95	530	20.86
L2	121	4.76	280	11.02	500	19.68
L3	250	9.84	250	9.84	250	9.84
L	188	7.40	347	13.66	548	21.57
Ø D	6.5	2.55	6.5	2.55	6.5	2.55

External thermostat

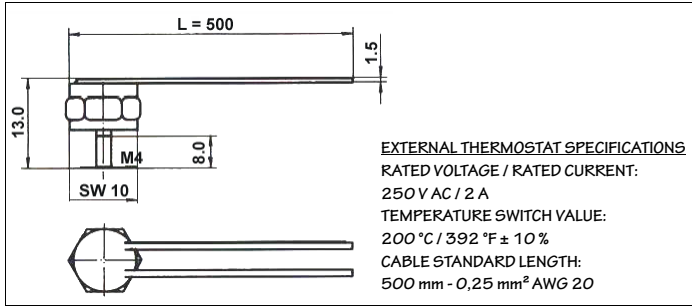

RPS CHOKES

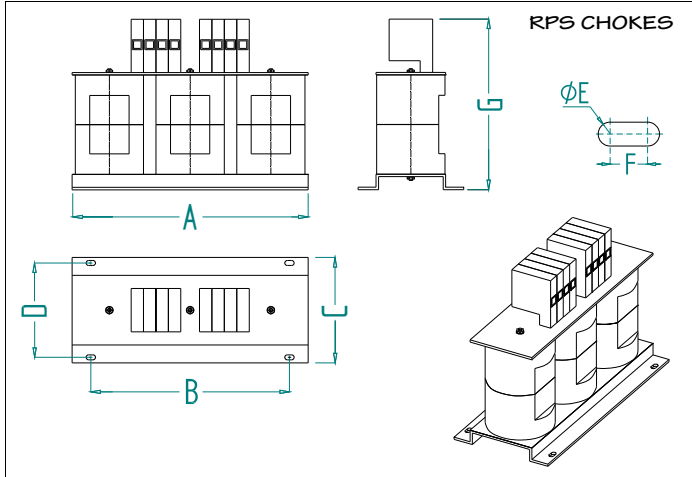

CHOKE	RPS-20		RPS-45		RPS-75-3	
Units	mm	in	mm	in	mm	in
A	330	12.99	330	12.99	380	14.96
B	175	6.88	175	6.88	235	9.25
C	136	5.35	136	5.35	152	5.98
D	150	5.90	150	5.90	170	6.69
E	8	0.31	8	0.31	9	0.35
F	15	0.59	15	0.59	18	0.70
G	162	6.37	228	8.97	271	10.66

XPS CHOKES

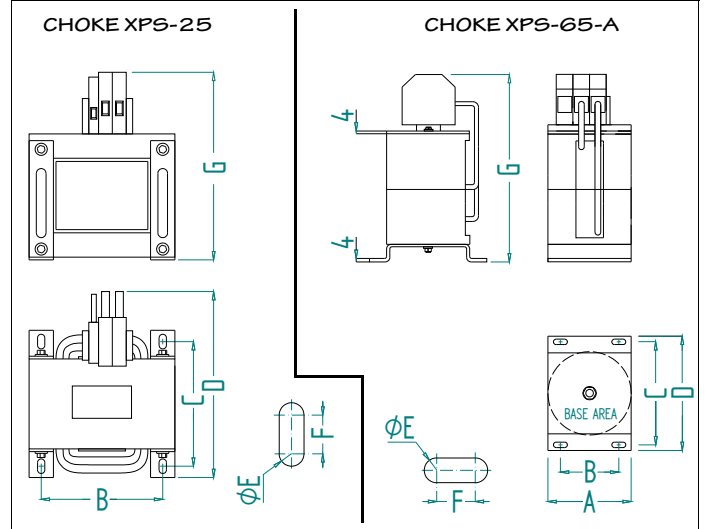

CHOKE	XPS-25		XPS-65-A	
Units	mm	in	mm	in
A	-	-	120	4.72
B	105	4.13	85	3.34
C	115	4.52	152	5.98
D	180	7.08	170	6.69
E	8	0.35	9	0.35
F	10	0.39	9	0.35
G	165	6.49	266	10.47

MODULAR DRIVE CONNECTORS

This is a sample diagram with all connecting options.

SPD MODULAR DRIVE WITH FM7 MOTOR CONNECTION

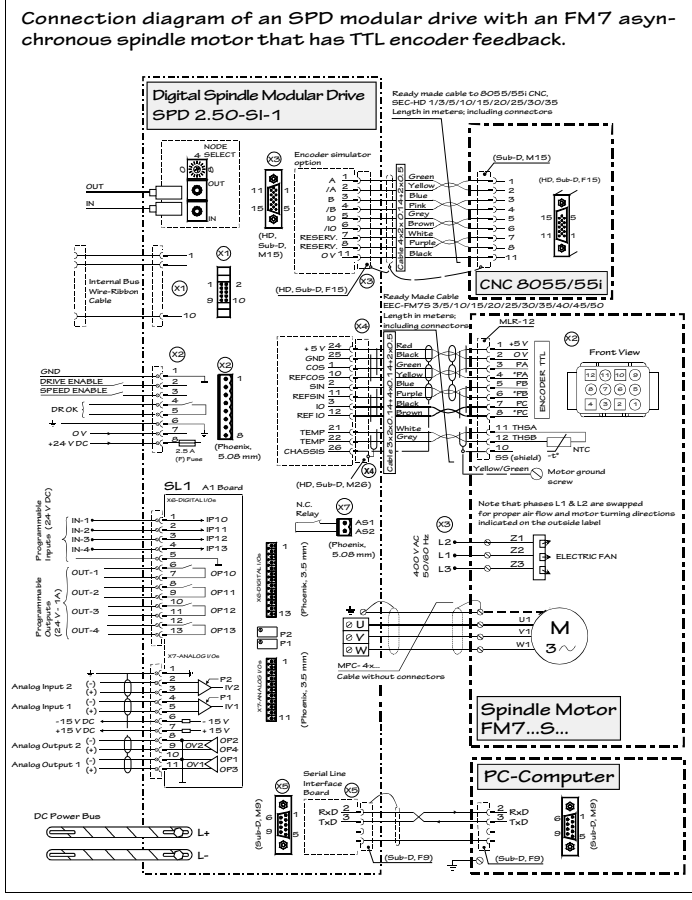

AXD MODULAR DRIVE WITH FKM2/4/6 MOTOR CONNECTION

This diagram represents the connection possibility for an FKM2/4/6 motor with encoder feedback. The rest of the connectors are shown on the previous example.

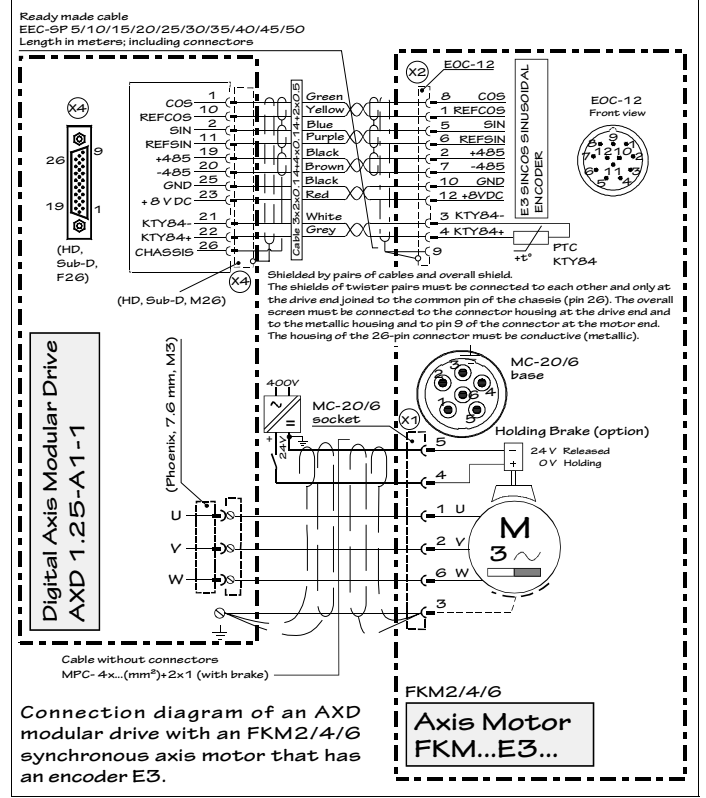

AXD MODULAR DRIVE WITH FXM MOTOR CONNECTION

This diagram represents the connection possibility for an FXM motor with encoder feedback. The rest of the connectors are shown on the previous example.

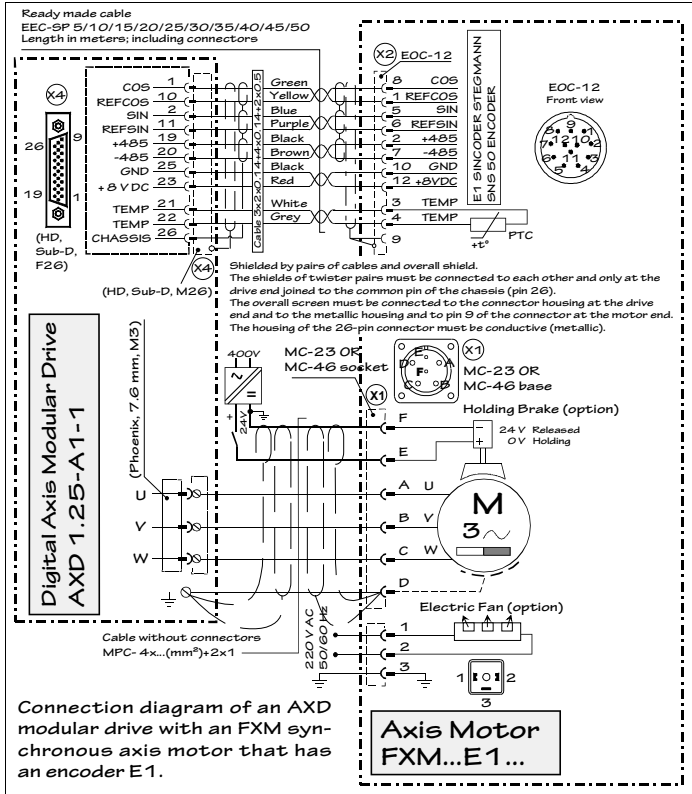

AXD MODULAR DRIVE WITH FKM8/9 MOTOR CONNECTION

This diagram represents the connection possibility for an FKM8/9 motor with encoder feedback. The rest of the connectors are shown on the previous example.

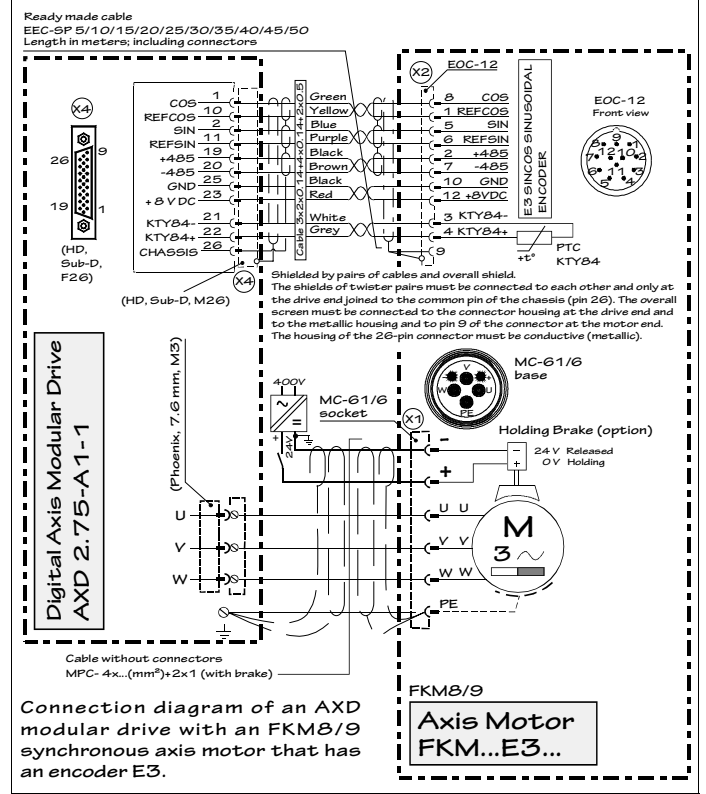

CONNECTORS AT SLOTS SL1 AND SL2

Card A1

The A1 Card must always be in slot SL1.

X6-DIGITAL I/Os, digital inputs and outputs

It offers 4 digital inputs and 4 digital outputs, all of them fully programmable. The digital inputs are optocoupled and referred to a common point (pin 5). The digital outputs are contact type and also optocoupled.

Each input and output is associated with a parameter. The user may assign to these parameters, internal boolean type variables that may be used to show the system status via electrical contacts.

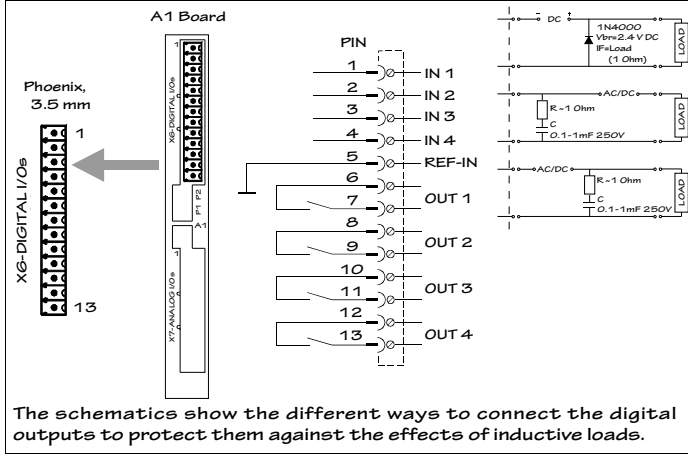

Digital inputs characteristics

Nominal voltage (maximum)	24 V DC (36 V DC)
Turn on/off input voltage	18 V DC (5 V DC)
Typical consumption (maximum)	5 mA (7 mA)

Digital outputs characteristics

Maximum voltage	250 V
Maximum load current (peak)	150 mA (500 mA)
Maximum internal resistance	24 Ω
Galvanic isolation voltage	3750 V (1 min)

X7-ANALOG I/Os, analog inputs and outputs

It offers 2 inputs and 2 outputs, all of them fully programmable. Each input and output is associated with a parameter.

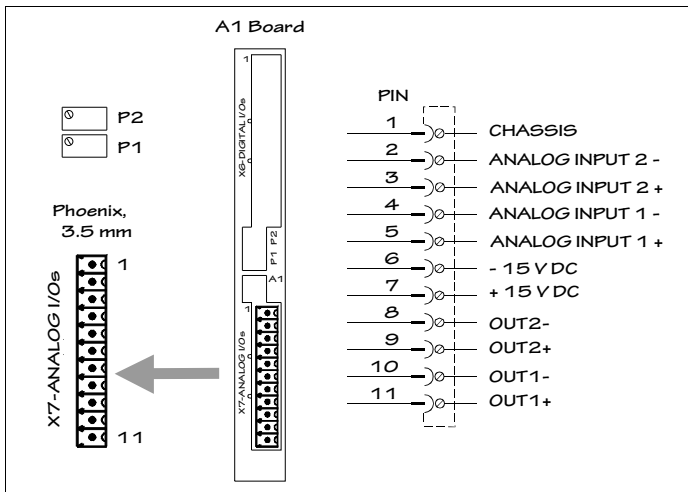

Analog inputs characteristics

Resolution	1.22 mV	
Input voltage range	± 10 V DC	
Input overvoltage	Continuous mode	80 V DC
	Transients	250 V DC
Input impedance	With respect to GND	40 kΩ
	Between both inputs	80 kΩ
Voltage in common mode	20 V DC	

Analog outputs characteristics

Resolution	4.88 mV
Voltage range	± 10 V DC
Maximum current	± 15 mA
Impedance (respect to GND)	112 Ω

Cards 8DI-16DO and 16DI-8DO

These cards may be located in slot SL1 and/or SL2.

08DI-16DO offers to the user 8 digital inputs and 16 outputs.

16DI-08DO offers to the user 16 digital inputs and 8 outputs.

X8-DIG.INs, X11-DIG.INs, X12-DIG.INs, digital inputs

They offer 8 fully programmable digital inputs.

The digital inputs are optocoupled and referred to a common point (pin 1) and they admit digital signals at 24 V DC. Each input is associated with a PLC resource.

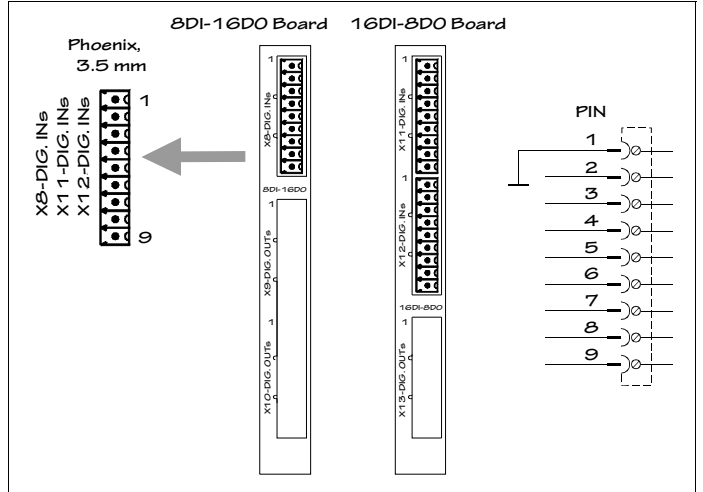

Digital inputs characteristics configured at 24 V DC

Nominal voltage (maximum)	24 V DC (40 V DC)
ON/OFF voltage	12 V DC (6 V DC)
Typical consumption (maximum)	5 mA (7 mA)

X9-DIG.OUTs, X10-DIG.OUTs, X12-DIG.OUTs. digital outputs

They offer 8 fully programmable digital outputs.

These outputs are optocoupled and of the contact type referred to a common point (pin 1).

Each output is associated with a PLC resource.

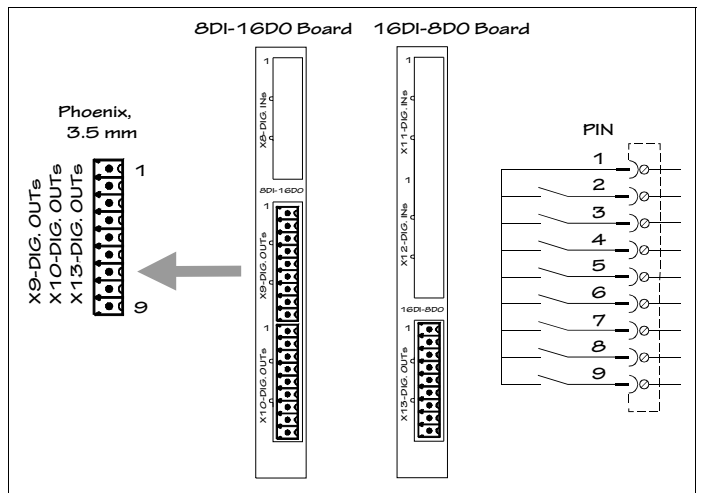

Digital outputs characteristics

Maximum voltage	250 V
Maximum load current	150 mA
Current autosupply	200 mA
Maximum internal resistance	20 Ω
Galvanic isolation voltage	3750 V (1 min)

CONNECTING THE MOTOR FEEDBACK TO THE DRIVE

Use the cable with connectors supplied by FAGOR to lead the motor feedback to connector X4 of the drive module. The motor feedback is an encoder.



INFORMATION. Note that both type I and II mentioned next are the same. Their only difference is the color of the wires because they are from different manufacturers. When referring to the cable hose, it means the cable without connector shown on the connection diagrams. The user must verify which one matches his cable by looking at these diagrams.

ENCODER CABLES WITH FXM/FKM SYNCHRONOUS SERVO MOTORS

EEC-SP, encoder connection. I type

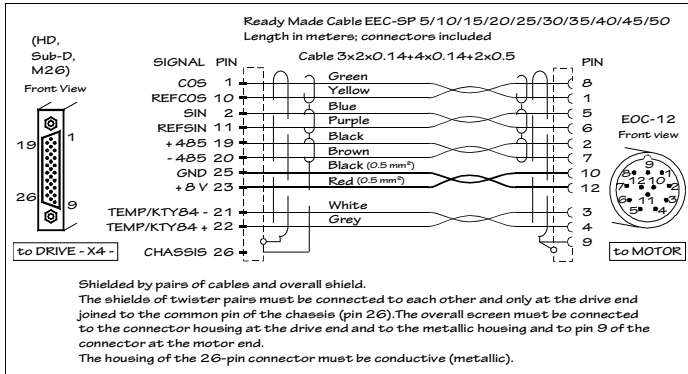

EEC-SP, encoder connection. II type

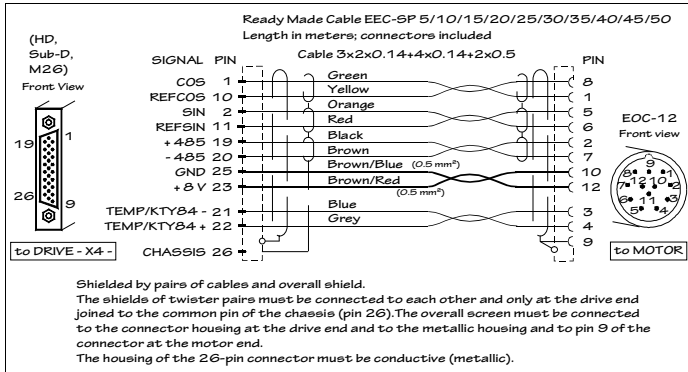

ENCODER CABLES WITH FM7 ASYNCHRONOUS MOTORS

EEC-FM7, standard TTL encoder connection

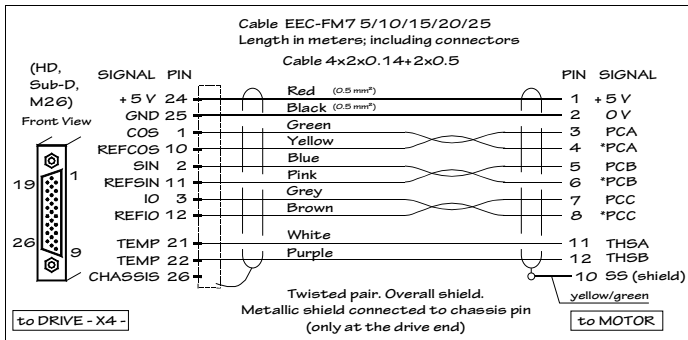

EEC-FM7S, standard TTL encoder connection. I type

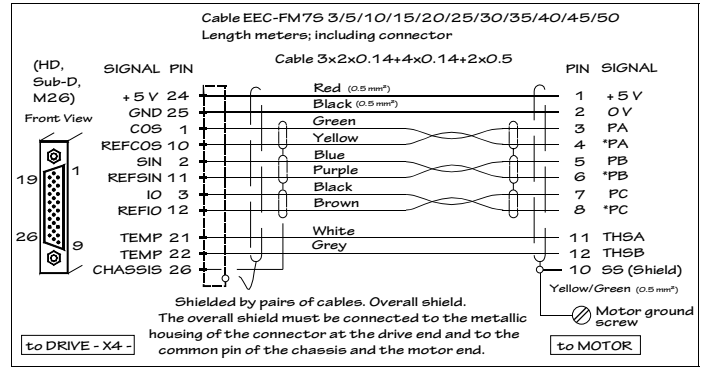

EEC-FM7S, standard TTL encoder connection. II type

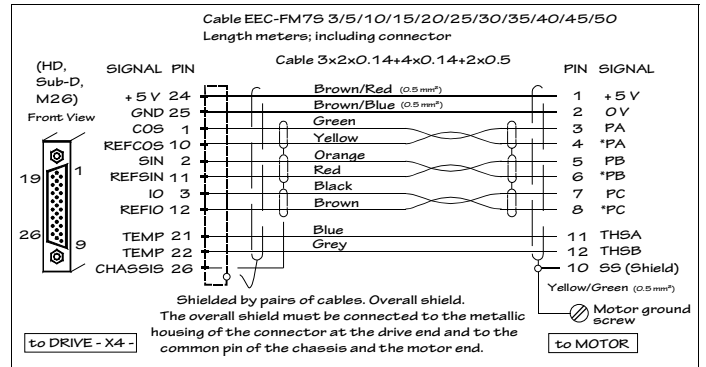

EEC-FM7CS, Sincos encoder of the C axis connection. I type

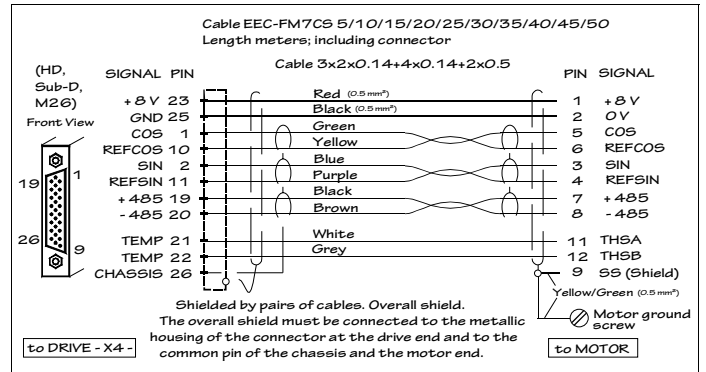

EEC-FM7CS, Sincos encoder of the C axis connection. II type

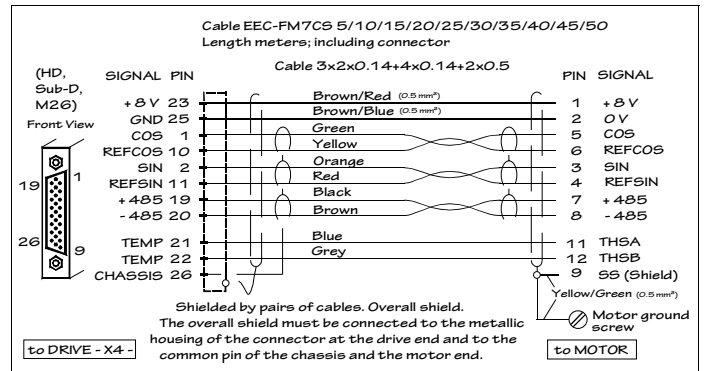

CONTROL AND COMMUNICATION SIGNALS

Connect the encoder simulator signal to the CNC.

SEC-HD, encoder simulator connection

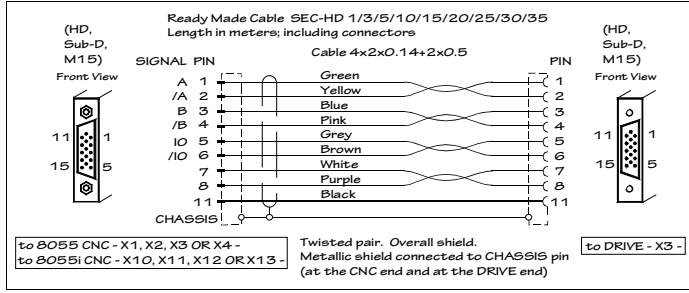

EC-□ PD, direct feedback with external incremental linear or rotary encoder (1 Vpp or differential TTL)

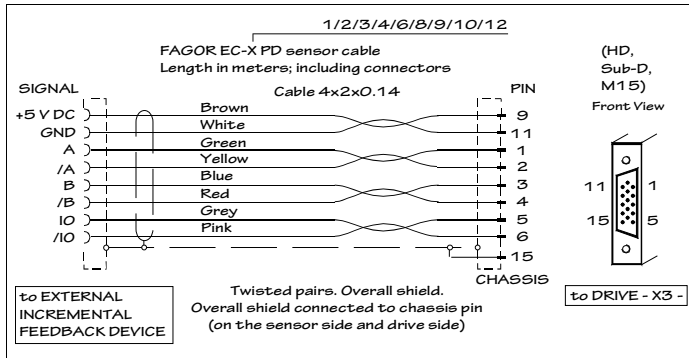

EC-□ B-D, direct feedback with external absolute linear encoder (1 Vpp or differential TTL)

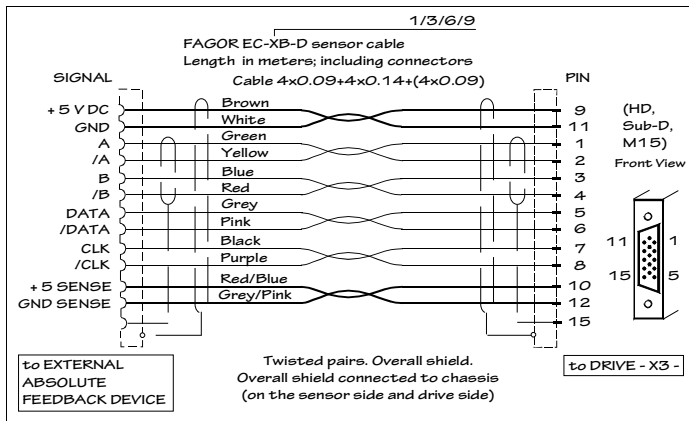

Direct feedback Stegmann sinusoidal encoder

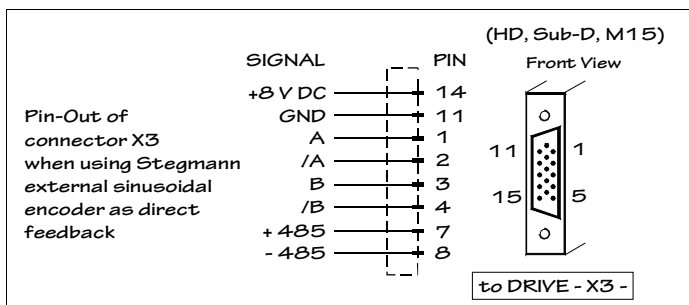

RS-232 SERIAL LINE. X5 CONNECTOR

RS-232 serial line cable to a PC

To transfer the parameter table and setup the system, the drive must be connected to a PC-Compatible computer through a serial line RS-232.

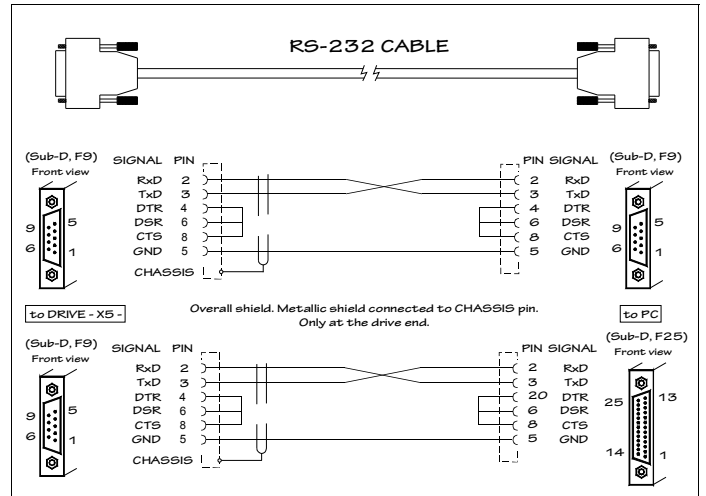

RS232/RS422 BE adapter

Some connections will mention the "RS232/RS422 BE" adapter, thus being necessary to describe it and its pinout at both ends.

Note. Remember that the user is free to use it or not. However, using it would make the connection a lot easier.

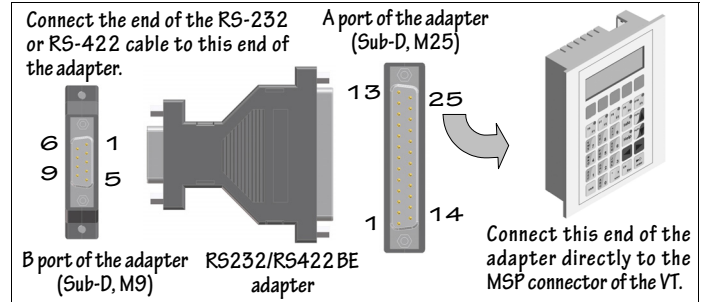

RS-232 serial line between PC and VT (without adapter)

The VT-PC connection is essential for transferring the communication driver and the project.

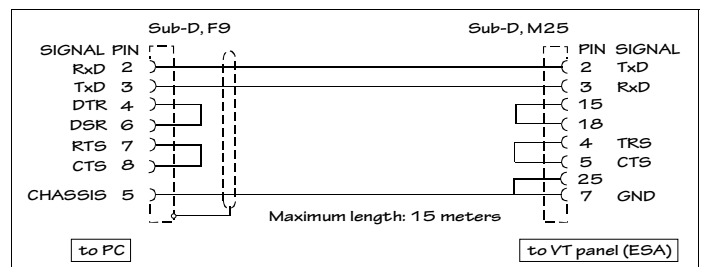
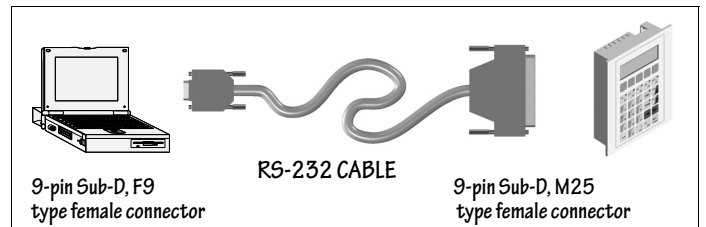

RS-232 serial line between PC and VT (with adapter)

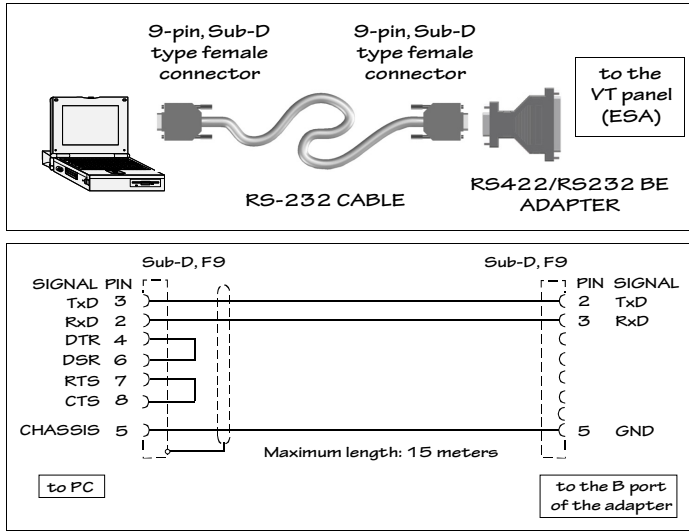

RS-232 serial line between VT and Drive

It will then be possible to manage and control the various process applications from the VT.

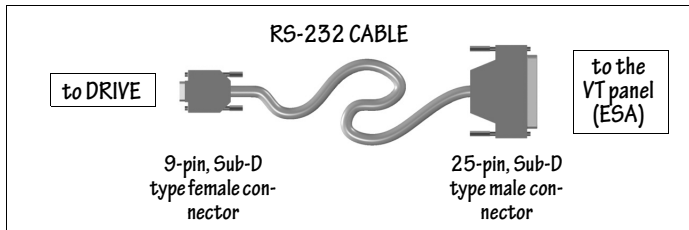

Note. The RS232/RS422 BE adapter is not required in any case.

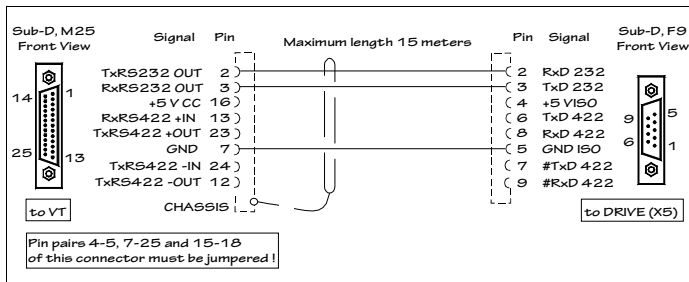

RS-422 SERIAL LINE. X6 CONNECTOR

Note. In this section, when mentioning drives, it means **only** the MMC models of the FAGOR catalog. This connection must be used when using ModBus communications protocol between an ESA VT panel and several MMC modules.

Once the project has been transferred from the PC to the VT, the VT may now be connected with several drives. This connection may be made either by connecting directly as described next or through the adapter RS232/RS422 BE that will make the connection a lot easier for the user. In either case, communication must be established through the MSP serial port of the VT (port A when using the adapter) and the RS-232/RS-422 serial port (B port when using the adapter) of each drive.

VT and MMC connection through RS-422 cable (without adapter)

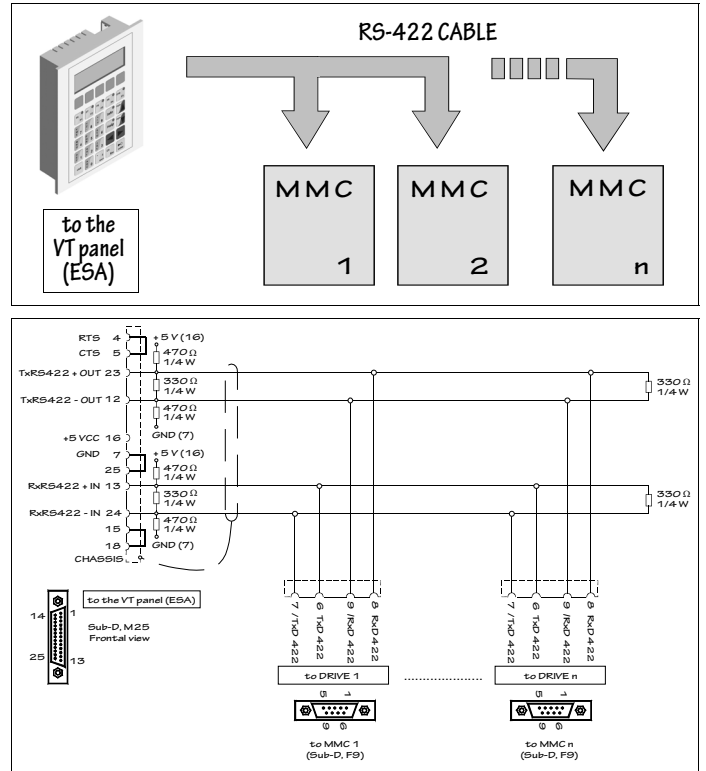

VT and MMC connection through RS-422 cable (with adapter)

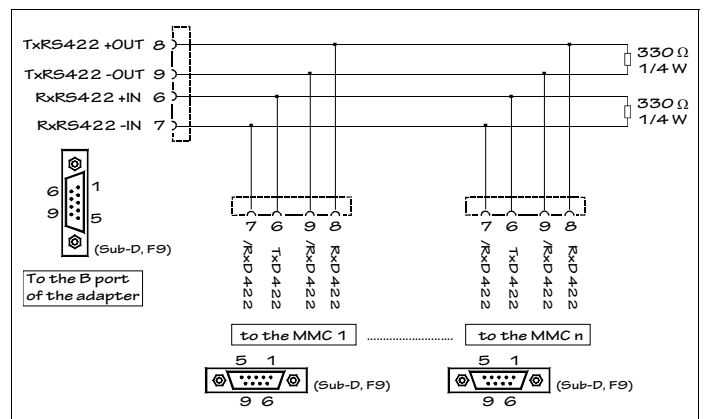
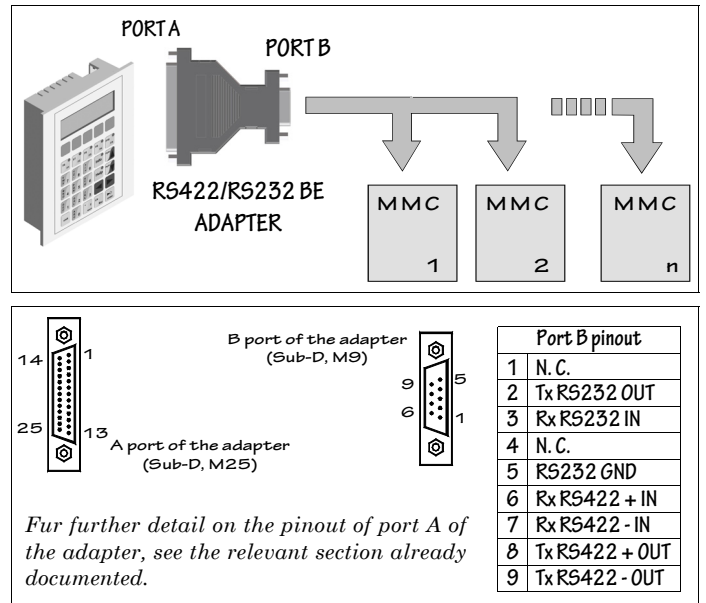

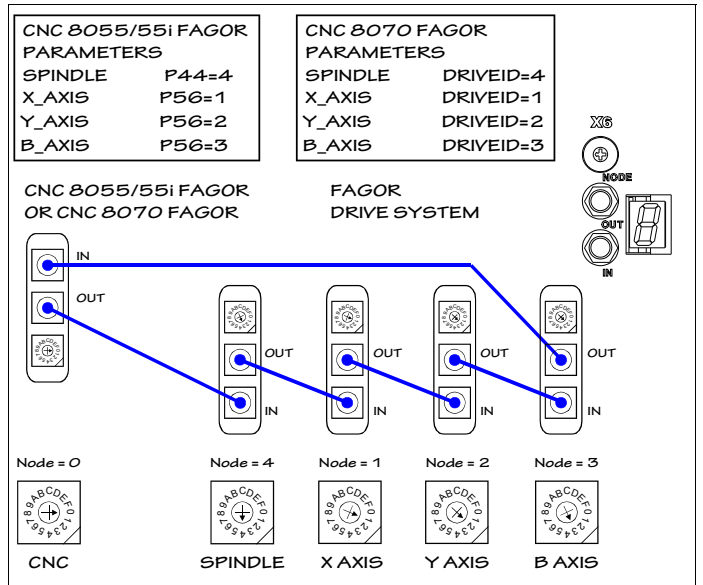
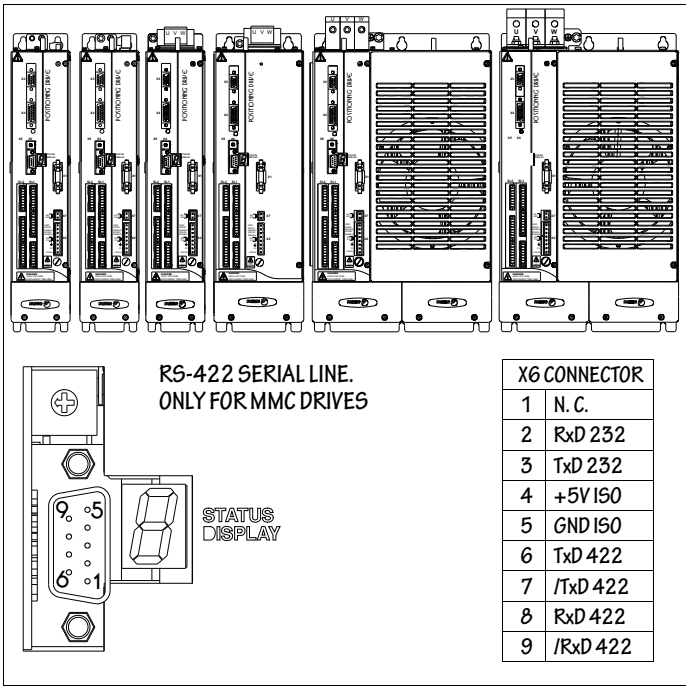

Note. If the machine has two separate DDS system (each with its own power supply) and a single CNC, the same ring must interconnect all the drives of the machine.



INFORMATION. Any MMC drive may be configured with an RS-232 serial line and SERCOS or CAN interface or with an RS-422 serial line.



WARNING. The bending radius of the fiber optic cable must be more than 30 mm (SFO-x & SFO-FLEX-x) or 60 mm (SFO-V-FLEX-x).

Transmission speed selection

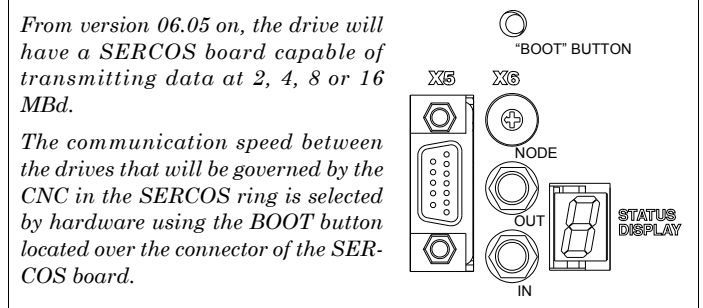

Note. This board will not be compatible with software versions older than 06.05.

SERCOS RING CONNECTION

Interconnection

Connect in the SERCOS ring all the drives that will be governed by the CNC.

- With each fiber optic line, connect the OUT terminal of the first drive with the IN terminal of the next adjacent drive.
- Repeat this procedure with the second drive and so on up to the last drive.
- Connect the OUT terminal of the last drive with the IN terminal of the CNC.
- Connect the IN terminal of the first drive with the OUT terminal of the CNC.

When all these connections have been made, the ring will be closed.

Note. Remember that each drive has a fiber optic line to connect it to the adjacent module. FAGOR supplies the rest of the optical fiber upon request.

FAGOR supplies the fiber optic cable with its terminals protected with a hood.

Remove the terminal protecting hood before connecting the cable. Either to remove the terminal protecting hood or to connect and disconnect the cable, the cable must always be held by the terminal, never pull at the cable because it could get damaged.

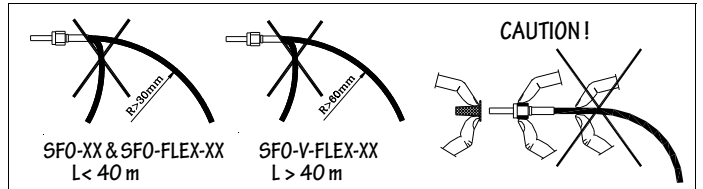

CAN BUS CONNECTION

Interconnection

Connect in the CAN field bus all the drives that will be governed by the CNC.

- Use the CAN cable to connect the first drive to the adjacent one (it will be the second drive) through their X6 connectors.
- Repeat this procedure with the second drive and its adjacent drive and so on up to the last drive.
- Use a CAN cable to connect the X6 connector of the first drive to the CAN connector of the CNC model being used.

Note. Note that the CAN cable is supplied without connectors! Before connecting it, put the cable and connectors together as indicated in figure.

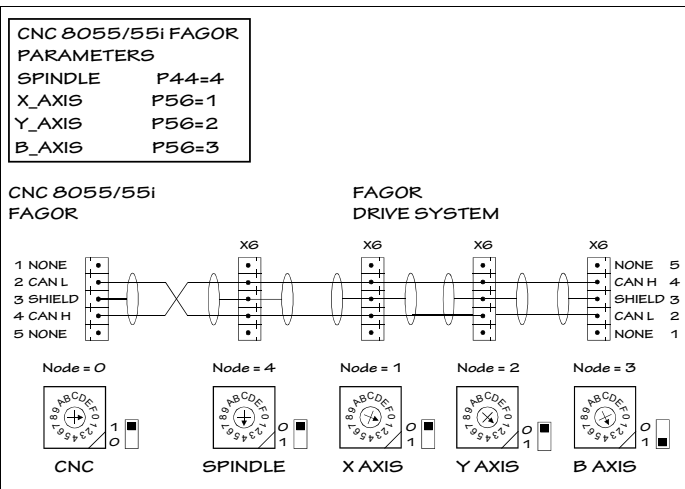
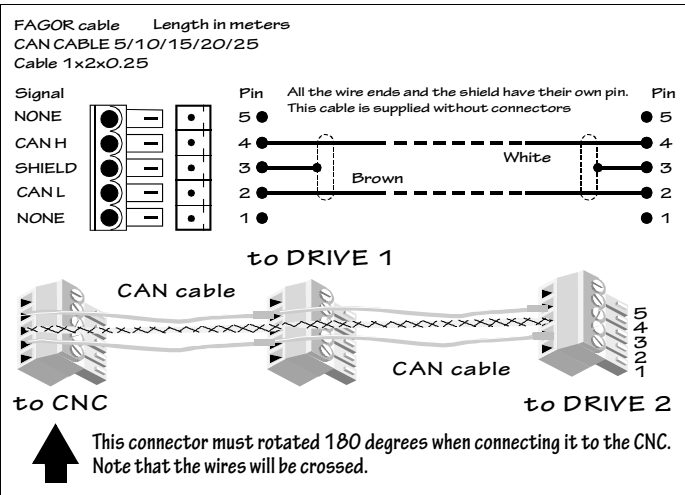

Note. No more than six drive modules (axes+spindles) can be connected in the CAN bus.

WARNING. The bending radius of the CAN cable must always be more than 50 mm.

Terminating resistor

After connecting the modules, make sure that the elements at each end connected to the bus have the terminating resistor activated; i.e. the terminal resistor switch (under the CAN connector) of the last drive (usually the one farthest away from the CNC) is set to 1 (switch down) and the rest of the drives with the terminal resistor set to 0 (switch up). The CNC (or the ESA panel), located at the end of the bus always has this resistor activated.

Transmission speed selection

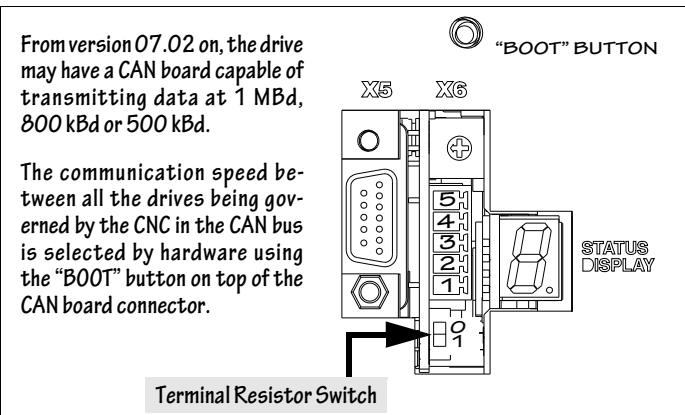

ELECTRICAL INSTALLATION

MOUNTING CONDITIONS

- The DDS system must be mounted vertically in the electrical cabinet with the power connectors on top.
- The equipment should be installed so as to leave at least 80 mm (3.15 in) above and below it.
- The temperature around the equipment should always be under 55°C /131°F. Vibration should be avoided.
- When applying external cooling to the system, make sure that water condensation does not fall on the equipment.
- Never install the DDS system in places where there are corrosive gases.
- ER+TH-x/x and ER+TH-18/x+FAN modules should be mounted away from the rest of the heat sensitive modules and materials. We recommend the upright position with the cables down (ideal case), but the horizontal position is also acceptable (although with lower dissipation). Never position it in the upright with the cables up. Remember that the RM-15 only guarantees a sealing protection of IP 20.

ELECTRICAL INTER-CONNECTION OF THE DRIVE SYSTEM

See electrical drawings.

- Connect the ground connection
Tightening torque 2.3 ÷ 2.8 Nm
- Connect the internal bus X1
- For connecting an external Ballast resistor, RM-15 (discontinued), ER+TH-x/x or ER+TH-18/x+FAN
Remove the wire joining Ri and L+ and connect the module between Re and L+ terminals. Never connect an external resistor in parallel with the internal Ballast resistor.

EXTERNAL BALLAST RESISTOR

How to install an external Ballast resistor with internal thermostat and with no fan

WARNING. On top of the ER+TH modules, the air temperature can reach values over 120°C (248°F). Therefore, the resistor should be mounted away from the rest of the modules or even outside the electrical cabinet, always vertically and away from cables and other temperature sensitive material.

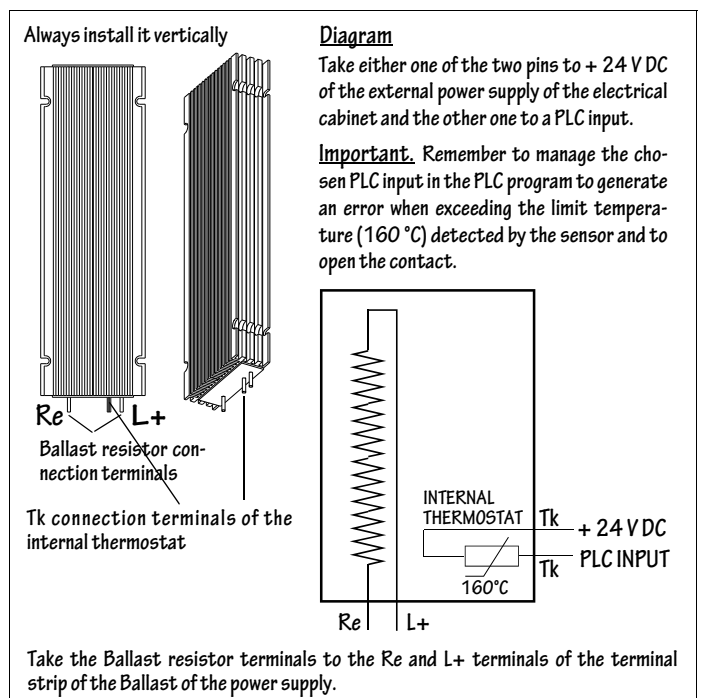

How to install an external Ballast resistor with an external thermostat and with no fan



WARNING. On top of the ER+TH modules, the air temperature can reach values over 120°C (248°F). Therefore, the resistor should be mounted away from the rest of the modules or even outside the electrical cabinet, always vertically and away from cables and other temperature sensitive material.

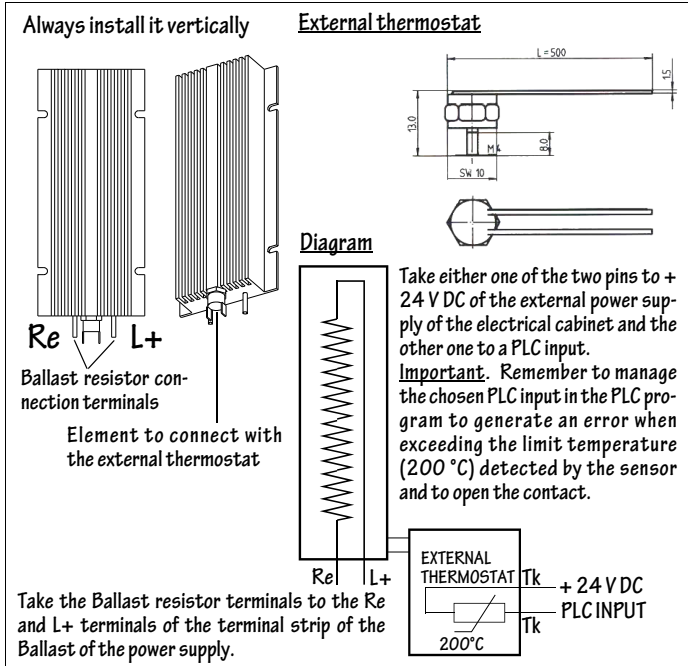

How to install an external Ballast resistor with internal thermostat and fan



WARNING. Therefore, the resistor should be mounted away from the rest of the modules or even outside the electrical cabinet, always vertically and away from cables and other temperature sensitive material.

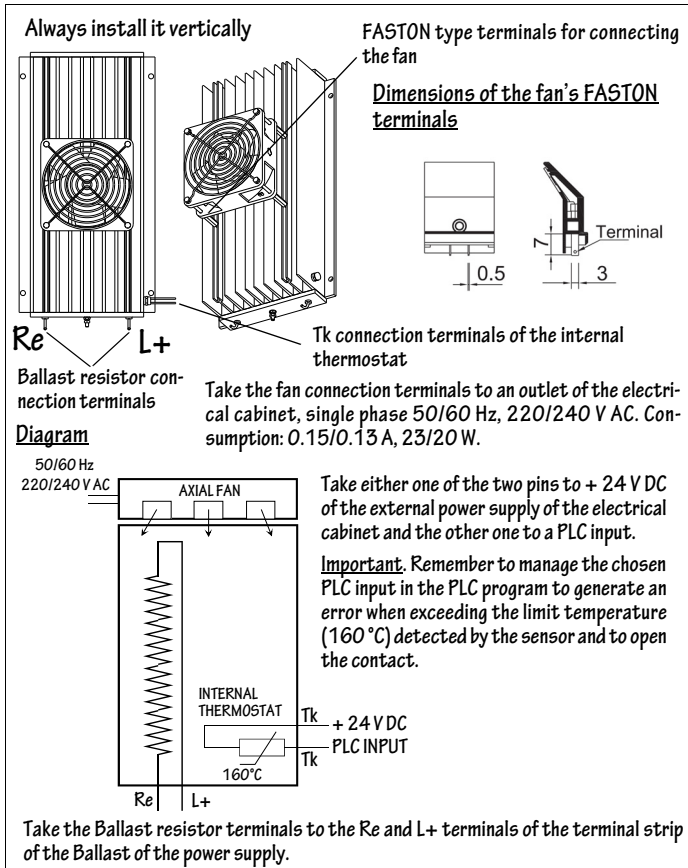

How to install two external Ballast resistor in parallel. Diagrams

Always install both resistors vertically

For two resistors in parallel with fan and internal thermostat

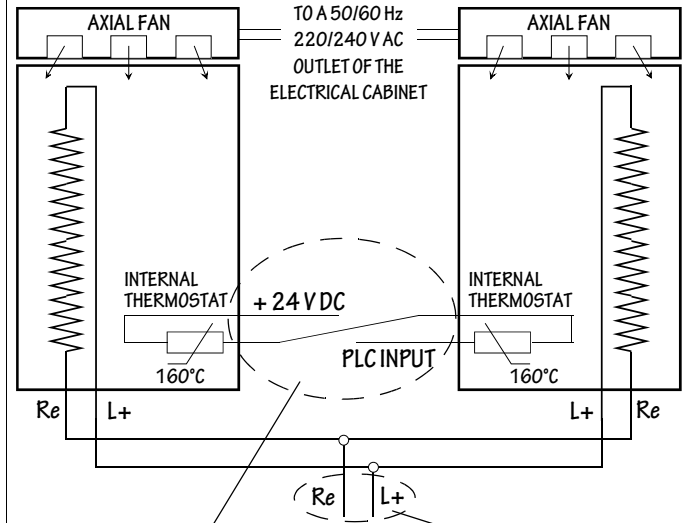

Take the terminal labeled + 24 V DC to an external 24 V DC power supply of the electrical cabinet and the other one labeled PLC INPUT to a PLC input. **Important.** Remember to manage the chosen PLC input in the PLC program to generate an error when exceeding the limit temperature (160 °C) detected by the sensor and to open the contact.

Take the indicated terminals to the Re and L+ terminals of the terminal strip of the Ballast of the power supply (only PS-65A or XPS-65).

For two resistors in parallel with an internal thermostat and no fan

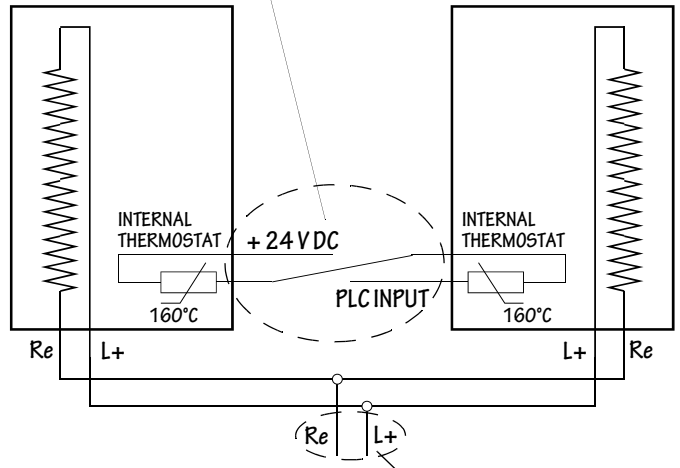

Take the indicated terminals to the Re and L+ terminals of the terminal strip of the Ballast of the power supply (only PS-65A or XPS-65).

MOTOR DRIVE CONNECTIONS

Power connections

Connect the power cable MPC. Connect terminal U of the drive with the terminal corresponding to the U phase of the motor. Same as terminals V-V, W-W, and PE-PE terminal of the drive and NOT to that of the motor.

Feedback connections

Motor feedback connection

Connect the encoder cable (EEC-SP, EEC-FM7, EEC-FM7S, EEC-FM7CS), accordingly to take the feedback from the motor to the drive. It is connected directly through the feedback cable between the feedback connector of the motor and connector X4 of the drive module as long as the isolation level required by FAGOR is guaranteed between the motor temperature sensor and the power circuit of the drive.



WARNING. FAGOR uses isolation systems between the temperature sensors and the winding of their motors ensuring long life to the motor-drive system regardless of wiring lengths. When installing non-FAGOR motors, since it cannot be guaranteed that the existing isolation will comply with FAGOR standards, we recommend installing the isolation adapter TSIA-1.

Note that installing the temperature sensor isolation adapter TSIA-1 means getting galvanic isolation between the temperature sensor of the motor and the drive itself.



INFORMATION. Note that the isolation adapter TSIA-1 does not check the encoder signals or the temperature sensor of the motor. It only provides galvanic isolation of the temperature sensor.

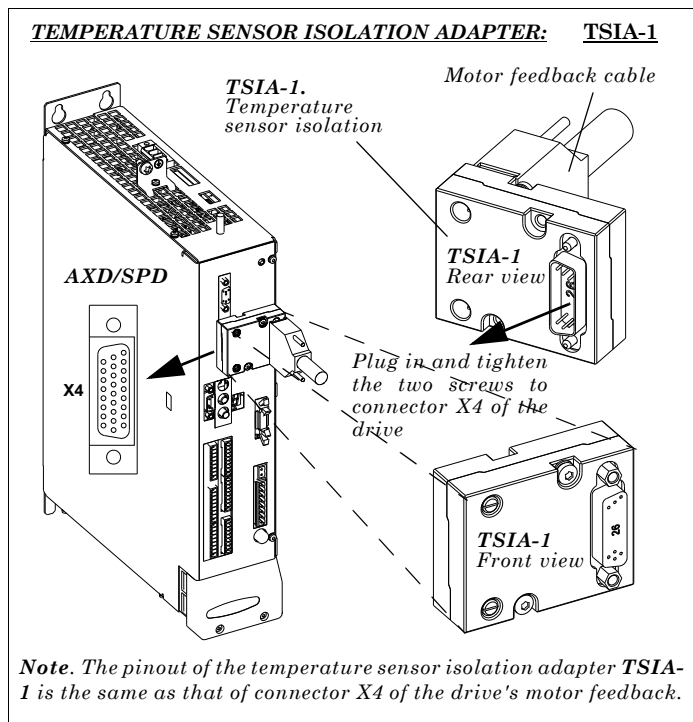

Direct feedback connection or encoder simulator connection

Connect the SEC-HD cable to take the encoder simulation from the drive (X3 connector) to the CNC, or connect the EC-□ PD or EC-□B-D cable to take the feedback from the sensor to the drive (X3 connector).

CABLING OF THE SYSTEM TO MAINS

Mains connection

The FAGOR DDS system is designed to be connected to TN type three-phase mains with values within the voltage range between 400 V AC (-10 %) and 460 V AC (+10 %) and a mains frequency of 50/60 Hz.

Connecting it to a different voltage range requires the use of transformers or autotransformers.

The connection may vary depending on the type of mains and Electromagnetic Compatibility required by the machine.



MANDATORY. Never connect other components (motors, inductive components, etc.) in parallel with the drive system. They may cause the system to perform poorly when stopping the machine. The equipment to be connected together with the DDS system must be powered through a second contactor or through auxiliary contacts of the drive's contactor.



INFORMATION. The mains filter may be installed either before or after the power switch - KM1.

Certain mandatory protection devices must be added to the mains lines. Others are optional.

Note. RST, Classic nomenclature; L1L2L3, current nomenclature

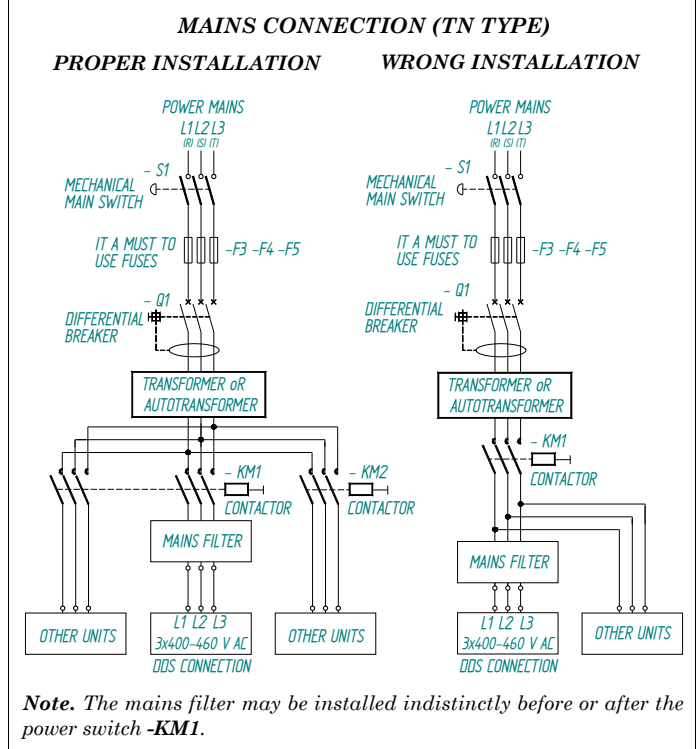

Protection fuses

The DDS system does not include the fuses.



WARNING. The protect the DDS system fuses must be included on the lines coming from mains.



WARNING. Using other types of protection instead of fuses (e.g.: magneto-thermal switches) does not ensure the proper protection of the unit.

MANUFACT.	PS-25B4 XPS-25 RPS-20	PS-65A XPS-65 RPS-45	RPS-75
BUSSMANN	FWH45B	RF00-125A	-
	XL50F-45A	XL50F-125A	-
	RF-000-40A	RF-000-125A	-
	40FE	100FE	160FEE (5700)
	170M2611	170M1318	170M1319
GOULD	A00-66C5D8	A00-66C125D8	-
	A00-66C5D1	A00-66C125D1	-
FERRAZ	6.9 gRB 00 D08L 040	6.9 gRB 00 D08L 125	6.9 gRB 00 D08L 160
	6.6 gRB 000 D08/040	6.6 gRB 000 D08/100	6.6 gRB 000 D08/160
SIBA	20 189 20- 50A	20 189 20- 125A	20 189 20-160A
WICKMAN	45FEE	140FEE	-
SIEMENS	3NE8 003	3NE8 021	3NC8423-3
LITTELFUSE	-	L70S125	L70S150



WARNING. Actually, IGBT components cannot be protected with fuses. Therefore, when using RPS-75 power supplies, the protection does not prevent the module from breaking down. Using them minimizes the number of components that may be damaged as a result of a possible malfunction.

Differential breaker

On a DDS system, fault DC current, practically flat, may come up besides the AC currents and pulsating DC currents. This requires the use of a differential breaker. This switch must be a B type universal breaker of selective disconnection.



INFORMATION. It is not recommended to use differential breakers sensitive to pulsating currents and, overall, general purpose differential breakers. In this cases, undesired stops might occur due to the high sensitivity of those devices to pulsating currents.



MANDATORY. Never use AC type differential breakers.

As an alternative, "A type" differential signals may be used with selective shut-off. They are more economical than the "B type" and usually valid for DDS systems with a FAGOR filter. The shut-off current must be equal or greater than 500 mA and with selective switch-off.

Isolating transformer or auto-transformer

When the mains voltage must be isolated or adapted to the levels required by the DDS system, it may be connected through an isolating transformer or an auto-transformer. This element will also help reduce the amount of harmonics on the line although it will not guarantee the compliance with the EC regulation.



INFORMATION. When having a mains perfectly referred to ground, autotransformers may be used to adapt the mains voltage. However, if mains is not referred to ground, an isolating transformer must be used in order to avoid possible dangerous voltage surges on any phase with respect to ground that could damage the equipment. In this situation, the secondary must have a star configuration with access to the middle point. This middle point of the secondary must be connected to ground or the neuter of mains.



INFORMATION. On systems with an XPS power supply, the inductance of the transformer must be very low and negligible against the inductive value of the choke XPS.



MANDATORY. When using transformers or auto-transformers, the main contactor must be connected between them and the DDS system, never on the input line of the transformer or autotransformer.



MANDATORY. On machines where the DDS system includes XPS power supplies, it is essential to properly size the transformer or auto-transformer. The rated (nominal) power of the auto-transformer is the result from the formula $P_n = 1.4 \cdot P_{max}$, where P_{max} is the maximum braking power of the system. This power may be, in general, close to the power in the S6 duty cycle of the asynchronous spindle motor.

Hence it is possible to apply simultaneity factors and decrease the power required by the transformer or auto-transformer. It is also **highly recommended** to use auto-transformers instead of isolating transformers when only an adaptation of the working voltages is required.



MANDATORY. For systems with XPS power supplies, install isolating transformers **ONLY** when the type of mains so requires.

Remember that if the isolating transformer is installed, depending on its power and impedance, it may be required to install a second choke in series with the one that must be installed with XPS power supplies.



WARNING. Not complying with the previous indications could cause the DDS system to perform poorly.



INFORMATION. When in a system with XPS power supply, the pulses of the drives are activated, a very low frequency blinking (flashing) may be observed on the amber LED of energy regeneration to mains. THIS BEHAVIOR IS NORMAL and does NOT indicate that the system is not working properly. Deactivating the pulses, the LED will stop blinking.

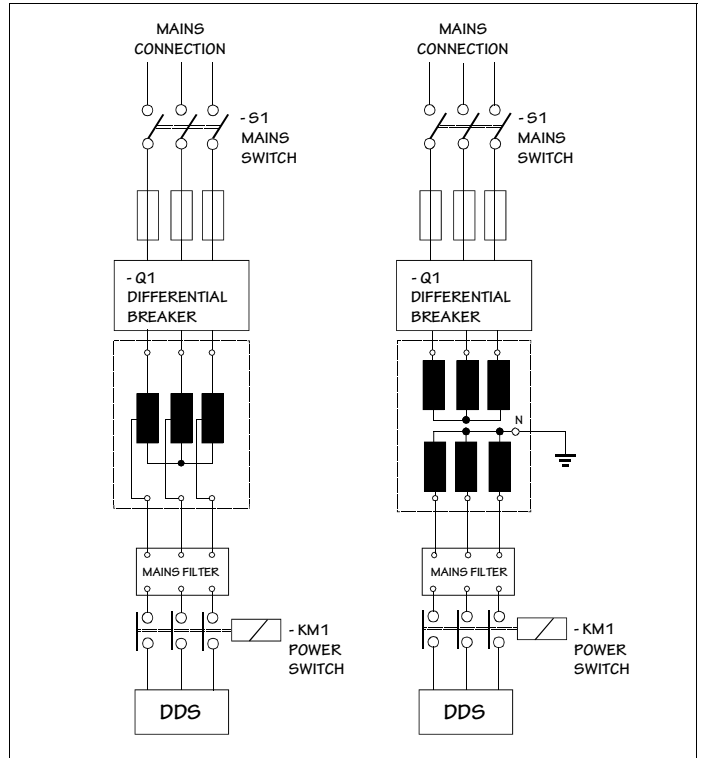

DISTRIBUTION DIAGRAMS

The distribution diagram being used must be taken into consideration in order to determine the characteristics of the protection means against electrical shocks, in case of failure (indirect contacts) and against over-current, as well as the specifications of the devices in charge of such functions. The distribution diagrams are established according to the ground connections of the distribution network or of mains, on one hand, and the of the grounds of the receiving installation on the other.

Depending on the electric energy distribution network, there are three types of diagrams: TN, TT and IT.

Note that the diagrams provided here do not show the main contactor - **KM1** that must be connected between the transformer or auto-transformer and the DDS system.

TN diagram

Distribution diagram that has a point directly connected to ground and the conductive parts of the installation are connected to this point through ground protection conductors. This type of mains admits loads between one or several phases and the neuter.

There are three kinds of TN diagrams depending on the relative position of the neuter wire (N) and the protection wire (PE):

- ❑ **TN-S diagram** where the neuter wire (N) and the protection wire (PE) are different in the entire diagram.
- ❑ **TN-C-S diagram** where the neuter and protection functions are combined in a single wire (PEN) in part of the diagram.
- ❑ **TN-C diagram** where the neuter and protection functions are combined in a single wire (PEN) in the entire diagram.



INFORMATION. The DDS system may be connected directly, through a transformer or auto-transformer in mains with a TN type distribution diagram.

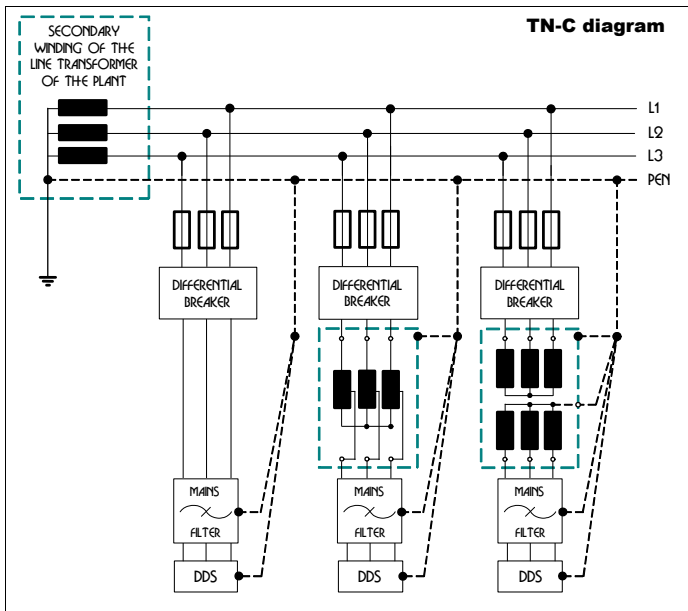

TT diagram

Distribution diagram that has a point directly connected to ground and the conductive parts of the installation are connected to a ground point independently from the ground electrode of the power supply system.

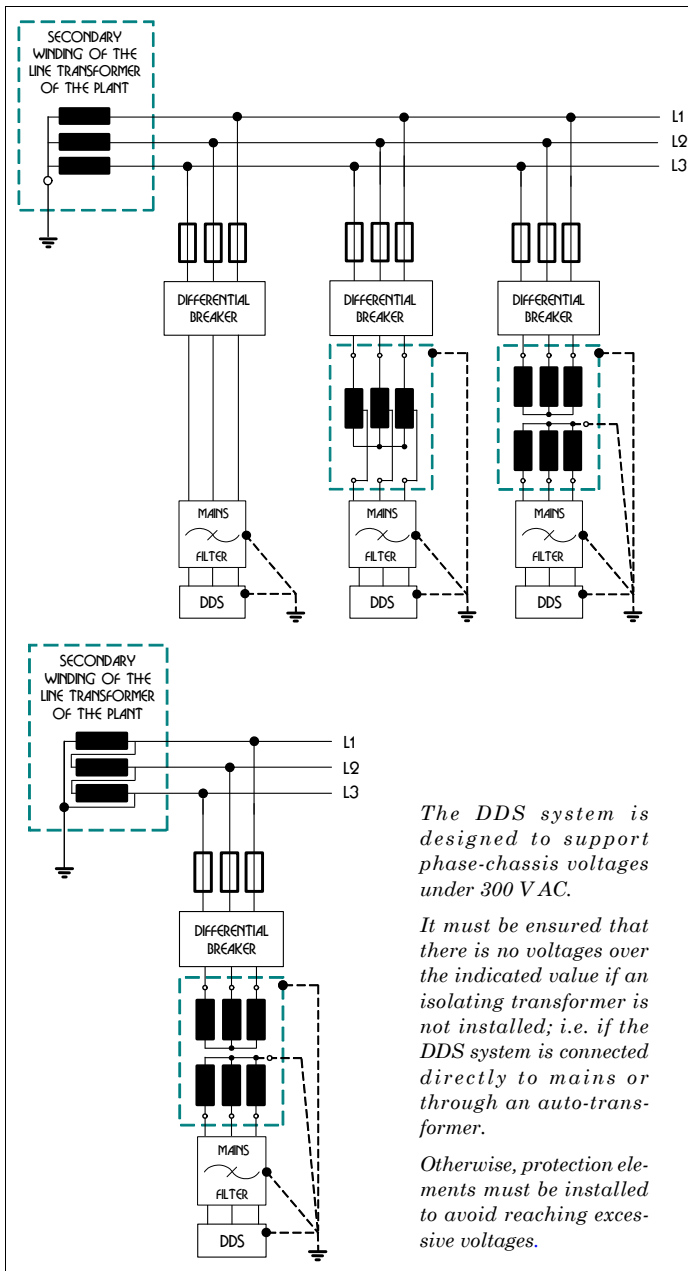

MANDATORY. 'Corner grounded' type TT mains require installing an isolating transformer.

IT diagram

Distribution diagram that has no direct connection to ground and the conductive parts of the installation are connected to ground.



MANDATORY. With an IT distribution diagram, always install the DDS system to mains through an isolating transformer.

With IT type distribution diagrams, the differential breaker is used assuming that the capacitance of mains with respect to ground is large enough to ensure that a minimum fault current flows with the same magnitude as that of the operating differential current assigned. Otherwise, its use is not necessary.



INFORMATION. Note that with an IT type distribution diagram, mains can also be controlled through an isolation watching device. Both protection measurements are compatible with each other.

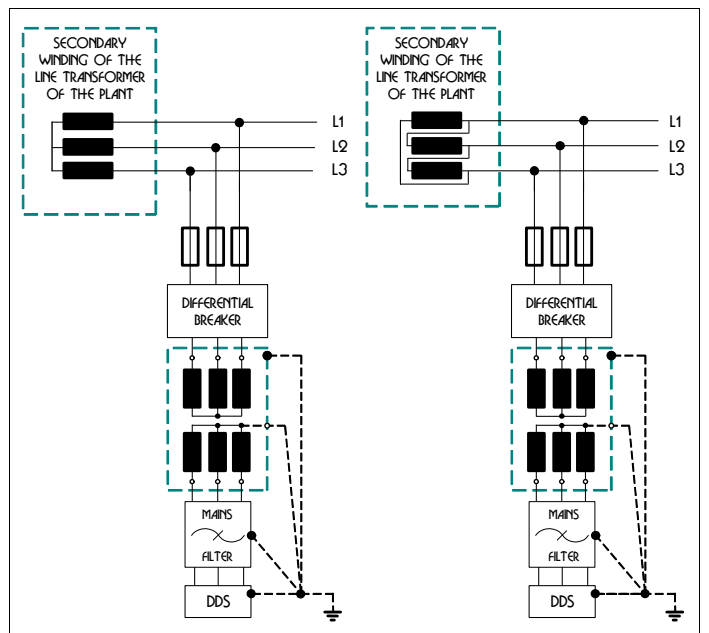

CABLE SECTIONS

SECTION	MAX. CURRENT	SECTION	MAX. CURRENT
mm ²	Arms	mm ²	Arms
0.75	8.5	6	30
1	10.1	10	40
1.5	13.1	16	54
2.5	17.4	25	70
4	23.0	35	86

Determines the maximum current in continuous duty cycle, admitted by three-phase conductors in PVC hoses and installed on the machines through conduits and channels. The ambient temperature considered is 40°C (104°F).



WARNING. Before handling the power leads: Always disconnect the three-phase voltage at the electrical cabinet. Wait, before handling these leads (about 4 min.).

GROUND CONNECTION. JOINING THE CHASSIS BETWEEN MODULES

The chassis of each module must be connected to the machine ground point. Use the washers and nuts supplied with each module to make the ground connection.

The tightening torque must be between 2.3 and 2.8 N·m. Connecting these terminals by means of metal plates offers mechanical rigidity; but it does not guarantee proper ground connection of each module.

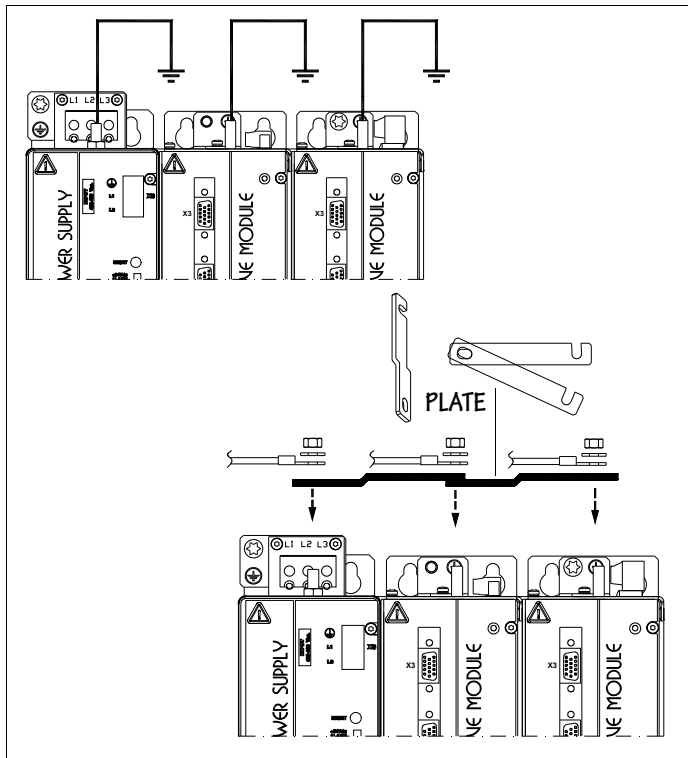

MANDATORY. Take a ground cable (as short as possible) from each module to each main machine ground point. The cable section must be the same as that of the cables connected to the largest servomotor (at least 6 mm²).

ELECTRICAL DRAWING

The schematics of the following pages are only an orientation to design the machine and may be expanded or reduced at will.

The first one shows a set of modular drives powered by a non-regenerative PS power supply.

The second one is a set of modular drives powered by a regenerative XPS power supply.

The third one illustrates the connection of a SERCOS interface.

The fourth one shows the connection of a CAN interface.

Power-up procedure

- Apply power from mains to connector X1 of the APS-24 (or to X3 of the XPS or PS-25B4). It will supply 24 V DC to each drive module drives are OK, the power supply module. Each module runs an internal test. If the test is successful, the DR.OK contacts close. If all the drives are OK, the power supply closes its "SYSTEM OK" contact.
- Push ON button. This supplies power from mains to the power supply module, "charges" the power bus with a soft start, activates the SYSTEM SPEED ENABLE of the power supply and the DRIVE ENABLE of each drive.
- Activate the control input SPEED ENABLE of each drive from the CNC. The motor can now follow the velocity command.

Emergency line

The - KA1 relay confirms that the system is mechanically and electrically in working condition.

Error reset

This circuit configuration joins the error reset and the system power-up in a single push-button.

Control from CNC

The CNC enables each axis and confirms the SPEED ENABLE signal to each drive by means of KA4, KA5, KA6 and KA7.

Stop

When the emergency line breaks or the OFF or - S1 keys are opened, the control circuit of the drives must keep on working to brake the motors, and the DRIVE ENABLE signal must be kept active (24 V DC). The FAGOR APS-24 (or the XPS, RPS or PS-25B4 auxiliary supplies) output power keep the power to the control circuits, and the DRIVE ENABLE signals are kept active while braking, by delaying the deactivation of -KA3.

BRAKE SUPPLY CIRCUIT

The brake of the FXM and FKM motors is unlocked by applying 24 V DC through a connector.

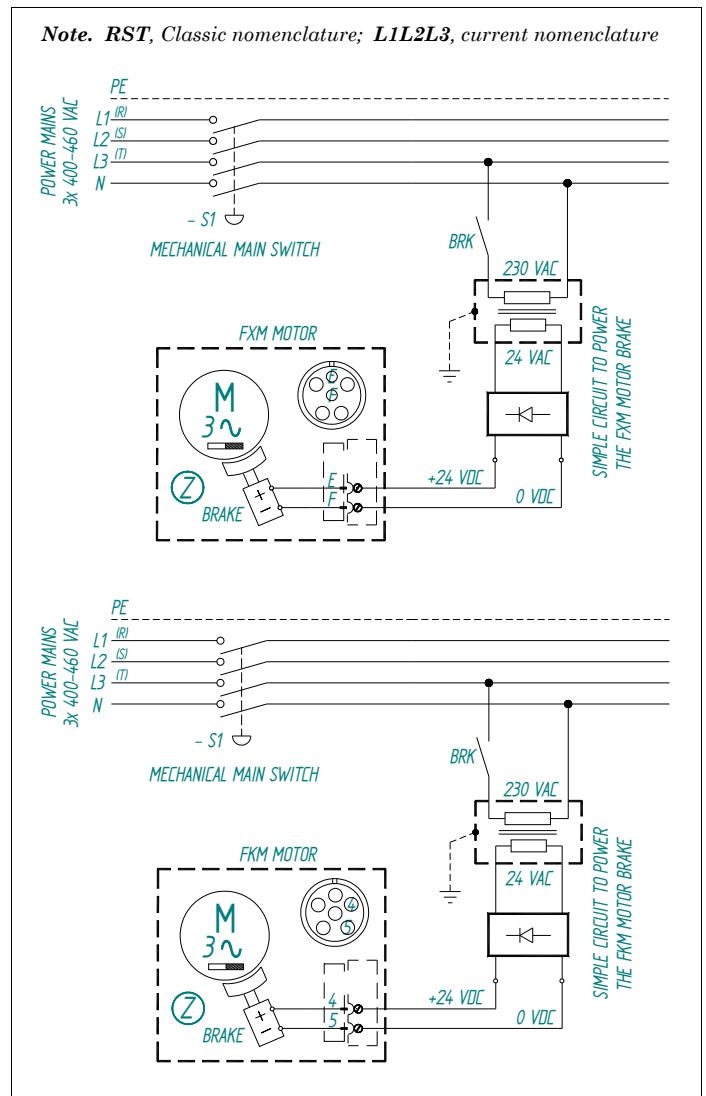

WARNING. When installing the motor, verify that the brake releases the shaft completely before turning it for the first time.

If you decide not install the mains filter and electrical choke or a transformer or an autotransformer may be installed instead. However, it does not ensure compliance with the EC Directive.

MODULAR SYSTEM WITH PS-65A

These diagrams show a set of modular drives powered by a non regenerative PS power supply.

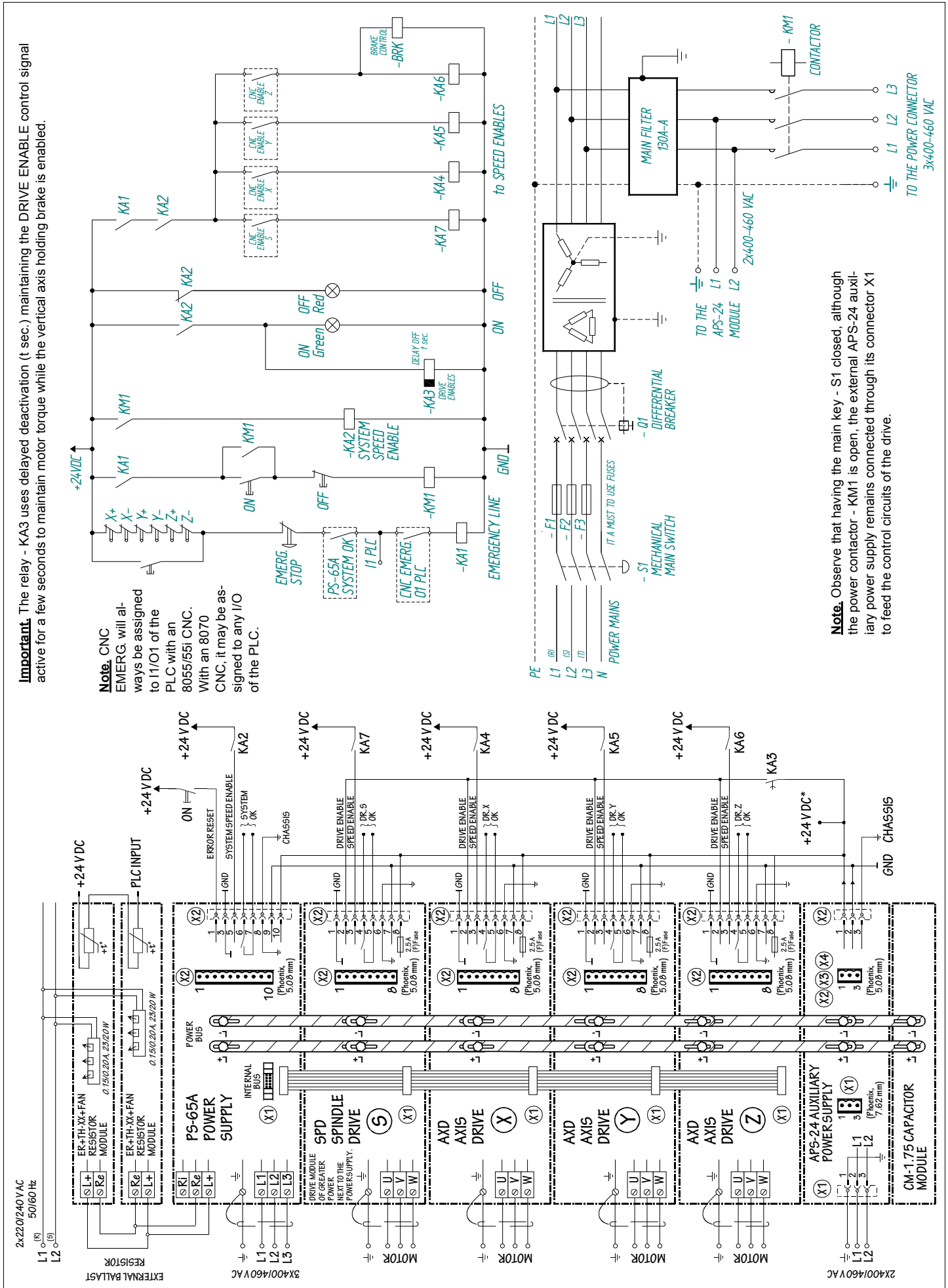

Important. The relay - KA3 uses delayed deactivation (t sec.) maintaining the DRIVE_ENABLE control signal active for a few seconds to maintain motor torque while the vertical axis holding brake is enabled.

Note. CNC EMERG. will always be assigned to I1/O1 of the PLC with an 8055/55i CNC. With an 8070 CNC, it may be assigned to any I/O of the PLC.

Note. Observe that having the main key - S1 closed, although the power contactor - KM1 is open, the external APS-2.4 auxiliary power supply remains connected through its connector X1 to feed the control circuits of the drive.

MODULAR SYSTEM WITH PS-25B4

These diagrams show a set of modular drives powered by a non regenerative PS-25B4 power supply.

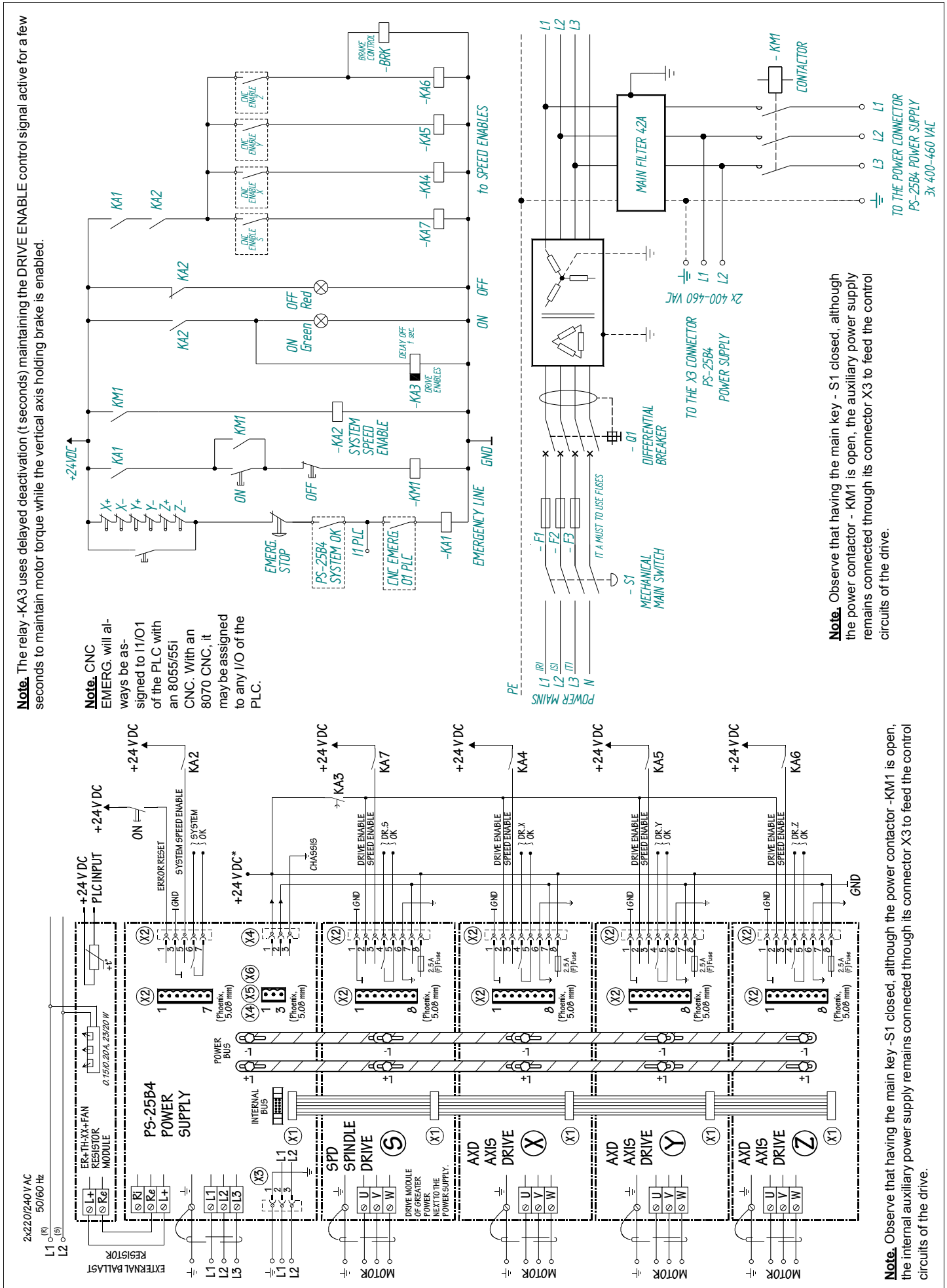

MODULAR SYSTEM WITH XPS

These diagrams show a set of modular drives powered by a regenerative XPS power supply.

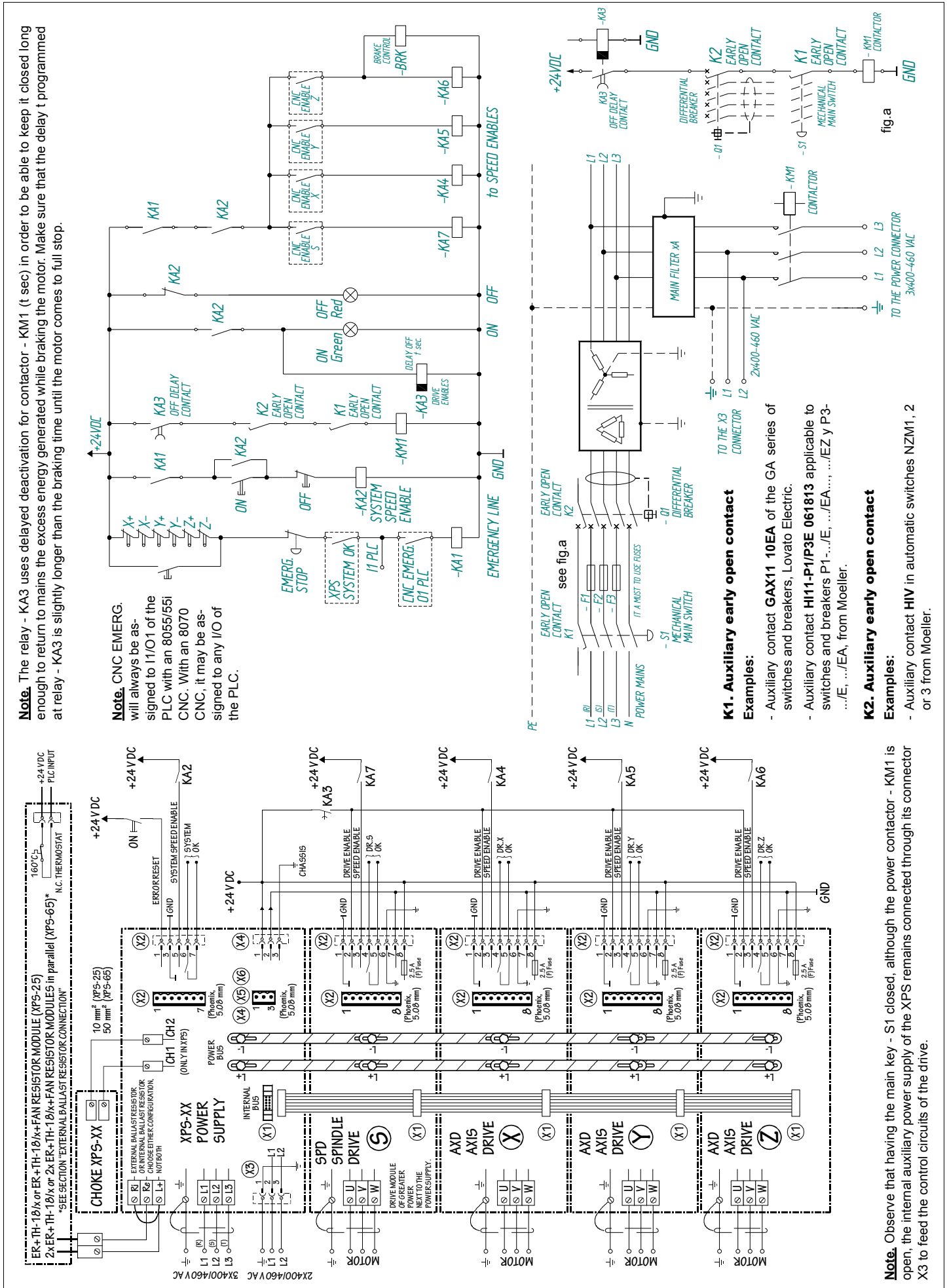

Note. The relay - KA3 uses delayed deactivation for contactor - KM1 in order to be able to keep it closed long enough to return to mains the excess energy generated while braking the motor. Make sure that the delay t programmed at relay - KA3 is slightly longer than the braking time until the motor comes to full stop.

Note. CNC EMERG. will always be assigned to I/O1 of the PLC with an 8055/551 CNC. With an 8070 CNC, it may be assigned to any I/O of the PLC.

- K1. Auxiliary early open contact**
Examples:
- Auxiliary contact GAX11 10EA of the GA series of switches and breakers, Lovato Electric.
 - Auxiliary contact H11-P1/P3E 061813 applicable to switches and breakers P1.../E, .../EA..., .../EZ y P3.../E, .../EA, from Moeller.
- K2. Auxiliary early open contact**
Examples:
- Auxiliary contact HIV in automatic switches NZM1, 2 or 3 from Moeller.

Note. Observe that having the main key - S1 closed, although the power contactor - KM1 is open, the internal auxiliary power supply of the XPS remains connected through its connector X3 to feed the control circuits of the drive.

MODULAR SYSTEM WITH RPS

These diagrams show a set of modular drives powered by a regenerative RPS power supply.

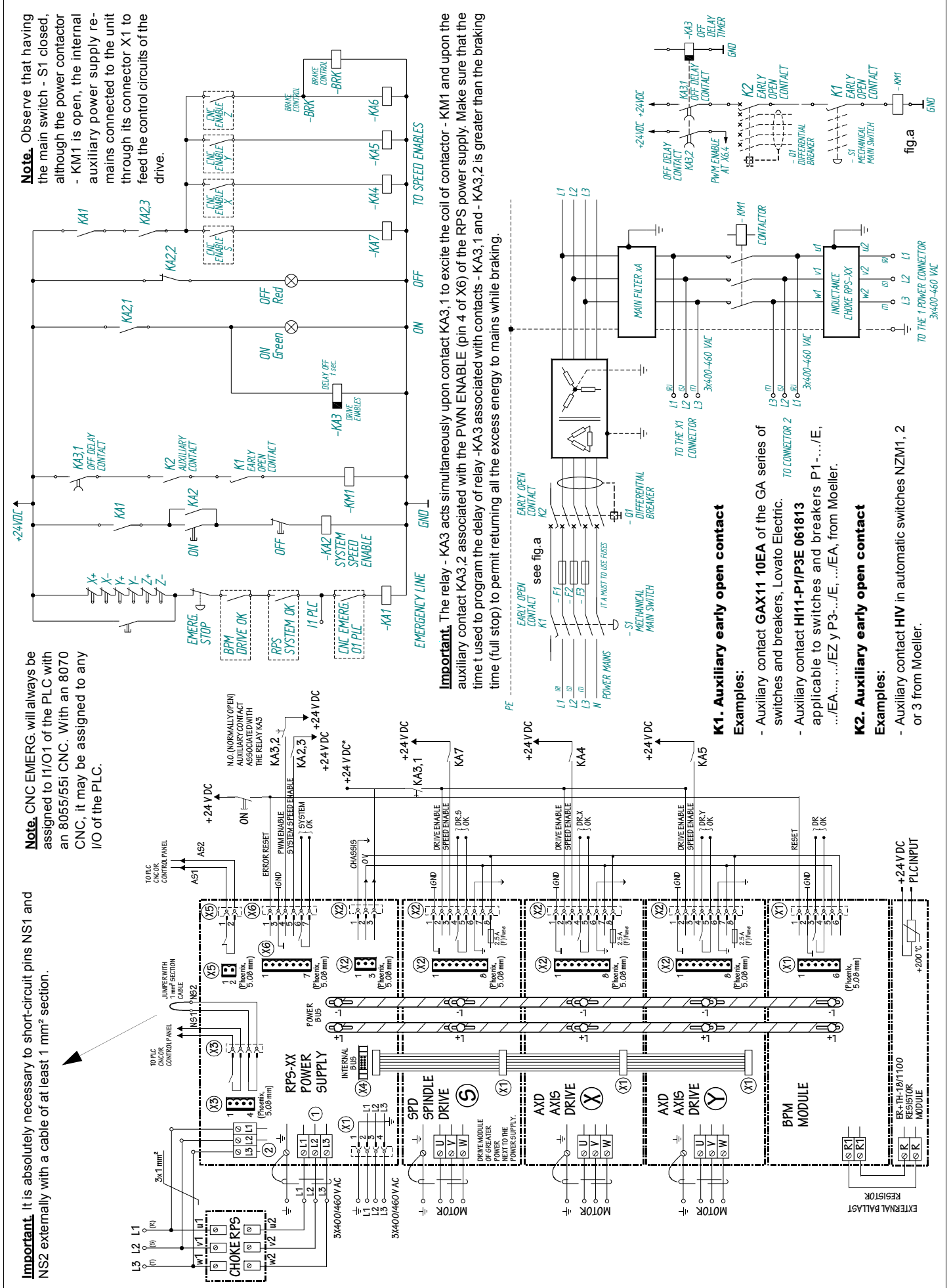

MIXED SYSTEM WITH SERCOS

The diagrams illustrate the connection of a SERCOS interface.

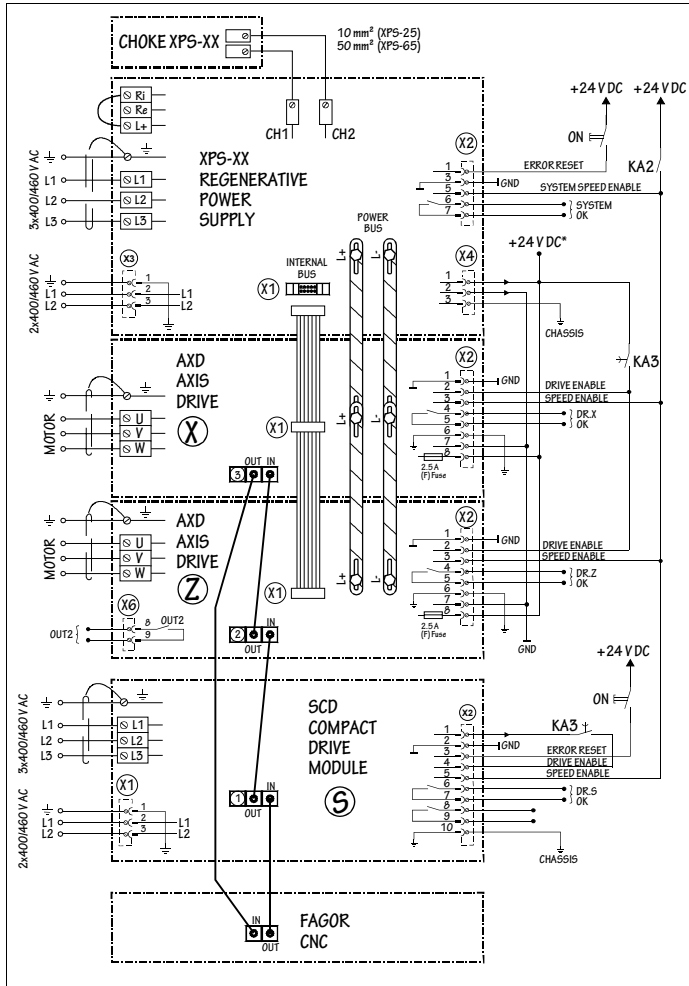

MIXED SYSTEM WITH CAN

The diagrams illustrate the connection of a CAN interface.

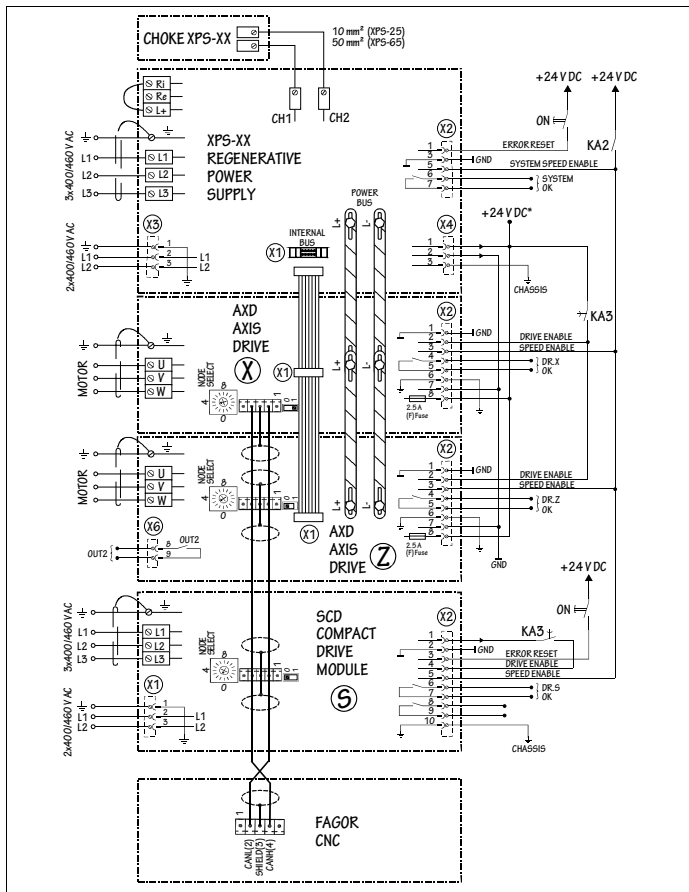

ON THE FLY STAR/DELTA CONNECTION SWITCHING ON FM7 SPINDLE, E03/HS3 SERIES

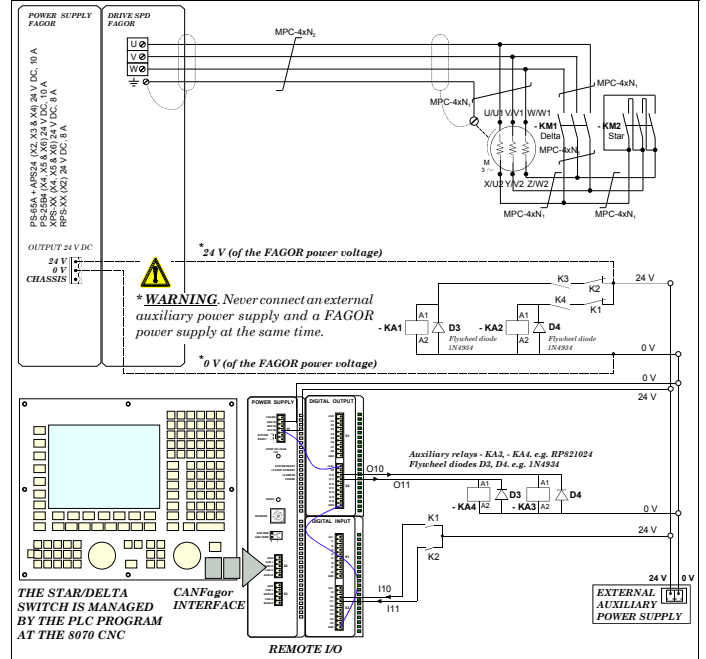

WARNING: If you decide to install an external auxiliary power supply, make sure that in case of a power outage, the 24 VDC are ensured to brake the motor under control preventing it from braking by inertia. Ignoring this warning may cause personal injury.

Notes.

The I/O selected in the figure have been chosen arbitrarily. In general any Ixx and Oxx may be used always matching the ones used in the PLC.

It is very common to choose I1 and O1 for the external emergency. Therefore, we suggest not to use them for this application. If they are going to be used, make sure that they have not been set to be used as emergency input and output.

Important warnings.

1. Either an external auxiliary power supply or a FAGOR power supply may be used to supply the 24 V DC. **NEVER CONNECT BOTH AT THE SAME TIME!**
2. To brake the motor in a controlled way during a power failure, make sure that 24 V DC will be supplied to contactors - KM1 and - KM2 and relays - KA3 and - KA4. This situation is ensured if you have installed a FAGOR power supply next to an SPD modular drive. If you have installed an external auxiliary 24 V DC power supply, you must make sure that this condition is ensured.

Sizing of -KM1 and -KM2 power contactors Sizing of motor power cables

- KM1 contactor: $I_{(KM1)} \geq I_N (\Delta)$
- KM2 contactor: $I_{(KM2)} \geq (1/\sqrt{3}) I_N (\Delta)$
- MPC-4xN₁ → N₁: section supporting I_N (Δ)
- MPC-4xN₂ → N₂: section supporting I_N (Δ)

COMPATIBILITY

MAINS VOLTAGE

Originally, the drives and power supplies were designed for a mains voltage of 380 V AC (50/60 Hz). They all have been now redesigned to work with mains voltage ranging between 400/460 VAC (50/60 Hz).

VECON-2 BOARD

This board replaces the VECON board expanding the capacity of the flash memory and increasing the operating speed of the flash memory and of the RAM memory.

VERSION OF THE VECON-2 BOARD	SOFTWARE VERSION
VEC 01A AND LATER	05.08 AND LATER 06.01 AND LATER

VECON-3 BOARD

This board replaces the VECON-2.

VERSION OF THE VECON-3 BOARD	SOFTWARE VERSION
VEC 01A AND LATER	06.18 AND LATER

VECON-4 BOARD

This board replaces the VECON-3.

VERSION OF THE VECON-4 BOARD	SOFTWARE VERSION
VEC 01A AND LATER	06.26 AND LATER 08.05 AND LATER

SERCOS BOARD (AT 16 MB)

This card will not be compatible with software versions older than 06.05 or with 07.0x or with 08.01 versions.

With software versions later than 06.04 (not included), it may be used to exchange data between the CNC and the drives that make up the SERCOS ring at 2, 4, 8 and 16 MBd.

Note. Therefore, in order to select a baudrate higher than 4 MBd, the drive must have this **SERCOS** board and any software version already mentioned.



INFORMATION. Drives having this board or older ones may be added to the **SERCOS** ring. However, all the drives must set with the same transmission speed.

CAN BOARD

Although this board was already recognized on FAGOR drives since software version 07.0x, now when using a FAGOR drive that has a CAN communication board, always install software version 08.0x.



MANDATORY. All the modules (CNC included) must set with the same transmission speed.

Note. A SERCOS board and a CAN board cannot be installed in the same drive module at the same time; i.e. the communications interface must be either SERCOS or CAN, but not both at the same time.

Note. Drive modules with software versions 07.0x and 08.0x may be installed indistinctively in the same CAN field bus.

RECOGNIZING RPS POWER SUPPLIES

From drive software version 06.09 on, it recognizes the identifier of RPS regenerative regulated power supplies and their parameters may be set.

CAPMOTOR-X BOARD

SOFTWARE	INTERFACE	MOTOR FEEDBACK BOARD
Up to 06.17	SERCOS	CAPMOTOR-1
06.18 and later	SERCOS	CAPMOTOR-1, CAPMOTOR-2
07.0x	CAN	CAPMOTOR-1, CAPMOTOR-2
08.01 to 08.04	CAN	CAPMOTOR-1, CAPMOTOR-2
08.05 and later	SERCOS/CAN	CAPMOTOR-2



INFORMATION. Remember that the **CAPMOTOR-1** board has been discontinued.

Note that a CAPMOTOR-2, as opposed to CAPMOTOR-1, can process the signals coming from a serial motor feedback with SSI protocol or En-Dat (with incremental A and B signals, necessarily). However, it cannot process signals coming from resolver feedback, which can be processed by CAPMOTOR-1.



MANDATORY. Never install a **CAPMOTOR-2** motor feedback board with a resolver as motor feedback. This combination is incompatible.

CAPMOTOR-X BOARD & THE TYPE OF FEEDBACK

FEEDBACK DEVICE TYPE	MOTOR FEEDBACK BOARD
RESOLVER	CAPMOTOR-1
STEGMANN ENCODER	CAPMOTOR-1, CAPMOTOR-2
ENCODER WITH SQUARE SIGNALS U, V & W	CAPMOTOR-1, CAPMOTOR-2
ENCODER WITH C & D SIGNALS	CAPMOTOR-1, CAPMOTOR-2
ENDAT WITH INCREMENTAL A & B SIGNALS	CAPMOTOR-2
SSI	CAPMOTOR-2

VECON-X BOARDS

SOFTWARE	INTERFACE	VECON BOARD
Up to 06.01	SERCOS	VECON
06.01 up to 06.17	SERCOS	VECON-2, VECON-3
06.18 up to 06.25	SERCOS	VECON-2, VECON-3
06.26 and later	SERCOS	VECON-2, VECON-3, VECON-4
07.0x	CAN	VECON-2, VECON-3
08.01 to 08.04	CAN	VECON-2, VECON-3
08.05 to 08.09	SERCOS/CAN	VECON-2, VECON-3, VECON-4 (vers.00A)
08.10 and later	SERCOS/CAN	VECON-2, VECON-3, VECON-4 (vers.00A and later)

POWER SUPPLIES COMPATIBLE WITH FM9 MOTORS

MOTOR REFERENCE	PS	XPS	RPS
FM9-B055-C5C□-E01-A	incompatible	incompatible	RPS-75
FM9-B071-C5C□-E01	incompatible	incompatible	RPS-80

TRANSFER OF *.MOT FILES MOTOR TABLE

Transferring any (*.mot) motor file (AKA motor table) whose version is higher than 02.01 requires having a software version 08.09 or higher installed at the drive.

Note. Drive software versions older than 08.09 are NOT compatible with motor table version 02.02 or higher.

SOFTWARE VERSION	MOTOR TABLE VERSION
Up to 08.08 included	02.01
08.09	02.02
08.10	02.03
08.11	02.04



Fagor Automation S. Coop.

Bº San Andrés, 19 - Apdo. 144
E-20500 Arrasate-Mondragón, Spain

Tel: +34 943 719 200
+34 943 039 800

Fax: +34 943 791 712

E-mail: info@fagorautomation.es
www.fagorautomation.com



Cod.14460010

